

PRODIGAL PETS

A History of Animal Sheltering in America and the Origin
of the No Kill Movement

By Susan K. Houser

Published by Susan Houser

Carrboro, NC

2018

Copyright © Susan Houser 2018, All Rights Reserved

Table of Contents

ACKNOWLEDGEMENTS	1
INTRODUCTION	3
PART I: THE FIRST ERA OF SHELTERING	7
Chapter 1: Animal Control from the Colonial Era through the 19th Century	8
Chapter 2: Philadelphia: Home of the First Animal Shelter.....	18
Chapter 3: New York City: The Politics of Sheltering.....	30
Chapter 4: Boston: A Different Approach.....	40
PART II: THE TRADITIONAL ANIMAL SHELTER	46
Chapter 5: Shelter Operations in the 20 th Century	47
Chapter 6: Death at the Shelter.....	58
Chapter 7: Pound Seizure	64
PART III: SHELTERS AND PET POPULATION	76
Chapter 8: The Pet Overpopulation Crisis.....	77
Chapter 9: A Simple Surgery.....	85
Chapter 10: Reducing Shelter Intake	94
PART IV: THE NO KILL IDEA	106
Chapter 11: Evolving Attitudes Toward Homeless Pets.....	107
Chapter 12: Early No-Kill Sheltering.....	114
Chapter 13: Using Marketing to Save Lives	122
Chapter 14: Feral Cats and the Origin of TNR.....	132
PART V: NO KILL CITIES	145
Chapter 15: San Francisco: No Kill Programs.....	146
Chapter 16: San Francisco: No Kill Model	155
Chapter 17: Parallel No Kill Efforts.....	164
PART VI: THE NO KILL MOVEMENT	170
Chapter 18: The Human Toll of the Traditional Shelter.....	171
Chapter 19: In the Name of Mercy	178
Chapter 20: Organizing the Grassroots.....	185
EPILOGUE: NO KILL IN THE 21ST CENTURY	198

Acknowledgements

Acknowledgements

I want to express my gratitude and thanks to the people who helped me with this book. The help was offered in many different forms, including interviews, advice, and providing historical documents. Almost everyone I contacted about the book was willing to help, and some spent hours answering my questions or proofreading or finding and sending me materials.

The book could not have been written without the assistance of Bonney Brown. She encouraged me, answered endless questions, introduced me to interviewees, and sent me boxes of rare documents that proved invaluable. Richard Avanzino spoke with me over the course of several interviews about the development of the first No Kill city. Historian Bernard Unti helped educate me about the crucial period from the Civil War to the 1920s, recommended materials, and reviewed the manuscript. Andrew Rowan answered all my many questions about dog and cat statistics, the spay-neuter movement, the Pound Seizure issue, and the use of animals in laboratories. Merritt Clifton, who has studied and written about animal sheltering for decades, was very generous with his knowledge and sent me a lot of helpful material. Ed Duvin communicated with me at length about the philosophy of No Kill and the milieu in which it developed.

Many other people provided help that was crucial on some of the individual topics in the book. Ellen Perry Berkeley, Becky Robinson, Julie Levy, and other Trap-Neuter-Return practitioners and pioneers enlightened me on the history of efforts to manage and assist community cats. Several people provided information on notable early metro and statewide shelter-reform efforts, including Bob Rohde (Denver) and Peter Marsh and Bert Troughton (New Hampshire). I'm grateful to the American Pet Products Association, which provided me with data on trends in pet markets.

I'm indebted to the people at Bideawee and the Women's Humane Society who sent me copies of important historical documents. Esther Mechler gave me a detailed look at the spay-neuter campaigns of the 1990s. Mike Arms provided an in-depth look at his game-changing work on adoption marketing. Steve Zawistowski's encyclopedic knowledge of sheltering was helpful to me in developing the big-picture outline of the book, and I appreciated his comments on the text. Jan McHugh-Smith talked to me about the earliest years of the Open Adoption movement in the 1990s.

Doug Fakkema gave me a vivid picture of what it was like to work at high-volume shelters in the 1970s and 1980s, as well as the toll that such work took on shelter workers. Lynn Spivak, Mary Ippoliti-Smith, and Sharon Fletcher aided my research on the San Francisco SPCA in the crucial years from 1976 to 1999. Lynda Foro (who passed away in late 2016) told me how her groundbreaking work of the 1990s unfolded. Betsy Banks Saul recounted the early days of Petfinder. Craig Brestrup described his own case study of No Kill reform. Several people from Best Friends Animal Society, including Michael Mountain, Faith Maloney, Francis Battista, and Gregory Castle, described the history of Best Friends and its crucial role in the development of the early No Kill movement. On the technical side, Don Jennings managed the transition and layout of the book from Word to PDF and did a wonderful job creating a new Out the Front Door website that presented the book in searchable chapters.

Many more people contributed interviews, documentation, and advice than I have space to mention here. I'm grateful to all of you.

Introduction

Animal shelters can be found in most jurisdictions in the United States, yet the history of animal sheltering has received little attention. This book seeks to fill that gap.

Sheltering can be divided into three eras—early, traditional, and No Kill. The “early” era lasted from colonial days to around 1920, encompassing the development of animal sheltering from dog control to a public-private system that included attention to animal welfare. The second era lasted from roughly 1920 to 2000 and saw the institutionalization of animal sheltering and the origin of the No Kill movement. The third era—No Kill—began around the year 2000. This book covers the early and traditional eras of sheltering, with an emphasis on the origin of No Kill in the years from 1970 to 2000.

The modern animal shelter is a surprisingly complex institution. It may be public or private, or a mixture of the two. It may operate on its own or be part of a coalition of organizations. Its funding may come entirely from government or entirely from the private sector, or anywhere in between. The labor to carry out sheltering may be paid, volunteer, or a mixture. Some shelters take in any animal that comes to the door, including animals surrendered by their owners, while others restrict the number or type of animals they admit.

Public animal shelters (shelters run by city, town, or county governments) have two distinct operational aspects—animal control and animal care. Animal control is the public function. The core mission of animal control is to protect people from animals, and it requires the police powers of the state to carry out. The animal care aspect of public shelters has gained increasing attention in recent decades, and today it may include a goal of releasing as many animals as possible alive. At a minimum, it means humane treatment of animals while in the shelter. Many public shelters have changed their names in recent years to some version of “Animal Care and Control” to reflect these twin missions.

Part I of this book covers the first era in animal sheltering, from colonial times to about 1920. The earliest animal control measures in the United States date back to the 1600s and were primarily designed to allow individuals to protect their livestock from free-roaming dogs. In the late 1700s and early 1800s, state and local governments began to become more involved in animal control due to the increasing threat of rabies from dog bites. There was no vaccine available for rabies until near the end of the 1800s, and panics induced by fear of the disease were frequent in cities in the 19th century.

The increasing need for animal control spurred the development of city “pound” systems staffed by dog catchers. Dog pounds in the 19th century were often cruel. In Philadelphia; for example, dog catchers killed unclaimed dogs by beating them to death. Caroline Earle White, one of the three great leaders of the post-Civil War animal protection movement, was appalled by this cruelty. She negotiated a contract with the city of Philadelphia for her organization, the Women’s Branch of the Pennsylvania SPCA, to take over the dog pound. In 1870, the Women’s Branch built a new, humane facility and called it a “shelter” to distinguish it from the pound. In 1874, the Women’s Branch opened a second shelter, the City Refuge, which accepted all types of animals and had no government connection. Both of the Women’s Branch facilities were the first of their kind, and both became models that were replicated by animal welfare organizations in many other cities.

The phenomenon of private humane organizations taking over governmental duties of animal control by contract, and supplementing animal care expenses with donated funds, was an early example of a public-private partnership. The three centers of the animal protection movement in the late 1800s—Philadelphia, New York City, and Boston—all had some form of public-private arrangement for either dog care and control, cat care and control, or both by 1910. These public-private partnerships were notable in that the private sector involvement was motivated not by profit, but by compassion.

The “traditional” era of animal sheltering is discussed in Part II. This era extended from roughly 1920 to 2000, but from 1970 to 2000 it overlapped with the origin of the third era, No Kill. The years from 1920 to 1950 were a time of institutionalization of animal care and control. Animal shelters were not a priority for governments, and the demands of animal care weighed down the private humane organizations that were involved in sheltering. The animal protection movement stagnated in the years from 1920 to 1950 as large numbers of humane organizations dedicated much of their resources to the never-ending task of animal sheltering. The best shelters provided humane care for their animals, but many shelters, both public and private, used inhumane practices such as pumping hot, unfiltered vehicle exhaust into a closed room for “euthanasia.” Shelters in this era killed the great majority of animals taken in.

Two shelter-related controversies erupted in the 1950s and played a central role in re-energizing the animal protection movement. One was a controversy over a cruel method of shelter killing called “decompression.” The other was a battle over researchers seizing dogs and cats from shelters to use in painful laboratory experiments. These controversies led to the formation of important new animal-protection organizations, including the Humane Society of the United States and the Animal Welfare Institute.

Parts III through VI of the book discuss four distinct historical developments in the years from 1970 to 2000 that contributed to the emergence of a viable model of No Kill sheltering by the year 2000. Those developments were the battle to control pet overpopulation (Part III), the creation of individual private No Kill shelters (Part IV), the creation of entire No Kill communities (Part V), and the growth of a grassroots movement to promote No Kill sheltering (Part VI). In addition to those shelter-centric developments, Parts III to VI also take note of developments in society during the years from 1970 to 2000 that affected sheltering, including the animal rights movement and changes in public attitudes toward animals.

The pet overpopulation crisis became a hot topic in the media in the early 1970s due to nuisances and public health issues created by free roaming cats and dogs, who were plentiful in the streets back then. A majority of dogs and cats in most communities were unsterilized in those days, and it was common to allow them to roam freely, leading to large numbers of puppies and kittens. Public health officials raised the alarm about dangers of disease transmission. Citizen complaints about nuisance animals outnumbered all other types of complaints to city officials. The number of animals impounded each year in the early 1970s far outpaced the available homes for them, resulting in the killing of roughly 20 million cats and dogs in shelters each year.

Fortunately, by 1970, the veterinary profession had perfected surgical techniques that made sterilization procedures safe and feasible for veterinarians in private practice. Low cost spay-neuter clinics began to appear around 1970, which motivated private veterinarians to begin to offer sterilization of pets as an option. Humane organizations and concerned individuals, including many from the traditional shelter industry, advocated for spay-neuter and for keeping pets at home. In the 1990s, pediatric spay-neuter became an accepted procedure, options for low cost spay-neuter were expanded, and private veterinarians began to actively promote spay-neuter as a routine part of pet healthcare.

These measures correlated with a spectacular fall in shelter intake from 1970 to 2000. We do not have comprehensive national statistics for animal shelters during that time, but the estimates we have indicate that shelter intake fell very sharply between 1970 and 2000 in absolute numbers. This trend is even more impressive if considered relative to the growth in human population and the number of owned pets during that time. The plunge in shelter intake that happened from 1970 to 2000 made the No Kill movement possible, because it brought the number of shelter animals into much closer balance with the number of people who acquire pets. For the first time it began to seem possible that homes could be found for shelter animals without simply displacing other homeless dogs and cats.

The “No Kill” term did not come into common use in animal sheltering until the 1970s, but there have been occasional individual private shelters that eschewed killing since the late 1800s. These private shelters, discussed in Part IV, had no responsibility to do animal control or take in free roaming animals and owner surrenders. They had the ability to limit the number of animals they took in to the number they could house permanently or place by adoption. Free of the burden of dealing with overwhelming numbers of animals, these shelters could experiment with techniques for engaging the public and placing more animals through adoption. Another lifesaving approach that began to take hold in the 1970s was Trap-Neuter-Return (TNR) for feral cats.

The plunge in shelter intake and the growth of private No Kill shelters and TNR in the 1970s and 1980s set the stage for taking No Kill to the next level, which was creating entire No Kill communities. Before that could occur, operational techniques had to be developed that could deal with the volume and type of animals who came into city and county shelters. Part V discusses how this task was accomplished in San Francisco, the Denver metro area, the state of New Hampshire, and several small towns and counties in the period from 1970 to 2000. By the late 1990s, those locales were reporting save rates of 70% to 90%, much better than the average community save rate at that time of perhaps 25% to 35%.

The San Francisco model, developed in the years from 1976 to 1998 by Richard Avanzino, the president of the San Francisco SPCA, has been particularly influential. The core of the San Francisco model is a public-private partnership between a municipal shelter and a non-profit shelter. The non-profit shelter is dedicated first and foremost to taking at-risk animals from the municipal shelter, treating and rehabilitating them as necessary, and finding new homes for them. The model that evolved in the Denver metro area was similar in the level of cooperation but less centralized, involving a large coalition of area shelters. New Hampshire’s route to No Kill was a combination of a state-supported low income spay-neuter program and individual progressive shelters that were members of a state federation.

Spurred by increasing evidence that it was possible for entire communities to save a high percentage of their shelter animals, a grassroots movement to spread the word about No Kill came into being in the 1990s, as discussed in Part VI. The beginning of this grassroots movement is often dated to 1989 because of two key events that happened in that year. The first event was the San Francisco SPCA giving up its contract with the city to do animal control and sheltering, which ultimately resulted in its successful public-private partnership with a newly founded city shelter. The second was the publication of an essay called *In the Name of Mercy* by animal rights activist, Ed Duvin. Duvin’s essay analyzed the moral failings of the traditional shelter system and offered a vision of a new ethic of sheltering. The momentum created by Duvin’s work was captured by No Kill activist Lynda Foro, who started a series of highly influential No Kill conferences in 1995.

By the year 2000, No Kill was an established force in animal sheltering, with an operating philosophy, proven models, and grassroots supporters to carry the message. Also by the year 2000, the number of cats and dogs in the United States who were taken into shelters each year had declined to the point where it was at least theoretically possible to find homes for all of them. For these reasons, the year 2000 can be seen as the beginning of the No Kill era of animal sheltering, although the number of No Kill communities at that time was still small.

A full account of the revolutionary changes in animal sheltering since 2000 would require its own book, but the Epilogue takes a brief look at some of the high points. As this Introduction is written in 2018, it seems probable that within a very few years shelters in the United States will be saving all their healthy and treatable animals. Indeed, the very nature of the animal shelter is changing, as shelters transition from a reactive mode of dealing with surrendered and stray animals to an active mode of providing a community-wide safety net for all pets.

Part I: The First Era of Sheltering

Chapter 1: Animal Control from the Colonial Era through the 19th Century

Today's animal shelters have two core functions, animal care and animal control. The earliest of those functions was animal control, or more specifically, dog control. In colonial times, dogs chased and killed livestock, spooked horses, and bit people. Cities reacted by establishing dog control measures to protect people and livestock from threats posed by dogs. By contrast, cats appear to have drawn little attention to themselves until the late 1800s, other than their early association with witchcraft.¹



JANUARY.

Printed and published by the author, at the office of the printer, No. 1, Nassau Street, New York.

Figure 1:

Animals were part of daily life in Europe and the United States, as illustrated in this circa 1820 skating scene, which includes sheep, cattle, dogs and birds. Author unknown, public domain.

Livestock killing was a very serious offense in early colonial times, since the settlers were dependent on their livestock for food and clothing.² In the colony of New York, which was established in 1609, wolves and dogs killed so many sheep that by the mid-1600s only a few survived.³ The town of Salem, Massachusetts passed a 1635 ordinance requiring dogs to be “tyed up in the day tyme” and “sent away or killed” if they were a nuisance.⁴ The Massachusetts colony passed a law in 1648 providing that any dog who killed a sheep was to be killed by hanging unless its owner paid double the value of the sheep.⁵

As cities grew, so did the number of dogs roaming the streets. The city of Williamsburg in Virginia passed a law in 1772 aimed at “fierce Dogs” who were running the city streets “in too great Numbers” and biting and annoying people.⁶ The law allowed anyone to kill a dog that was out without a collar in the daytime, and dogs who were out at night could be killed even if they had a collar.

¹ James Serpell, “Domestication and History of the Cat,” chap. 7 in *The Domestic Cat: The Biology of Its Behavior*, 3rd ed., ed. Dennis Turner and Patrick Bateson (Cambridge: Cambridge University Press, 2014), 94–98; John Bradshaw, *Cat Sense* (New York: Basic Books, 2013), 58.

² J. Fred Smithcors, *The American Veterinary Profession: Its Background and Development* (Ames: Iowa State University Press, 1963), 13–14.

³ *Ibid.*

⁴ *Ibid.*, 20.

⁵ *The Colonial Laws of Massachusetts: Reprinted from the Edition of 1672*, ed. William Whitmore (Boston, 1887), 138; Smithcors, *American Veterinary Profession*, 13.

⁶ “An Act to Prevent Mischief from Dogs,” Common Hall, Williamsburg, Virginia, Sept. 7, 1772.

Part I: The First Era of Sheltering
Chapter 1: Animal Control from the Colonial Era through the 19th Century

The horse was the primary means of moving goods and people within cities until the early 20th century,⁷ and dogs who chased or spooked horses were a special hazard. When horses who were pulling a carriage or wagon got out of control and ran wildly, it could be fatal to the occupants of the vehicle and anyone in their path.⁸ Horses can weigh half a ton or more, and a runaway horse could produce pandemonium in city streets, with people and other horses scrambling to get out of the way. In one case in 1861, a man named Jesse Thornley was riding in his wagon, pulled by a “spirited” horse, when a dog leaped at the horse’s head. Thornley struck at the dog and further frightened the horse, which bolted. Thornley was thrown out of the wagon and under its wheels, dying from the injuries he sustained.⁹



Figure 2:
An 1841 illustration from Punch showed what could happen when a dog spooked a horse.
Public domain.

Dogs were popular in spite of the problems they caused. To some extent, this was practical, as many dogs had jobs. The upper class had hunting dogs, and dogs were used by working class people as guards, sheep herders, turnspits, cart pullers, and ratters.¹⁰ Dogs were also kept as pets.

Susan Pearson, in her book *The Rights of the Defenseless*, describes the effect of industrialization on the place of pets in families. Industrialization changed families from an economic unit where women, children, and animals all worked, to the center of emotional life where pets were kept because of the owner’s attachment.¹¹

In the late 1700s and early 1800s, a new threat to the human-dog bond—rabies—appeared. Fear of rabies would deeply affect the attitudes of people in the United States toward homeless dogs throughout the 19th century.¹² The fear was exacerbated by the fact that little was known about the disease.¹³ It was not known whether the causative agent was the same in dogs as in people, and the disease therefore went by two

⁷ Katherine Grier, *Pets in America: A History* (Chapel Hill: University of North Carolina Press, 2006), 187–188.

⁸ Eric Morris, “From Horse Power to Horsepower,” *U.C. Transportation Center ACCESS Magazine*, Spring 2007, 6, accessed March 31, 2017, <http://www.uctc.net/access/30/Access%2030%20-%202002%20-%20Horse%20Power.pdf>.

⁹ “Sad Accident,” *Philadelphia Inquirer*, July 15, 1861.

¹⁰ Grier, *Pets in America*, 26–28; Asa Greene, *A Glance At New York: Embracing the City Government, Theatres, Hotels, Churches, Mobs, Monopolies, Learned Professions, Newspapers, Rogues, Dandies, Fires and Firemen, Water and Other Liquids, &c., &c.* (New York, 1837), 90–91; Alvin Harlow, Henry Bergh: Founder of the A.S.P.C.A. (New York: Julian Messner, 1957), 119–120.

¹¹ Susan Pearson, *The Rights of the Defenseless: Protecting Animals and Children in Gilded Age America* (Chicago: University of Chicago Press, 2011), 32–33. Although changes in the family brought about by industrialization may have helped make affection for pets a societal norm, archeologists have found indications that some individuals regarded dogs and cats with affection virtually since they began to live with people. David Grimm, *Citizen Canine: Our Evolving Relationship with Cats and Dogs* (New York: Public Affairs, 2014), 30, 35.

¹² Grier, *Pets in America*, 214; Harriet Ritvo, “Animals in Nineteenth-Century Britain: Complicated Attitudes and Competing Categories,” chap. 6 in *Animals and Human Society: Changing Perspectives*, ed. Aubrey Manning and James Serpell (1994; repr., New York: Routledge, 2011), 110–111; Bill Wasik and Monica Murphy, *Rabid: A Cultural History of the World’s Most Diabolical Virus* (2012; repr., New York: Penguin, 2013), 94.

¹³ Philip Teigen, “Legislating Fear and the Public Health in Gilded Age Massachusetts,” *Journal of the History of Medicine and Allied Sciences* 62, no. 2 (April 2007): 147–148, doi:10.1093/jhmas/jrl016. Incorrect theories of the cause of rabies included spontaneous generation and a “worm under the tongue,” referring to a normal fibrous structure at the end of a dog’s tongue. Smithcors, *American Veterinary Profession*, 92, 126–127.

Part I: The First Era of Sheltering
Chapter 1: Animal Control from the Colonial Era through the 19th Century

different names—"rabies" for the disease in dogs and "hydrophobia" for the disease in people.¹⁴ Today we use the term "rabies" for the disease in both animals and people.

Rabies is caused by a virus, and once symptoms develop, it is almost always fatal.¹⁵ The disease can be transmitted by any mammal,¹⁶ but people in 19th century America believed that rabies was primarily transmitted by dogs, particularly homeless or mixed breed dogs.¹⁷ An 1856 report prepared for the American Medical Association described many cases of rabies in people in detail, and it was an agonizing death.¹⁸ The report singled out dogs as the major vector of the disease.



Figure 3:
Dog with muzzle, circa 1870. "Rabies and hydrophobia... George Fleming 1872," by Wellcome Images, licensed under CC-BY 4.0.

Rabies presents in two different forms, one with spasms and difficulty in drinking, and one with an ascending paralysis.¹⁹ These two forms are sometimes called "furious" and "dumb" rabies, respectively.²⁰ The incubation period for the disease is highly variable, and it may be anywhere from a few weeks to a few months from the date of a bite until symptoms occur.²¹ This variability in the incubation period and in how rabies presented meant that doctors in the 1800s had difficulty in accurately diagnosing the disease. Fear of rabies was increased by media reports. A newspaper article in 1861 described how a four-year-old boy was attacked by a dog and bitten in the face, and the dog then bit the father who intervened to protect his son.²² The dog was thought to be rabid, and one can only imagine how the family must have felt waiting to see if two of its members would develop the fatal disease. In a case that probably was

rabies, a man who was bitten on the hand by a free roaming dog developed pains in his arms two months later which turned into tremors and then convulsions.²³ He had spasms at the sight of water and died four days after he began to have symptoms.

In other cases that were reported in the media, it seems unlikely that rabies was the real culprit. For example, a news report in 1861 attributed the illness of a young woman with seizures to her contact with a dog who, two years previously, had chased her and torn her clothes but not bitten her.²⁴ A lengthy

¹⁴ Teigen, "Legislating Fear," 148.

¹⁵ A study published in 2012 indicated that some people in the Peruvian Amazon survived rabies infections from bats. Amy Gilbert, et al., "Evidence of Rabies Virus Exposure Among Humans in the Peruvian Amazon," *American Journal of Tropical Medicine and Hygiene* 87, no. 2 (August 2012): 211, doi:10.4269/ajtmh.2012.11-0689. Other sporadic cases of survival after rabies infection have been reported. Rodney Willoughby, Jr., "Resistance to Rabies," editorial, *American Journal of Tropical Medicine and Hygiene* 87, no. 2 (August 2012): 205, doi:10.4269/ajtmh.2012.12-0304.

¹⁶ "What Kind of Animal Did You Come in Contact With?," *Centers for Disease Control and Prevention*, last modified April 22, 2011, <http://www.cdc.gov/rabies/exposure/animals/index.html>.

¹⁷ Wasik and Murphy, *Rabid*, 31; "Learn the New Dog Law," *Philadelphia Inquirer*, June 8, 1907.

¹⁸ Thomas Blatchford, *Hydrophobia: Its Origin and Development, As Influenced by Climate, Season, and Other Circumstances* (Philadelphia, 1856).

¹⁹ J. M. S. Pearce, "Louis Pasteur and Rabies: A Brief Note," *Journal of Neurology, Neurosurgery, and Psychiatry* 73, no. 1 (August 2002): 82, doi:10.1136/jnnp.73.1.82.

²⁰ "Rabies: Symptoms," *World Health Organization*, accessed March 31, 2017, http://www.who.int/rabies/home_symptoms/en/.

²¹ "The Path of the Virus," *Centers for Disease Control and Prevention*, last modified April 22, 2011, <http://www.cdc.gov/rabies/transmission/body.html>.

²² "Bitten by a Mad Dog," *Philadelphia Inquirer*, September 21, 1861.

²³ "Death from Hydrophobia," *Philadelphia Inquirer*, November 14, 1861.

²⁴ "Distressing Case of Hydrophobia," *Philadelphia Inquirer*, March 20, 1861.

Part I: The First Era of Sheltering
Chapter 1: Animal Control from the Colonial Era through the 19th Century

newspaper description of an unlucky man's illness and death in 1875 certainly made the case sound like rabies—except that the dog in question, who had nicked the victim with a tooth (by accident, in play), was still alive and healthy.²⁵ One can understand how a person reading frequent accounts like these would be not only confused about the nature of the disease, but also convinced that the likelihood of getting rabies from a dog was far greater than it actually was.

The odds of a person getting rabies in the 1800s were quite low compared to other serious diseases, even during rabies outbreaks. During an outbreak of rabies from 1876 to 1881 in Massachusetts, for example, 44 people died of rabies, while 11,215 people died of cholera and 12,387 died of diphtheria during that same time period.²⁶ The rarity of human deaths from rabies caused some people, including some doctors and veterinarians, to believe that the disease was merely hysteria and that the only people who died from it were people who allowed themselves to be frightened to death following a bite from a dog.²⁷ A Boston veterinarian who served as the city's dog catcher insisted in 1888 that the disease did not exist, citing the fact that he had been frequently bitten over his career without contracting it.²⁸ As late as 1896, the American Anti-Vivisection Society released a letter stating that rabies was merely a collection of symptoms brought on by fear.²⁹ Several "prominent physicians" were quoted in the letter, and it was said that the Philadelphia dog shelter had not had a case of rabies in any of its employees in 25 years of operation.

By the latter decades of the 19th century, it was known that other animals besides dogs and humans could be affected by rabies.³⁰ The public still believed though that the best means of avoiding rabies was controlling stray and homeless dogs.³¹ This was in line with society's general disapproval of mixed breed dogs.³² Purebred dogs had more value and snob appeal than mixed breed dogs, but the dislike for mixed breeds went beyond that. There was a common belief that mixed breed dogs had inherently bad characters that rendered them useless to society. Mixed breed dogs were called "curs," "mongrels," or "yellow dogs," and none of those terms was complimentary. A reporter in New York expressed a typical sentiment when he referred to dogs at the city pound as "a set of worthless curs."³³ An 1858 book for young people advised that mixed breed dogs were "certain to be cowardly and thievish, and likely to be treacherous, noisy, and unruly."³⁴ On the other hand, according to the author: "Almost all pure-bred dogs are good."

Attitudes toward dogs sometimes reflected class stratifications, and working-class people and immigrants did not necessarily share the disdain that the upper classes had for mixed breed dogs.³⁵ A reporter in Boston, writing about working class neighborhoods in 1895, said: "It is often remarkable what an affection people will show for the poorest kind of curs."³⁶

²⁵ "Death from Hydrophobia," *Boston Post*, June 22, 1875.

²⁶ Teigen, "Legislating Fear," 145, table 1.

²⁷ *Ibid.*, 156–160. As late as 1906, even after the cause of rabies was known, a society column in the *New York Times* cited "experienced dog catchers" for the proposition that rabies was "produced by the imagination and is not a real disease." "Some Curious Specialties," *New York Times*, July 8, 1906.

²⁸ W.A. Parcellle, "Like an Avenging Angel," *Boston Daily Globe*, July 2, 1888.

²⁹ "Don't Get Excited: Persons Cautioned to Keep Cool When Bitten by Animals," *Philadelphia Inquirer*, June 27, 1896.

³⁰ Teigen, "Legislating Fear," 146n7.

³¹ In 1877 the Massachusetts Board of Health opined that dogs who lived in unnatural conditions, whether as starved strays or as overly pampered lapdogs, were more likely to develop rabies. Teigen, "Legislating Fear," 160.

³² Grier, *Pets in America*, 27–34.

³³ "An Hour at the Dog Pound," *New York Times*, August 5, 1856.

³⁴ *The Book of One Thousand Tales and Amusing Adventures: A Work for Youth* (New York, 1858), 431.

³⁵ Teigen, "Legislating Fear," 166.

³⁶ "The Dog Scoop," *Boston Post*, August 15, 1895.

Part I: The First Era of Sheltering
Chapter 1: Animal Control from the Colonial Era through the 19th Century

Although legal restrictions on free roaming dogs date back to the 1600s, the means of enforcing the restrictions changed radically beginning around 1800. Before 1800, dealing with nuisance or aggressive dogs was generally a matter of self-help, as dog control laws specified citizen enforcement rather than enforcement by state or local officials. That was in keeping with the custom of the time that maintenance of the health and safety of a community was the responsibility of its individual citizens rather than the government.³⁷ The danger of rabies helped spur city leaders in the 19th century to move away from this tradition of self-help and begin to assign the responsibility for controlling free roaming dogs to government officials and deputized citizens. State legislatures also began to enact animal control measures as part of their police powers to protect citizens.³⁸

In 1798, one of the earliest anti-rabies provisions went into effect in Massachusetts, requiring dogs to wear collars and their owners to pay a tax.³⁹ Philadelphia adopted a dog ordinance in 1811 that referred to the danger of “canine madness” and provided that any dog at large after May 10th without a collar and identification tag should be seized and killed by the police or other persons appointed by the mayor.⁴⁰ In 1825, the Massachusetts state legislature passed a law allowing local ordinances to require not only registration in the form of licensing but also “restraining of Dogs going at large.”⁴¹ Dog control ordinances were frequently modified as the fear of rabies waxed and waned, but they generally targeted dogs running at large and had provisions for registration, licensing, identification, leashing, or muzzling.⁴²

Even small towns enacted dog ordinances in the early and mid-1800s. The town of Allegany, Pennsylvania enacted an 1831 dog control ordinance following a rabies scare.⁴³ Madison, Indiana, which had a population of about 8,000 people in the 1850 census, enacted an ordinance in 1848 providing that any person could kill a dog running at large by itself without a collar, and that the mayor could order the confining or muzzling of all dogs in the city during times when rabies was a danger.⁴⁴

License fees were sometimes quite high relative to the value of a dog.⁴⁵ This made the metal licenses that were attached to a dog’s collar subject to theft, since the expense of the license created an incentive for people to steal one rather than buy their own.⁴⁶ The purpose of license fees in many cases was clearly not just to identify dogs, but to reduce dog populations, either by the size of the fee or by charging more to license females. The license fee in Boston in the late 1800s was \$2.00 for a male dog and \$5.00 for a

³⁷ Jessica Wang, “Dogs and the Making of the American State: Voluntary Association, State Power, and the Politics of Animal Control in New York City, 1850–1920,” *The Journal of American History* 98, no. 4 (March 2012): 1003, doi:10.1093/jahist/jar566. Wang uses “canine animal control” as an example of how cities in the 1800s took over functions that were previously the civic obligations of citizens on health and safety issues.

³⁸ Susan Hunter and Richard Brisbin, Jr., *Pet Politics: The Political and Legal Lives of Cats, Dogs, and Horses in Canada and the United States* (West Lafayette, IN: Purdue University Press, 2016), 56.

³⁹ “An Act to Lessen the Dangerous Evils of Canine Madness and Other Injuries Occasioned by Dogs,” in *Acts and Resolves of Massachusetts, 1796–97* (Boston, 1896), 420–421.

⁴⁰ “An Ordinance Establishing Regulations Concerning Dogs,” in *Ordinances of the Corporation of the City of Philadelphia* (Philadelphia, 1812), 245–246.

⁴¹ “An Act Authorizing the City of Boston and Towns in This Commonwealth to Make Bylaws Restraining Dogs Going At Large,” in *Laws of the Commonwealth of Massachusetts* (Boston, 1825), 621.

⁴² See, e.g., “A Law Concerning Dogs,” in *Laws and Ordinances Made and Established by the Mayor, Aldermen, and Commonality of the City of New-York, in Common Council Convened, A.D. 1833–1834* (New York, 1834), 116–117; “Concerning Dogs,” in *By-Laws and Ordinances of the Mayor, Aldermen, and Commonality of the City of New York* (New York, 1845), 513–514; “Of Provisions Concerning Dogs,” in *Ordinances of the Mayor, Aldermen, and Commonality of the City of New York*, ed. D. T. Valentine (New York, 1859), 414–415; “Dogs: Ordinance of May 27, 1828,” in *A Digest of the Ordinances of the Corporation of the City of Philadelphia, and of the Acts of Assembly, Relating Thereto* (Philadelphia, 1834), 92–94; “Dogs,” in *A Digest of the Laws and Ordinances Relating to the City of Philadelphia, In Force on the 12th Day of December, A.D. 1868* (Philadelphia, 1869), 138–139.

⁴³ John Duffy, *The Sanitarians: A History of American Public Health* (1990; repr., Urbana, IL: University of Illinois Press, 1992), 87.

⁴⁴ “An Ordinance in Relation to Dogs,” *Madison Daily Banner*, June 19, 1848.

⁴⁵ Grier, *Pets in America*, 214–215.

⁴⁶ Nona Hengen, *In Pursuit of Compassion: A Centennial History of the Spokane Humane Society, 1897–1997* (Spokane, WA: Spokane Humane Society, 1997), 30.

Part I: The First Era of Sheltering
Chapter 1: Animal Control from the Colonial Era through the 19th Century

female.⁴⁷ St. Louis, Missouri, charged twice as much to license a female dog as a male and ordered policemen to kill any female dogs, registered or not, who were off their owner's property while in heat.⁴⁸

High fees resulted in poor people often not being able to afford licenses, and they risked losing their dogs as a result.⁴⁹ A Boston dog catcher told the story of a woman who had 13 dogs and was too poor to license them. The first time he came to her home to take the dogs she was out, and when he came back the next morning all the dogs had been "spirited away."⁵⁰ Licenses have continued to be a part of animal control up to the present day, but they did not solve the problem of dogs in the streets in the 1800s.

Dog ordinances were often enforced only in the summer because popular opinion held that the danger of rabies was greatest in the summer months.⁵¹ In New York City, for example, the dog ordinances were in effect only during the summer months through the end of the 1800s.⁵² There were frequent summer panics in cities brought on by reports that someone had been attacked by a dog, or had developed rabies.⁵³ The public's belief that rabies was more prevalent in hot weather persisted in spite of evidence that rabies was equally or more common in cold weather.⁵⁴

Instead of having the police catch and kill dogs in the summer, cities sometimes placed a bounty on unregistered or unmuzzled dogs to deputize citizens to kill them. The mayor of New York City reportedly advised police officers early in the 19th century to pay a bounty for unmuzzled dogs brought to the police station in July or August to be killed.⁵⁵ Bounties had been used in colonial times to control wolves. In 1648, for example, Massachusetts adopted a law providing that anyone who killed a wolf within 10 miles of any plantation could collect 10 shillings.⁵⁶ The United States was not the only country that tried to exterminate free roaming dogs by wholesale killing. Great Britain regularly had mass killings of dogs in the 19th century, and Paris had "canicides," such as one in 1879 where 9,479 dogs were killed.⁵⁷

In some cases, the efforts of bounty hunters to kill dogs were arguably more hazardous than the dogs. A man who attempted to shoot a dog with a double-barreled shotgun in 1861 hurt himself severely when the gun exploded and broke his



Figure 4:
This 1826 cartoon illustrates the fear of "mad" dogs. Author unknown. Public domain.

⁴⁷ "The Dog Scoop," *Boston Post*, August 15, 1895.

⁴⁸ "An Ordinance Concerning Dogs," in *The Ordinances of the City of St. Louis, State of Missouri* (St. Louis, 1861), 332–337.

⁴⁹ "Learn the New Dog Law."

⁵⁰ "Slaughter of Stray Dogs," *Boston Daily Globe*, July 29, 1888.

⁵¹ Janet Davis, *The Gospel of Kindness: Animal Welfare and the Making of Modern America* (New York: Oxford University Press, 2016), 92–93; "The Dog Pound," *New York Times*, June 2, 1855.

⁵² Wang, "Dogs and the Making of the American State," 1003n9.

⁵³ "No Hydrophobia Here," *New York Times*, May 29, 1854.

⁵⁴ Blatchford, *Hydrophobia*, 4–8; "Dr. Russel on Hydrophobia," *New York Times*, March 2, 1881.

⁵⁵ "City Dogs," *New York Times*, July 26, 1857.

⁵⁶ *The Laws and Liberties of Massachusetts* (1648; repr., San Marino, CA: Huntington Library, 1998), 54.

⁵⁷ Wasik and Murphy, *Rabid*, 100; Andrew Gardiner, "The Animal as Surgical Patient: A Historical Perspective in the 20th Century," in "Animals and Surgery," special issue, *History and Philosophy of the Life Sciences* 31, no. 3–4 (2009): 358.

Part I: The First Era of Sheltering
Chapter 1: Animal Control from the Colonial Era through the 19th Century

arm.⁵⁸ The dog was unharmed. Even the police could be careless when panicked over a presumably mad dog. Illustrations of the time show police officers shooting at dogs with citizens nearby.⁵⁹ As late as 1908 Chicago had a street roundup of sorts, with 10 policemen, “Armed with rapid fire revolvers,” shooting “every dog found unmuzzled or untagged.”⁶⁰

An alternative to paying citizens a bounty to kill dogs was for a city to designate specific people as dog catchers. Dog catchers were typically paid based on the number of dogs killed, and they also sometimes received part or all of license and reclaim fees. There are mentions in local newspapers of dog catchers in 1834 in Moorhead, Minnesota,⁶¹ and in 1838 in Philadelphia.⁶² By 1841, dog catchers were common enough in American cities that there was a song about them. It was a parody on the popular song “Woodman spare that tree!”⁶³ and started off “Dog catcher, spare that dog! Touch not a single hair.”⁶⁴ The song, although it was lighthearted, illustrated the brutality of dog catching at the time, for the dog catcher used a club. The song also illustrated the interference that dog catchers often encountered from the public. The last lines of the song, directed to the dog, were: “While I’ve a hand to save thee, his club shall harm thee not.” Many of the dog ordinances enacted by cities in the 1800s provided for substantial fines for people who interfered with a dog catcher.⁶⁵

By the mid-1800s, cities were beginning to establish municipal dog pounds and require that dogs in violation of city ordinances be brought to the pounds rather than killed in the street.⁶⁶ Pounds had several benefits over street killings. It was part of the culture in the 1800s to allow dogs to roam,⁶⁷ and many owned dogs were killed by bounty hunters and dog catchers. Holding dogs in a pound for a day or two before killing them allowed owners to reclaim their dogs. Allowing owners to reclaim dogs gave cities a chance to require the owners to pay registration and reclaim fees, which offset the cost of dog control. And cities could make additional revenue by selling the valuable purebred dogs who were occasionally brought to the pound and not reclaimed.⁶⁸ Another benefit of pounds was that doing the killing at the pound got it out of the sight of citizens.

As will be discussed further in later chapters, pounds did not solve the problem of the brutality of dog control in the 1800s. There were 43 successful prosecutions of dog catchers for cruelty in New York City in the years from 1877 to 1880, for example.⁶⁹ As late as 1905, a list of “illustrative cruelties” that one SPCA prosecuted against dog catchers included “impounding without wholesome food and water, beating, clubbing and abusing while in pound; overcrowding dog catcher’s wagon and leaving it stand in scorching

⁵⁸ “Accident,” *Philadelphia Inquirer*, March 22, 1861.

⁵⁹ Bernard Unti, “The Quality of Mercy: Organized Animal Protection in the United States, 1866–1930” (PhD diss., American University, 2002), 94n32.

⁶⁰ “War Against ‘Mutts’: Ten Chicago Cops Scour Streets to Kill Unmuzzled, Untagged Dogs,” *Philadelphia Inquirer*, August 2, 1908.

⁶¹ “Scout ‘Mayor’ Appoints Rival Candidate to Job,” *Moorhead Daily News*, February 1, 1834.

⁶² “Interference with Public Officers,” *Washington National Intelligencer*, August 14, 1838.

⁶³ The lyrics to the original song were written as a poem by George Pope Morris and published in the *New York Evening Mirror* in 1837. The music was written by Henry Russell. “Biography of George Pope Morris,” *Poem Hunter*, accessed March 31, 2017, <http://www.poemhunter.com/george-pope-morris/biography/>.

⁶⁴ “City Lyrics,” *Boston Morning Post*, November 22, 1841; “Dog-Catcher Spare That Dog!,” *Hocking Sentinel*, June 24, 1846.

⁶⁵ See, e.g., “An Ordinance Establishing Regulations Concerning Dogs,” 245–246.

⁶⁶ The earliest “pounds” in the United States were Colonial-era enclosures for wayward livestock, and were designed to hold the animals until their owners could redeem them by paying a fee. For example, the Massachusetts colony provided for a livestock pound in its laws of 1648. *Laws and Liberties of Massachusetts*, 44–45.

⁶⁷ Teigen, “Legislating Fear,” 154, 157; Jack Larkin, *The Reshaping of Everyday Life, 1790–1840* (1988; repr., New York: Harper & Row, 1989), 128–129.

⁶⁸ “The Dog Pound and the Fate of its Inhabitants,” *New York Times*, October 9, 1857.

⁶⁹ Unti, “Quality of Mercy,” 475.

Part I: The First Era of Sheltering
Chapter 1: Animal Control from the Colonial Era through the 19th Century

sun with no water for dogs.”⁷⁰ The mayor of Atlantic City once temporarily closed the dog pound after allegations that dogs were “starved and maltreated.”⁷¹

Anti-cruelty laws developed slowly in the United States. An early provision for legal guidance, the 1641 “Body of Liberties” prepared for the Massachusetts Bay Colony, stated that: “No man shall exercise any Tyranny or Crueltie towards any brute Creature which are usuallie kept for man’s use.”⁷² An almost identical provision was included in the first compilation of fundamental laws for the colony in 1648.⁷³ This early anti-cruelty law proved to be an aberration, though, and it was not replicated in the period from 1648 through the early 1800s. In the absence of anti-cruelty statutes, common law rules against nuisance behavior and malicious mischief were sometimes invoked in the early and mid-1800s to prosecute cruel treatment of animals.⁷⁴

Even when anti-cruelty statutes began to be enacted, their scope was often restricted to economically valuable livestock. In 1821, the Maine legislature considered an anti-cruelty statute, but no legislative history has survived that reveals the motivation for the law.⁷⁵ The language of the statute, which prohibited “any person” from “cruelly beating any horse or cattle,” was aimed at what was probably the most obvious type of animal cruelty in those days, the beating of beasts of burden to make them pull heavy loads. The Maine statute made it clear that such beating was not considered a serious crime, as the maximum penalty was a fine of \$5.00, or a jail term not to exceed 30 days.⁷⁶ An 1829 law in the state of New York made it a misdemeanor, with a jail term of up to one year, to “maliciously and cruelly beat or torture” horses, cattle, and sheep.⁷⁷

Protection for dogs and cats was included in a comprehensive anti-cruelty law enacted in 1867 in New York State, which applied to “all living creatures.”⁷⁸ This law recognized a value in preventing suffering that was not based on the ownership status or economic value of an animal. Other states enacted anti-cruelty laws of one form or another in succeeding years, and by the early 1900s, all the states had anti-cruelty provisions.⁷⁹

Aside from anti-cruelty laws, dogs and cats in the United States in the late 1800s had an uncertain legal status. It was well established that domestic animals who had economic value were personal property, and an owner’s interest in those animals was protected by law.⁸⁰ This “property” status distinguished animals like horses, sheep, and cattle from wild animals, who in their wild state did not have any realized economic

⁷⁰ Roswell McCrea, *The Humane Movement: A Descriptive Survey* (New York: Columbia University Press, 1910), 243–244.

⁷¹ “Atlantic’s Dog Pound Closed,” *Philadelphia Inquirer*, October 21, 1905.

⁷² “The Massachusetts Body of Liberties, 1641,” *Hanover Historical Texts Project*, last modified March 8, 2012, <http://history.hanover.edu/texts/masslib.html#ms>. The Body of Liberties, which was originally written by Nathaniel Ward, was adopted by the General Court for a three-year trial period in 1641 but was not construed at that time as fundamental law. Richard Dunn, introduction to *Laws and Liberties of Massachusetts*, vi. Some have interpreted the statements about animals in the Body of Liberties as early animal-rights provisions. The provision for animals, though, unlike provisions for various categories of humans, did not contain the word “liberties” in the heading, and the content of the animal provision was substantively an anti-cruelty rule rather than a statement of inherent rights. The 1648 law made this explicit when it used the heading “Cruelty” for the provision about animals. *Laws and Liberties of Massachusetts*, 16.

⁷³ *Laws and Liberties of Massachusetts*, 16.

⁷⁴ Emily Leavitt and Diane Halverson, “The Evolution of Anti-Cruelty Laws in the United States,” chap. 1 in *Animals and Their Legal Rights: A Survey of American Laws from 1641 to 1990*, 4th ed. (Washington, DC: Animal Welfare Institute, 1990), 2; David Favre and Vivien Tsang, “The Development of Anti-Cruelty Laws During the 1800s,” *Detroit College of Law Review* (Spring 1993): 5–6, <http://digitalcommons.law.msu.edu/cgi/viewcontent.cgi?article=1146&context=facpubs>.

⁷⁵ Favre and Tsang, “The Development of Anti-Cruelty Laws,” 7–8.

⁷⁶ *Ibid.*, 9.

⁷⁷ *Ibid.*, 9–10.

⁷⁸ New York Revised Statutes 1867: Chapter 375: Sections 1–10.

⁷⁹ Leavitt and Halverson, “The Evolution of Anti-Cruelty Laws,” 3–4.

⁸⁰ David Favre, “Living Property: A New Status for Animals Within the Legal System,” *Marquette Law Review* 93 (2010): 1026–1027, <http://digitalcommons.law.msu.edu/facpubs/136/>.

Part I: The First Era of Sheltering
Chapter 1: Animal Control from the Colonial Era through the 19th Century

value.⁸¹ The legal status of dogs and cats, who were domesticated, but usually had little or no economic value, was somewhere in between. An 1897 Supreme Court case upheld a Louisiana state law that required that a dog had to be licensed before civil damages could be collected for its negligent killing.⁸² The Court held that dogs and cats, unlike horses and other livestock, had “no intrinsic value” and that the property interest in them was “of an imperfect or qualified nature” that could be regulated by the states. In the 20th century, state and local governments devoted considerable attention to regulating cats and dogs, but the legal status of feral cats is still unspecified in many jurisdictions.⁸³

Toward the end of the 19th century, a major development in medicine helped improve the social status of homeless dogs. Louis Pasteur, a French scientist, reported in 1884 on his success in protecting dogs from developing rabies by giving them a vaccine.⁸⁴ The first human subject for the vaccine was a nine-year-old boy who had been bitten by a rabid dog on July 4, 1885.⁸⁵ The boy was brought to Pasteur two days later, and over a period of 10 days he received the vaccine treatment. The child never developed rabies symptoms and his health remained excellent.



Figure 5:
Boy bitten by dog in Tennessee receives rabies vaccine. By Commonwealth Fund photographer. Public domain.

Many more people came to Pasteur after this successful trial, and by 1886, Pasteur had vaccinated 350 people with only one death from rabies⁸⁶. In New York City, post-exposure rabies vaccination for people was available by the 1890s.⁸⁷ A drug company in Philadelphia put a rabies treatment kit on the market in 1911 that allowed doctors without any specialized training to administer the treatment.⁸⁸ A rabies vaccine for dogs was widely available by the 1930s.⁸⁹ The fear of rabies faded, and summer roundups and bounties on dogs became things of the past.

Just as homeless dogs were greatly affected by the public’s fear of rabies throughout the 1800s, homeless cats (including feral cats) were greatly affected by efforts to clean up cities in the late 1800s and early 1900s. Scientists understood by then that the large numbers of horses, pigs, cows, and other animals in cities were instrumental in the spread of infectious diseases.⁹⁰ In the period from the end of the Civil War to the early 1900s, public health advocates led a movement to clean

⁸¹ *Sentell v. New Orleans & Carrollton Railroad Company*, 166 U.S. 898 (1897).

⁸² *Ibid.*

⁸³ Hunter and Brisbin, *Pet Politics*, 287.

⁸⁴ James Steele and Peter Fernandez, “History of Rabies and Global Aspects,” in *The Natural History of Rabies*, 2nd ed., ed. George Baer (Boca Raton: CRC Press, 1991), 12–13.

⁸⁵ Pearce, “Louis Pasteur and Rabies,” 82.

⁸⁶ *Ibid.*; Steele and Fernandez, “History of Rabies.”

⁸⁷ Wang, “Dogs and the Making of the American State,” 1011.

⁸⁸ Diane Wendt, “Surviving Rabies 100 Years Ago,” *Smithsonian*, October 28, 2013, <http://americanhistory.si.edu/blog/2013/10/surviving-rabies-100-years-ago.html>.

⁸⁹ Wasik and Murphy, *Rabid*, 155. Rabies still kills almost 70,000 people per year, and there are countries where rabies transmission from dogs to humans remains a serious problem. Felix Lankester et al., “Implementing Pasteur’s Vision for Rabies Elimination,” *Science* 345 (September 2014): 1562, doi:10.1126/science.1256306.

⁹⁰ Duffy, *The Sanitarians*, 126.

Part I: The First Era of Sheltering
Chapter 1: Animal Control from the Colonial Era through the 19th Century

up the larger cities, including removing livestock from city centers.⁹¹ Horses also disappeared from cities in the early 1900s, as they were replaced by the automobile.⁹²

The removal of cattle and horses from cities appears to have had a profound effect on outdoor cats. Studies in the 1980s in Baltimore and Brooklyn indicated that in an urban environment shelter can be more of a limiting factor for outdoor cats than food.⁹³ The disappearance of horse and dairy stables from cities in the late 1800s and early 1900s, as well as other clean-up efforts by public health officials, greatly decreased the food and shelter available to cats.⁹⁴ By the latter decades of the 1800s, newspapers in major cities were full of complaints about starving and nuisance cats. Pressure from the public resulted in officials in many cities expanding animal control to include cats as well as dogs.

Animal control, whether for dogs or cats, originated to protect people from animals, and in the years before the Civil War, little thought was given to humane treatment of the animals. That changed in the period from 1866 to 1920, the first era of the humane movement in the United States. The next three chapters describe how the humane movement created public-private partnerships for animal care and control, including cats, in each of the three leading cities of the humane movement—Philadelphia, New York, and Boston.

⁹¹ Ibid., 175–190, 205–218; Susan Jones, *Valuing Animals: Veterinarians and Their Patients in Modern America* (Baltimore: Johns Hopkins University Press, 2003), 18–22, 37–38; Wang, “Dogs and the Making of the American State,” 1010.

⁹² There were only 4,192 automobiles sold in the United States in 1900, but in just 12 years that number rose to 356,000. Morris, “From Horse Power to Horsepower,” 8.

⁹³ Robert Calhoun and Carol Haspel, “Urban Cat Populations Compared by Season, Subhabitat, and Supplemental Feeding,” *Journal of Animal Ecology* 58, no. 1 (February 1989): 327, doi:10.2307/5003; Carol Haspel and Robert Calhoun, “Activity Patterns of Free-Ranging Cats in Brooklyn, New York,” *Journal of Mammalogy* 74, no. 1 (February 1993): 3, doi:10.2307/1381900.

⁹⁴ The number of cats impounded by the ASPCA rose from 24,140 in 1895, soon after the ASPCA had started doing animal control for New York City, to 219,506 in 1934. By 1994, cat intake had declined to 27,366. Stephen Zawistowski et al., “Population Dynamics, Overpopulation, and the Welfare of Companion Animals: New Insights on Old and New Data,” *Journal of Applied Animal Welfare Science* 1, no. 3 (1998): 202, table 4, doi:10.1207/s15327604jaws0103_1. Many factors other than the number of cats in the environment can affect cat intake, but the extent of the change in intake by the ASPCA may indicate that the number of outdoor cats in New York City peaked in the 1930s.

Chapter 2: Philadelphia: Home of the First Animal Shelter

A humane movement began in Europe and Great Britain in the first half of the 19th century. The first permanent humane organization in the world was the Society for the Prevention of Cruelty to Animals (SPCA), founded in Great Britain in 1824.¹ Queen Victoria recognized the organization in 1840, and it was afterward known as the Royal SPCA. Humane organizations were established in Germany, France, and Austria in the years from 1839 to 1846.² After the Civil War ended in 1865, the United States saw the formation of several important humane organizations modeled on the ones in Europe and Great Britain.³

Three cities—New York, Philadelphia, and Boston—became the centers of the early humane movement in the United States.⁴ The first humane organization in the United States, the American Society for the Prevention of Cruelty to Animals (ASPCA), was granted a charter on April 10, 1866 in New York City.⁵ The Pennsylvania SPCA began operations in Philadelphia on June 21, 1867, but was not chartered until April 4, 1868.⁶ In the meantime, the Massachusetts SPCA was founded in Boston and granted a charter on March 23, 1868.⁷ Several other SPCAs were formed in this time period as well.⁸

The early SPCAs were often granted police powers to enforce anti-cruelty laws.⁹ This new enforcement mechanism worked hand-in-hand with stronger anti-cruelty statutes that were enacted following the Civil War, beginning with statutes passed in 1866 and 1867 in New York State at the instigation of



Figure 6:
Water fountains for horses were a priority for early humane societies and SPCAs. Photo from the collection of Women's Animal Center, America's First Animal Shelter – formerly known as Women's Human Society for the Prevention of Cruelty to Animals.

¹ Roswell McCrea, *The Humane Movement: A Descriptive Survey* (New York: Columbia University Press, 1910), 5–6; Sydney Coleman, *Humane Society Leaders in America* (Albany, NY: American Humane Association, 1924), 26–29; Harriet Ritvo, "Animals in Nineteenth-Century Britain: Complicated Attitudes and Competing Categories," chap. 6 in *Animals and Human Society: Changing Perspectives*, ed. Aubrey Manning and James Serpell (1994; repr., New York: Routledge, 2011), 108.

² McCrea, *Humane Movement*, 9–10.

³ Historian Janet Davis posits that the humane movement in the United States grew out of the Second Great Awakening, a protestant revival movement that began in the late 18th century and emphasized kindness toward "the least among us," including animals. Janet Davis, *The Gospel of Kindness: Animal Welfare and the Making of Modern America* (New York: Oxford University Press, 2016), 27–38.

⁴ Jessica Wang, "Dogs and the Making of the American State: Voluntary Association, State Power, and the Politics of Animal Control in New York City, 1850–1920," *Journal of American History* 98, no. 4 (March 2012): 1004, doi:10.1093/jahist/jar566; James Turner, *Reckoning with the Beast: Animals, Pain, and Humanity in the Victorian Mind* (Baltimore: Johns Hopkins University Press, 1980), 52.

⁵ McCrea, *Humane Movement*, 11; William Swallow, *Quality of Mercy: History of the Humane Movement in the United States* (Boston: Mary Mitchell Humane Fund, 1963), 11–13; Marion Lane and Stephen Zawistowski, *Heritage of Care: The American Society for the Prevention of Cruelty to Animals* (Westport, CT: Praeger, 2008), 18.

⁶ McCrea, *Humane Movement*, 12–13; Swallow, *Quality of Mercy*, 13–16.

⁷ McCrea, *Humane Movement*, 12; Swallow, *Quality of Mercy*, 16–21.

⁸ These included a branch of the ASPCA in Buffalo (founded in 1867 by Marjorie Lord, former U.S. president Millard Fillmore, and others), that eventually became the SPCA Serving Erie County, and the New Jersey and San Francisco SPCAs, chartered respectively on April 3 and April 18, 1868. McCrea, *Humane Movement*, 13; Swallow, *Quality of Mercy*, 21–24; Stephen Zawistowski, *Companion Animals in Society* (Clifton Park, NY: Thomson Delmar Learning, 2008), 59.

⁹ Susan Hunter and Richard Brisbin, Jr., *Pet Politics: The Political and Legal Lives of Cats, Dogs, and Horses in Canada and the United States* (West Lafayette, IN: Purdue University Press, 2016), 53.

Part I: The First Era of Sheltering
Chapter 2: Philadelphia: Home of the First Animal Shelter

Henry Bergh, founder of the ASPCA.¹⁰ The 1867 New York law included dogs and cats in its scope, protecting “any living creature” from abuse or neglect.¹¹ It also prohibited dog fighting, and provided that impounded animals had to be given food and water. Several other states subsequently enacted anti-cruelty statutes that were influenced by New York’s 1867 law.¹² The deputizing of SPCA employees to enforce anti-cruelty laws was an early example of the mix of public and private functions that is still an important factor in animal sheltering in the United States today.¹³

Although the SPCAs were concerned with cruelty to all animals, in their early years, they spent a substantial amount of their resources on citing and arresting people who beat or otherwise abused beasts of burden, particularly horses.¹⁴ Horses were the cars, trucks, buses, and light rail of the times.¹⁵ It was common in city streets to see men beating exhausted and overburdened horses who were struggling to move heavy loads.¹⁶ Horses were sometimes not fed well, and cities often lacked sufficient water troughs for them. If a horse was injured or fell, it might be left where it was.¹⁷

The officers of the various SPCAs had to walk a fine line in enforcement, because overworking of horses often occurred due to the poverty of owners who could not afford big enough teams for the loads they needed to move. One case prosecuted by the Spokane SPCA involved a “poor man” who supported himself and his two children by hauling wood.¹⁸ His wife was in an insane asylum, and he told the court that if he were jailed, he would have to “deliver the children over to the county.” Humane officers often tried to consider the problems of the poor and sometimes worked to find help for them rather than prosecuting them.¹⁹

Beasts of burden may have been the most obvious victims of cruelty, but many other types of animals were subject to cruelty as well. Cattle transported from ranches in the west were shipped to slaughter on overcrowded rail cars and went days without food, water, or rest.²⁰ Calves were tied up and stacked in piles for transport to slaughter, and bled to make their meat whiter.²¹ Dairy cows were kept confined in tiny stalls in filthy stables and fed on swill.²² Blood sports such as bull baiting, dog fighting, and cock fighting were common, as were pigeon shoots and killing of birds for their feathers. All of these issues were of concern to the early SPCAs.

¹⁰ David Favre and Vivien Tsang, “The Development of Anti-Cruelty Laws During the 1800’s,” *Detroit College of Law Review* (Spring 1993), 14–18, <http://digitalcommons.law.msu.edu/cgi/viewcontent.cgi?article=1146&context=facpubs>; Emily Leavitt and Diane Halverson, “The Evolution of Anti-Cruelty Laws in the United States,” chap. 1 in *Animals and Their Legal Rights: A Survey of American Laws from 1641 to 1990*, 4th ed. (Washington, DC: Animal Welfare Institute, 1990), 5–7.

¹¹ New York Revised Statutes 1867: Chapter 375: Sections 1–10.

¹² Favre and Tsang, “Development of Anti-Cruelty Laws,” 20–22.

¹³ Wang, “Dogs and the Making of the American State,” 998–999.

¹⁴ McCrea, *Humane Movement*, 59–60; Bernard Unti, “The Quality of Mercy: Organized Animal Protection in the United States, 1866–1930” (PhD diss., American University, 2002), 436–438.

¹⁵ Katherine Grier, *Pets in America: A History* (Chapel Hill: University of North Carolina Press, 2006), 187–195.

¹⁶ McCrea, *Humane Movement*, 59, 151; Grier, *Pets in America*, 150–151.

¹⁷ McCrea, *Humane Movement*, 153.

¹⁸ Nona Hengen, In Pursuit of Compassion: A Centennial History of the Spokane Humane Society, 1897–1997 (Spokane, WA: Spokane Humane Society, 1997), 36–37.

¹⁹ Unti, “Quality of Mercy,” 224.

²⁰ *Ibid.*, 227–260.

²¹ Coleman, *Humane Society Leaders*, 42, 95.

²² John Duffy, *The Sanitarians: A History of American Public Health* (1990; repr., Urbana: University of Illinois Press, 1992), 183–184; Unti, “Quality of Mercy,” 118–119.

Part I: The First Era of Sheltering
Chapter 2: Philadelphia: Home of the First Animal Shelter

In addition to SPCAs, many cities had organizations designated as “humane societies.”²³ Early humane societies commonly served both animals and children.²⁴ They were less likely than SPCAs to have officers with delegated police powers, and often left street patrolling and enforcement of the anti-cruelty laws to the SPCAs. As time went by though, the roles of humane societies and SPCAs became intertwined. The terms “humane society” and “SPCA” were sometimes used interchangeably by the press.

The American Humane Association (AHA) was founded as a national umbrella group for humane organizations in 1877, but it was not incorporated until 1903.²⁵ The AHA struggled in its early years, but eventually stabilized, and it still exists today.²⁶ By 1922, the AHA listed 539 active member organizations, of which 175 were exclusively for animal protection, 57 exclusively for child protection, and 307 for both.²⁷

Many of the early humane organizations were reluctant to get involved with dog catching or dog pounds. In New York City, for example, Henry Bergh was afraid that if the ASPCA took over impounding and disposing of dogs, it would require so much time and money that few resources would be left for anything else.²⁸ As it happened, the earliest SPCA to provide a solution for the cruelty of city dog pounds was an unusual one founded in Philadelphia that was run entirely by women.

In the United States, before the Civil War, women were generally barred by social custom from taking part in the running of a public institution, unless the institution’s membership was limited to women.²⁹ This gradually began to change in the social upheavals following the Civil War, but the earliest SPCAs, including the ASPCA, the Pennsylvania SPCA, and the Massachusetts SPCA, were run by men.

Emily Appleton, who was the cofounder of the Massachusetts SPCA in Boston, did not feel that she could even attend the organization’s first meeting, much less accept a board position, without offending contemporary sensibilities.³⁰ Marjorie Lord, the catalyst for the formation of the Erie County SPCA in 1867, was unable to serve on its board.³¹ Well into the 1900s, the SPCAs relegated women to “women’s auxiliaries.”³² One early historian of the humane movement described the ASPCA Women’s Auxiliary as having been formed to “materially assist in humane work for animals while not interfering with the work of the American S.P.C.A.”³³ The ASPCA would not have a female board member until 1972.³⁴

²³ Zawistowski, *Companion Animals in Society*, 74.

²⁴ McCrea, *Humane Movement*, 14, 136–137.

²⁵ Swallow, *Quality of Mercy*, 161.

²⁶ Coleman, *Humane Society Leaders*, 247–270; Unti, “Quality of Mercy,” 297–302.

²⁷ William Shultz, *The Humane Movement in the United States, 1910–1922* (New York: Columbia University Press, 1924), 14.

²⁸ Zawistowski, *Companion Animals in Society*, 73.

²⁹ Coleman, *Humane Society Leaders*, 146, 177; Diane Beers, *For the Prevention of Cruelty: The History and Legacy of Animal Rights Activism in the United States* (Athens: Swallow Press/Ohio University Press, 2006), 9.

³⁰ Turner, *Reckoning with the Beast*, 49; Beers, *For the Prevention of Cruelty*, 48–49.

³¹ Zawistowski, *Companion Animals in Society*, 59.

³² As late as 1917, the Pennsylvania SPCA formed a separate Women’s Auxiliary (which was supervised by a man) to manage water troughs and the yearly horse parade. Shultz, *Humane Movement in the United States*, 71; Coleman, *Humane Society Leaders*, 149–150.

³³ Shultz, *Humane Movement in the United States*, 69.

³⁴ Lane and Zawistowski, *Heritage of Care*, 39.

Part I: The First Era of Sheltering
Chapter 2: Philadelphia: Home of the First Animal Shelter



Figure 7:
Caroline Earle White, founder of the first animal shelter in the United States. Photo from the collection of Women's Animal Center, America's First Animal Shelter – formerly known as Women's Humane Society for the Prevention of Cruelty to Animals.

The Pennsylvania SPCA, like the Massachusetts and Erie County SPCAs, had a female founder who was not named as an officer or board member. Caroline Earle White was born in 1833 to a prominent Quaker family in Philadelphia.³⁵ Her father, Thomas Earle, was a lawyer and journalist. He supported the abolition of slavery and ran for vice president of the United States in 1840 on the ticket of the anti-slavery Liberty Party.³⁶ Although White had many interests and was active in several different types of organizations, her life's work was the humane movement. Like many humane activists of the 1800s, she was originally inspired to fight animal cruelty by the sight of draft animals being beaten and abused, something that was common on the streets of Philadelphia when she was growing up.³⁷

Before the Civil War broke out, White had been interested in establishing some organized method for fighting animal cruelty, but the war interrupted her plans.³⁸ After the war ended, she saw a notice in the newspaper about Henry Bergh's formation of the ASPCA in New York City in 1866. She visited Bergh, who gave her information on how to set up an SPCA. White got to work to collect signatures of supporters, which was necessary to gain a state charter. She

was joined in the incorporation effort by M. Richards Mucklé, a newspaper executive who had a similar goal. They incorporated the Pennsylvania SPCA in April 1868. Although White was the principle founder, she was not appointed to the board of directors or any other official position in the organization.³⁹

Following this experience, White decided to found an SPCA to be managed and run by women. On April 14, 1869, she held the first meeting of the Women's Branch of the Pennsylvania SPCA, with about 30 women in attendance.⁴⁰ The Women's Branch was nominally a part of the Pennsylvania SPCA at first, but in practice it operated as an independent SPCA from the beginning.⁴¹ Unlike the women's auxiliaries, which were controlled by male officials of the parent SPCAs, the Women's Branch was free to tackle whatever its members wanted to take on.⁴² The organization drew wide support from the women of Philadelphia, and

³⁵ Jane Campbell, "Mrs. Caroline Earle White, Reformer," in *Records of the American Catholic Historical Society of Philadelphia, Volume 33* (Philadelphia: American Catholic Historical Society of Philadelphia, 1922), 29, 31.

³⁶ *Ibid.*, 29–30.

³⁷ *Ibid.*, 37.

³⁸ Mary Lovell, "Mrs. Caroline Earle White: A Retrospect," *Journal of Zoöphily* 25, no. 9 (September 1916), 131; Campbell, "Mrs. Caroline Earle White, Reformer," 37–38.

³⁹ Mary Lovell, "Caroline Earle White," in *Notable Women of Pennsylvania*, ed. Gertrude Biddle and Sarah Lowrie (Philadelphia: University of Pennsylvania Press, 1942), 187.

⁴⁰ Coleman, *Humane Society Leaders*, 180; Unti, "Quality of Mercy," 154–155.

⁴¹ Mary Lovell, Outline of the History of the Women's Pennsylvania Society for the Prevention of Cruelty to Animals: From Its Foundation April 14, 1869, to December 31, 1899 (Philadelphia: Women's Pennsylvania Society for the Prevention of Cruelty to Animals, 1900), 4, 27, 57–58. The Women's Branch was ostensibly part of the Pennsylvania SPCA until 1897, when it separated itself completely and took the name of Women's Pennsylvania SPCA. Lovell, Outline, 57–58. It still exists today, under the name Women's Humane Society. The Women's Humane Society carries on the tradition of female leadership, with a board composed entirely of women. Lovell was a member of the Women's Branch from the time it was founded, and acted as the group's secretary for more than 25 years. "Portrait Donated," *Philadelphia Inquirer*, Mar. 11, 1922. White worked closely on many projects with Lovell, who became a director of the AHA. Lovell was one of the early lobbyists for animal issues with the Pennsylvania state government, and was active in many other ways in animal welfare. Coleman, *Humane Society Leaders*, 186. She was also very active in the Woman's Christian Temperance Union (WCTU), and "established and led the WCTU's Department of Mercy." Unti, "Quality of Mercy," 277.

⁴² Unti, "Quality of Mercy," 154–155. Social mores at that time would not have allowed women to do street enforcement of anti-cruelty laws, but the Women's Branch hired agents for that work. "First Anniversary of the W. B. O. T. S. F. T. P. O. C. T. A.," *Philadelphia Inquirer*, April 7, 1870.

Part I: The First Era of Sheltering
Chapter 2: Philadelphia: Home of the First Animal Shelter

within its first year its membership grew to almost 400.⁴³ Henry Bergh and the mayor of Philadelphia spoke at the first annual meeting of the Women's Branch and congratulated its members on their success.⁴⁴ White was elected president of the Women's Branch by its members each year from the time it was founded until her death in 1916.⁴⁵

White did not restrict her humane activities to the Women's Branch. She was a supporter of the AHA from the time she attended its first meeting as a delegate in 1877, and served on its board for several years.⁴⁶ She sent Women's Branch agents to other cities to encourage formation of local SPCAs.⁴⁷ She was "crucial" in the formation in 1876 of the Pennsylvania Society for the Prevention of Cruelty to Children.⁴⁸ She, along with Mary Lovell and Adele Biddle, founded the American Anti-Vivisection Society at a meeting called by the Women's Branch in 1883, and White was corresponding secretary for the organization until her death.⁴⁹ She founded a humane magazine in 1892 and served as its editor.⁵⁰

Women's Branch officials inspected horses, intervened when horses were being beaten, and promoted humane education.⁵¹ White was personally instrumental in the passage of a federal law regulating the long distance transport of animals for slaughter, and the Women's Branch put much effort into enforcing the law.⁵² White was a vegetarian, and in 1899 she wrote that if people were aware of the cruelties that cattle suffered in transport there might be "a large accession to the vegetarian ranks."⁵³ She opposed pigeon shooting and fox hunts and was able to obtain legal protection for some wild birds.⁵⁴ The Women's Branch met many setbacks in working for humane treatment of animals, but in the words of Mary Lovell, the group's unofficial historian, White "regarded defeat as but one of the steps to accomplishment."⁵⁵

White and other Women's Branch members were very concerned about the city's cruel treatment of stray dogs. Philadelphia in the 1860s had a summer dog roundup season for unmuzzled and unregistered dogs.⁵⁶ About 2,000 dogs were captured each year.⁵⁷ The dog catchers lassoed animals and dragged them to the dog wagons, which could be some distance off, and then threw them into the wagons.⁵⁸ The Philadelphia roundups sometimes included police officers shooting at the dogs.⁵⁹

⁴³ Lovell, *Outline*, 3, 5.

⁴⁴ "First Anniversary."

⁴⁵ Lovell, *Outline*, 63–64; Coleman, *Humane Society Leaders*, 180.

⁴⁶ Coleman, *Humane Society Leaders*, 183.

⁴⁷ *Ibid.*

⁴⁸ Unti, "Quality of Mercy," 310.

⁴⁹ Coleman, *Humane Society Leaders*, 183, 204–205; Craig Buettinger, "Women and Antivivisection in Late Nineteenth-Century America," *Journal of Social History* 30, no. 4 (Summer 1997), 857–858, doi:10.1353/jsh/30.4.857.

⁵⁰ The magazine was called the *Journal of Zoöphily*, later renamed *The Starry Cross*. Coleman, *Humane Society Leaders*, 184; Lovell, *Outline*, 50–51.

⁵¹ Lovell, *Outline*.

⁵² *Ibid.*, 7, 11–14, 18–19, 30–31, 41–42, 47, 52, 54, 57.

⁵³ *Ibid.*, 61.

⁵⁴ Coleman, *Humane Society Leaders*, 183, 222.

⁵⁵ Lovell, *Outline*, 63.

⁵⁶ "An Hour at the Dog Pound," *Philadelphia Inquirer*, July 16, 1861; "The Dog Registry," *Philadelphia Inquirer*, December 3, 1860.

⁵⁷ "Enforcement of the Ordinance Against Dogs," *Philadelphia Inquirer*, June 2, 1862. In New York, by comparison, 5,860 dogs were taken in by the pound during the full season in 1860, and that was only a fraction of the dogs in the city. *The American Agriculturist, for the Farm, Garden, and Household* 19 (New York, 1860), 303.

⁵⁸ Unti, "Quality of Mercy," 165.

⁵⁹ *Ibid.*

Part I: The First Era of Sheltering
Chapter 2: Philadelphia: Home of the First Animal Shelter

The city's dog pound was a shed with pens about 10' square where the dogs were packed together.⁶⁰ An 1855 dog control ordinance provided for a 24-hour hold time to allow owners to reclaim their dogs,⁶¹ and unclaimed dogs were killed twice a week.⁶² During the hold time, the dogs were given water, at least sometimes, but no food.⁶³ Dogs were killed by being hung up with ropes or chains, then, while one person held a dog's back legs, another person would hit it in the head with a club to kill it.⁶⁴ This was done in front of the other dogs who were still alive.⁶⁵ Sometimes a dog was just injured, and would regain consciousness in the cart used to haul dead dogs away.⁶⁶ The head dog catcher received 50 cents per dog that he caught and killed.⁶⁷

It was not unusual for city dog pounds in the 1860s and 1870s to use clubbing as a method of killing dogs. An 1874 newspaper article about the Oakland, California dog pound described how dogs were clubbed to death.⁶⁸ In St. Louis, a man with a club went into the pens, chased the dogs, and killed them in front of each other.⁶⁹ Dogs often required multiple blows to kill them.

White believed that killing dogs by beating them to death was "barbarous," and the fact that it had gone on for so many years in Philadelphia was "a disgrace to our city."⁷⁰ At the third meeting of the fledgling Women's Branch in June 1869, its members took action by voting unanimously to provide "a Refuge for lost and homeless dogs."⁷¹ To make sure that the "extreme cruelty" of the city's methods of "catching and disposing of dogs" was stopped, the women decided to apply to the city to be awarded a contract to take over dog catching and run the city pound.⁷²

The women persevered in spite of "opposition, misrepresentation, and ridicule" from journalists who were, for the most part, "unable to entertain seriously the idea of systematic effort to abate or prevent the sufferings of dumb animals."⁷³ White persuaded Philadelphia's leaders to grant a contract to the Women's Branch for dog impoundment and disposition, and in 1870, the Women's Branch established the first public dog "shelter" in the United States.⁷⁴ The arrangement was formalized by the passage of a city ordinance in 1871 that allowed the mayor to make a contract between the city and the Women's Branch each year for dog control and disposition.⁷⁵

⁶⁰ "An Hour at the Dog Pound"; "Slaughter of Dogs," *Philadelphia Inquirer*, September 9, 1861.

⁶¹ "Dogs," in A Digest of the Laws and Ordinances Relating to the City of Philadelphia, In Force on the 12th Day of December, A.D. 1868 (Philadelphia, 1869), 138–139.

⁶² "An Hour at the Dog Pound."

⁶³ *Ibid.*

⁶⁴ *Ibid.*; Unti, "Quality of Mercy," 165, 169. A journalist reported that during a visit to the pound the head dog-catcher chastised an assistant for failing to kill a dog with one blow, and that the head dog-catcher returned dogs for free to two poor women who could not afford the fee. "An Hour at the Dog Pound."

⁶⁵ "An Hour at the Dog Pound;" Unti, "Quality of Mercy," 169.

⁶⁶ Unti, "Quality of Mercy," 165–66.

⁶⁷ "Enforcement of the Ordinance Against Dogs."

⁶⁸ "A Brutal Scene," *Oakland Daily Tribune*, July 27, 1874.

⁶⁹ "Disgusting Brutality: Killing Dogs in the St. Louis Dog Pound," *New York Times*, July 19, 1877.

⁷⁰ "First Anniversary."

⁷¹ Unti, "Quality of Mercy," 167.

⁷² Lovell, *Outline*, 4.

⁷³ *Ibid.*

⁷⁴ *Ibid.*, 4, 22; Coleman, *Humane Society Leaders*, 181. The Women's Branch had asked George Angell, cofounder of the Massachusetts SPCA, who was travelling in Europe, to send them information about the Battersea Home for Friendless Dogs in London and the Dog Hospital in Paris, and they hoped to model their shelter on those institutions. Unti, "Quality of Mercy," 167–168.

⁷⁵ "An Ordinance to Empower the Mayor to Enter into a Contract with Parties for the Taking Up, Killing and Removing of Dogs Found Running At Large in the City," *Ordinances and Joint Resolutions of the City of Philadelphia From January 1st to December 31st, 1871* (Philadelphia, 1872), 55–56.

Part I: The First Era of Sheltering
Chapter 2: Philadelphia: Home of the First Animal Shelter

The Women's Branch built a new facility for their shelter on land that the city provided for the purpose, and hired a pound superintendent, an assistant superintendent, and three dog catchers.⁷⁶ White called it a "shelter" because she planned to run it humanely and wanted to distinguish it from the city dog pound.⁷⁷ It was a "public" shelter because it had the animal control responsibility to capture, house, and dispose of unlicensed dogs for the city. The Women's Branch wanted to do both animal control and animal care because they felt that the only way to be sure that dogs were treated humanely was to get the city pound workers completely out of the picture.⁷⁸ In addition to taking in free roaming dogs, the Women's Branch encouraged owners of unwanted dogs to bring them to the shelter rather than abandoning them.⁷⁹ This would grow into the "owner surrender" function of public shelters, which would often contribute as much or more to shelter intake as impoundment of free roaming dogs.



Figure 8:
The Women's Branch dog shelter in Philadelphia. Photo from the collection of Women's Animal Center, America's First Animal Shelter – formerly known as women's Human Society for the Prevention of Cruelty to Animals.

The shelter had two yards, one for males and one for females, and each dog had its own kennel.⁸⁰ In cold weather, the kennels were supplied with straw, and doors to block the wind.⁸¹ The Women's Branch installed arbors and trellises in the dog yards and trained grape vines over them to provide shade in the summer, and installed troughs so that the dogs always had drinking water.⁸² The dogs also had a tub of water to cool off in during hot weather.⁸³ Dogs were fed daily with meat and corn meal.⁸⁴ Instead of the 24 hour hold period required by law, the shelter usually held dogs for at least three days to make sure that owners had time to reclaim them.⁸⁵ The superintendent, George McCaughlin, was able to handle aggressive dogs by giving them time to adjust and approaching them with "gentle coaxing."⁸⁶

⁷⁶ Lovell, *Outline*, 22–24.

⁷⁷ Unti, "Quality of Mercy," 172; "First Anniversary." The women had initially wanted to call it the "Home for Dogs," but decided to use the term "shelter" due to the ridicule they had already experienced from the press.

⁷⁸ Bernard Unti, "Caroline Earle White," *AV Magazine* 108 (Fall 2000), 7.

⁷⁹ Unti, "Quality of Mercy," 171.

⁸⁰ Lovell, *Outline*, 22.

⁸¹ "Merciful to the Dogs," *Philadelphia Inquirer*, May 24, 1896.

⁸² Lovell, *Outline*, 22.

⁸³ "Merciful to the Dogs."

⁸⁴ Lovell, *Outline*, 22; "Merciful to the Dogs."

⁸⁵ Lovell, *Outline*, 22; "Dogs Doomed to Die: A Chat with the Superintendent of the Pound," *Philadelphia Inquirer*, August 20, 1889.

⁸⁶ "Dogs Doomed to Die"; "Merciful to the Dogs."

Part I: The First Era of Sheltering
Chapter 2: Philadelphia: Home of the First Animal Shelter



Figure 9:

The dog wagon, with ventilation and separate compartments for large and small dogs. Photo from the collection of Women's Animal Center, America's First Animal Shelter – formerly known as Women's Human Society for the Prevention of Cruelty to Animals.

The Women's Branch found new homes for unclaimed dogs who were "in any way valuable or possessed of desirable qualities."⁸⁷

The shelter operated year-round, not just during the summer season.⁸⁸ The dog catchers were given a regular salary rather than the 50 cents per dog paid out under the old system, thus taking away any incentive to steal dogs.⁸⁹ Dog catchers used nets instead of lassoes, and the wagons had shock absorbers and partitions to separate dogs.⁹⁰ The wagon had a body of iron wire for air circulation.⁹¹ An agent usually accompanied the dog catchers to collect redemption fees from people who wanted to pay the fine immediately, rather than having their dogs taken to the shelter.⁹² The New York Herald, which conducted an investigation of dog pounds in 1897, concluded that it would be hard to find a better

facility.⁹³ One commentator called the shelter "a model for the country" that was "not excelled elsewhere."⁹⁴

Although the Women's Branch greatly changed and improved the way free roaming dogs were impounded and housed, they still killed the majority of dogs they took in.⁹⁵ As White noted, city law required that dogs who were running unmuzzled in the streets be killed.⁹⁶ The Women's Branch opposed muzzling, and their stance on the issue led to criticism from the press. Two articles that appeared in the Philadelphia Inquirer in the spring and summer of 1874 accused the Women's Branch of ignoring the danger of rabies.⁹⁷ The articles referred to "maudlin sentiment," "sentimental trifling," and "cheap sentimentality" on the part of the "ladies" running the shelter.⁹⁸ One of the articles applauded the police for shooting unmuzzled dogs in the streets.⁹⁹

City law and the public's fear of rabies may have required that unclaimed dogs be killed, but the Women's Branch sought expert help to make the killing as humane as possible.¹⁰⁰ They used drowning to kill neonatal puppies, since that was considered the most humane method for small and very young animals.¹⁰¹ The women used carbonic acid gas at first to kill the adult dogs, but they were not satisfied with the results and

⁸⁷ "First Anniversary."

⁸⁸ Ibid.

⁸⁹ "Dogs Doomed to Die"; Lovell, *Outline*, 24.

⁹⁰ Lovell, *Outline*, 22; Unti, "Quality of Mercy," 169, 469.

⁹¹ "Quaker City Pounds," *Philadelphia Inquirer*, July 25, 1897.

⁹² "Merciful to the Dogs."

⁹³ "Quaker City Pounds." Despite the improvements in the way the dogs were treated, the dog catchers were still unpopular with some citizens. The *Philadelphia Inquirer* reported that "in some localities showers of sticks and stones are everyday occurrences." "Dogs Doomed to Die."

⁹⁴ Zulma Steele, *Angel in Top Hat* (New York: Harper & Brothers, 1942), 136.

⁹⁵ Lovell, *Outline*, 23.

⁹⁶ Lovell, *Outline*, 22; "An Ordinance to Empower the Mayor."

⁹⁷ "The Police and the Dogs," *Philadelphia Inquirer*, May 14, 1874; "Unmuzzled Dogs in Our Streets," *Philadelphia Inquirer*, July 6, 1874.

⁹⁸ "The Police and the Dogs"; "Unmuzzled Dogs."

⁹⁹ "The Police and the Dogs."

¹⁰⁰ Lovell, *Outline*, 8.

¹⁰¹ Unti, "Quality of Mercy," 176.

Part I: The First Era of Sheltering
Chapter 2: Philadelphia: Home of the First Animal Shelter

within a few years began using carbon monoxide.¹⁰² White reported in 1880 that in an average year the shelter took in around 3,000 dogs, of which about 600 were reclaimed by their owners, 2,300 were killed, and 100 were placed with new owners.¹⁰³

Today, many people think of animal control as designed to protect both people and animals. The ability of state and local governments to regulate stems from the police power to protect citizens, however, and domestic pets are property.¹⁰⁴ Surrendered animals and unclaimed free roaming animals who are impounded by a public shelter generally become the property of the government, and it can be problematic for a government to spend tax dollars on programs for the benefit of animals themselves rather than the public. One advantage of private organizations contracting to run animal sheltering for a city or county, as the Women's Branch did, is that private organizations can use donations from the public to provide care for shelter animals that focuses on their needs and lives rather than on public safety.¹⁰⁵

Because the Women's Branch was a private organization contracted to provide a public service, it was not bound by the financial constraints of a city dog pound. It could use donations to pay for things that were not covered by the city contract, such as humane animal control practices, humane housing, longer holding periods for impounded dogs, adoption efforts, and a painless method of death for the animals it killed. Lovell reported that in 1870 the city of Philadelphia allotted the Women's Branch \$2,500.00 for the dog pound, but the Women's Branch spent "a considerable amount from their own treasury" as well.¹⁰⁶ By 1900, the Women's Branch had held about 40 fairs and other entertainments as fundraisers, and it also received donations and bequests.¹⁰⁷

One example of the advantage of private funds was the ability of the Women's Branch shelter to forgive the city's high reclaim fee (the fee that an owner had to pay to recover an impounded dog).¹⁰⁸ Children were frequently inconsolable when the family dog was impounded, and the Women's Branch would pay the reclaim fee if the parents could not afford it.¹⁰⁹ This policy was not limited to children, and White stated in 1880 that the Women's Branch "invariably" paid the fee for owners who were attached to their dogs but too poor to reclaim them.¹¹⁰ The organization's annual report for 1909 listed 1,223 dogs as "redeemed" and 133 dogs as "given back to their owners."¹¹¹

A problem that the Women's Branch ran into almost immediately upon winning the contract to run the pound was how to prevent vivisectionists from taking unclaimed dogs. Doctors and scientists who did medical experiments on dogs and other animals were called "vivisectors" at that time because they often operated on live animals without anesthesia or with inadequate anesthesia.¹¹² One source of animals for the vivisectors' experiments was city dog pounds. The cruelty of vivisection was an issue for Henry Bergh, the

¹⁰² Lovell, *Outline*, 10; Unti, "Quality of Mercy," 174–175; J. Fred Smithcors, *The Veterinarian in America, 1625–1975* (Santa Barbara, CA: American Veterinary Publications, 1975), 98.

¹⁰³ Lovell, *Outline*, 23.

¹⁰⁴ *Sentell v. New Orleans & Carrollton Railroad Company*, 166 U.S. 898 (1897); Hunter and Brisbin, *Pet Politics*, 55.

¹⁰⁵ Historian Jessica Wang used the dog-pound system in New York City as an example for her discussion of private involvement in public functions in the United States. Wang, "Dogs and the Making of the American State," 998–1024.

¹⁰⁶ Lovell, *Outline*, 5. White later stated that the amount from the city was \$3000. Lovell, *Outline*, 22.

¹⁰⁷ *Ibid.*, 62–63.

¹⁰⁸ Unti, "Quality of Mercy," 492.

¹⁰⁹ Lovell, *Outline*, 38–39; "Dogs Doomed to Die."

¹¹⁰ Lovell, *Outline*, 23.

¹¹¹ Forty-First Annual Report of the Women's Pennsylvania Society for the Prevention of Cruelty to Animals for the Year Ending December 31, 1909 (Philadelphia: Women's Pennsylvania SPCA, 1910): 24.

¹¹² For a discussion of the early fight against vivisection, see Unti, "Quality of Mercy," 615–664.

Part I: The First Era of Sheltering
Chapter 2: Philadelphia: Home of the First Animal Shelter

founder of the ASPCA, who battled vivisectionists in New York City.¹¹³ He fought from 1866 to 1880 to stop vivisection, but finally decided that support for vivisection was so entrenched in New York that it was futile to continue to seek legislative reform on the issue.¹¹⁴

The women in Philadelphia had better luck at stopping vivisectionists from taking animals from the dog pound. Before the Women's Branch took over the pound, the mayors of Philadelphia had allowed doctors and scientists to take pound dogs to use in their experiments.¹¹⁵ When one of the doctors asked White to allow them to continue the practice of taking dogs for vivisection, "an animated correspondence . . . ensued," and she unceremoniously refused his request.¹¹⁶ Her board unanimously backed her up. The vivisectionists attempted to enlist the mayor, the city council, and the men's Pennsylvania SPCA to overturn her decision, but they all supported White.¹¹⁷ The 1871 ordinance that provided for the Women's Branch to operate the shelter under contract further buttressed their position, because it expressly gave the women power over disposition of the dogs.¹¹⁸

Many years later, in 1915, the Women's Branch had to battle the vivisectionists again when a state law was proposed that would have allowed medical schools to have all unclaimed dogs.¹¹⁹ The women did not have much time to react, but they arranged a statewide telegram campaign, and the bill was not even brought up for a vote after a "flood of messages" came in against it.¹²⁰ This victory in preventing shelter animals from being seized by researchers was just a temporary success; however, in what would be an ongoing battle against vivisectionists that would go on across the United States for decades to come.¹²¹

Although the Women's Branch succeeded in stopping the cruelties of the city dog pound, there was still much more that needed to be done. Their new dog shelter was located on the edge of the city, and transportation from the center of the city to the shelter was slow and cumbersome. A downtown facility was needed so that dogs abandoned by their owners could be held in humane conditions until they were transported to the dog shelter. Another problem was that the dog shelter did not accept animals of other species, and the city needed an institution that could care for all sick or injured animals, including cats.¹²²

For most of the 1800s, in most cities, animal control efforts centered on dogs and cats were largely left alone.¹²³ Cats were less likely to call attention to themselves since they did not chase horses or sheep or bite people in the street, and people appreciated them for keeping rodents under control.¹²⁴ Cats were also harder to catch than dogs. Cats faced their own dangers though, including being shot, harassed or killed by boys, or left to fend for themselves when their families moved.¹²⁵

The Women's Branch in the 1870s had members who had been engaged in individual efforts to help cats even before the Women's Branch was formed. One such member was Elizabeth Morris, who had run a

¹¹³ Turner, *Reckoning with the Beast*, 108; Unti, "Quality of Mercy," 330–333.

¹¹⁴ Unti, "Quality of Mercy," 332–333.

¹¹⁵ Lovell, *Outline*, 5–6; Unti, "Quality of Mercy," 334–337.

¹¹⁶ Lovell, *Outline*, 6.

¹¹⁷ Coleman, *Humane Society Leaders*, 204; Unti, "Quality of Mercy," 335–337.

¹¹⁸ "An Ordinance to Empower the Mayor," 55–56.

¹¹⁹ "Dog Pound Measure Meets with Defeat," *Philadelphia Inquirer*, May 20, 1915.

¹²⁰ *Ibid.*

¹²¹ See chapter 7.

¹²² Lovell, *Outline*, 9.

¹²³ Unti, "Quality of Mercy," 502.

¹²⁴ Grier, *Pets in America*, 215–216.

¹²⁵ *Ibid.*, 35–37.

Part I: The First Era of Sheltering
Chapter 2: Philadelphia: Home of the First Animal Shelter

home-based rescue in Philadelphia with a friend, Annie Waln, starting in 1858.¹²⁶ They went out into the streets of Philadelphia to find homeless animals, tried to rehome as many as they could, and killed the rest with chloroform. Kate Covert of Philadelphia also had a home rescue, and she would answer calls about sick and injured animals, including cats, and either nurse them back to health or kill them with chloroform if she thought they were beyond hope.¹²⁷

Elizabeth Morris took on the project of establishing a Women's Branch facility in downtown Philadelphia that would serve as a depot for dogs on their way to the dog shelter, as well as a shelter for cats and other animals in need. This facility was called the City Depot at first, and it opened in 1874.¹²⁸ In its first 11 months of operation, the Depot took in 856 animals, and by 1883, it was taking in close to 10 times that many.¹²⁹ The City Depot was the first known shelter in the world that was open to "any and every species of animal needing shelter."¹³⁰ After a few years, its name was changed to City Refuge for Lost and Suffering Animals.¹³¹ Kate Covert worked with both the Women's Branch shelter and the City Refuge, answering calls about sick and injured animals.¹³² She would go "several miles for a sick cat," and she would tip boys who brought her sick animals.¹³³

In 1888, the Women's Branch and the City Refuge decided to part ways, and a new organization named the Morris Refuge Association for Homeless and Suffering Animals was formed to take over the City Refuge.¹³⁴ The Morris Refuge took in large numbers of cats, almost 18,000 in 1893.¹³⁵ The organization had a wagon that its superintendent could send when he received notice of a sick or injured animal that needed help.¹³⁶ The Morris Refuge still exists today, and has been known as the Morris Animal Refuge since 1907.¹³⁷ In 1963, one commentator noted that for over 80 years the Morris Animal Refuge had operated "nights, Sundays, and holidays" and "its doors have never been closed."¹³⁸

In some cities in the late 1800s, including Boston and Chicago, humane activists formed "animal rescue leagues" which, like the Morris Refuge, took in cats, as well as dogs.¹³⁹ One of the priorities of the animal rescue leagues was to encourage people to turn unwanted animals over to a shelter rather than abandon them.¹⁴⁰ By the early 1900s, these private organizations were an important part of the effort to provide sheltering for homeless cats and dogs.¹⁴¹ As of 1924, there were, by one count, 36 animal rescue leagues.¹⁴²

¹²⁶ Coleman, *Humane Society Leaders*, 208.

¹²⁷ "A Life-Long Friend of Dumb Animals," *Philadelphia Inquirer*, August 30, 1896; "Spent Many Years Killing Animals," *Philadelphia Inquirer*, March 5, 1906.

¹²⁸ Lovell, *Outline*, 9.

¹²⁹ *Ibid.*, 9, 29.

¹³⁰ "An Eden for Dogs," *Philadelphia Inquirer*, April 23, 1899; Lovell, *Outline*, 29.

¹³¹ Lovell, *Outline*, 29.

¹³² "Woman Friend of Animals Dies," *Philadelphia Inquirer*, January 18, 1908.

¹³³ "A Life-Long Friend."

¹³⁴ Lovell, *Outline*, 37; Coleman, *Humane Society Leaders*, 208; Swallow, *Quality of Mercy*, 38–39.

¹³⁵ Unti, "Quality of Mercy," 503.

¹³⁶ Helen Winslow, *Concerning Cats: My Own and Some Others* (Boston: Lothrop, Lee & Shepherd, 1900), 194.

¹³⁷ Swallow, *Quality of Mercy*, 39; "History and Mission," *Morris Animal Refuge*, accessed April 4, 2017, <http://www.morrisanimalrefuge.org/history-mission.html>.

¹³⁸ Swallow, *Quality of Mercy*, 39.

¹³⁹ Coleman, *Humane Society Leaders*, 208–210; Shultz, *Humane Movement in the United States*, 65–66.

¹⁴⁰ Shultz, *Humane Movement in the United States*, 66.

¹⁴¹ McCrea, *Humane Movement*, 87.

¹⁴² Coleman, *Humane Society Leaders*, 209.

Part I: The First Era of Sheltering
Chapter 2: Philadelphia: Home of the First Animal Shelter

By the early 1900s, SPCAs, humane societies, and animal rescue leagues were increasingly taking over city dog pounds in order to run them more humanely, just as the Women's Branch had done.¹⁴³ It is hard to overstate the lasting effect of the Women's Branch takeover of the Philadelphia city pound (and the subsequent formation of the City Refuge) on the care of homeless pets in the United States. One historian of the period called the founding of the Women's Branch shelter in 1870 "the inspiration for virtually all innovation in the field of municipal animal control during the formative decades of organized animal protection."¹⁴⁴ White and the Women's Branch "alter(ed) the course of animal protection in the United States" and established the animal shelter as "a fundamental institution of the humane movement."¹⁴⁵

¹⁴³ McCrea, *Humane Movement*, 87.

¹⁴⁴ Unti, "Caroline Earle White," 7.

¹⁴⁵ Unti, "Quality of Mercy," 149–150.

Chapter 3: New York City: The Politics of Sheltering

Before the Civil War, many cities in the United States used a bounty system for dog control, paying citizens or designated dog catchers a set fee for each free-roaming dog killed or brought to a police station or dog pound. That model began to change after the Civil War, starting with the Women's Branch of the Pennsylvania SPCA taking over dog control for the city of Philadelphia in 1870. The same transition to a public-private partnership happened in New York City, but only after a longer and more complicated course. Dog control was under city management in New York until 1894, and the system became notorious for profiteering.¹

Bounty seasons on dogs in the 19th century were often declared for the summer months, when fear of rabies was high.² In New York City, this practice extended back to the early 1800s, when the mayor advised the police to pay people 50 cents for every unmuzzled dog who was found at large in July or August.³ City residents killed large numbers of dogs in the streets during these bounty seasons. In 1836, for example, citizen bounty hunters killed 8,537 dogs.⁴

Lydia Maria Child, an author, human rights activist, and supporter of humane education, happened to be visiting New York City during a bounty season in 1841.⁵ She wrote that she ran from the window of her hotel room whenever she heard the “dog killers” out in the street, because they were such a “frightful sight, with their bloody clubs, and spattered garments.” The clubs did not always kill the dogs immediately: “Sometimes they are horribly maimed and run howling and limping away.” She did not object to the removal of the dogs, stating that the “safety of the city doubtless requires their expulsion.” Instead, she characterized the manner of the killing as “exceedingly cruel and demoralizing,” and questioned the effect of such sights on young people.



Figure 10:
Lydia Maria Child, circa 1870. Author unknown. Public domain.

The bounty system, in addition to being cruel, provided an incentive for people to steal dogs. This made the owners of valuable dogs very unhappy. In 1845, the Sportsmen's Club asked the city aldermen to revise the dog ordinance to provide that dogs wearing a collar with identification “should be taken by the men appointed to kill Dogs to some Public Yard” so that owners could have a chance to reclaim them.⁶ The

¹ Jessica Wang, “Dogs and the Making of the American State: Voluntary Association, State Power, and the Politics of Animal Control in New York City, 1850–1920,” *Journal of American History* 98, no. 4 (March 2012): 1005–1006, doi:10.1093/jahist/jar566.

² Asa Greene, *A Glance At New York: Embracing the City Government, Theatres, Hotels, Churches, Mobs, Monopolies, Learned Professions, Newspapers, Rogues, Dandies, Fires and Firemen, Water and Other Liquids, &c., &c.* (New York, 1937), 85–86.

³ “City Dogs,” *New York Times*, July 26, 1857.

⁴ Greene, *A Glance At New York*, 87.

⁵ Lydia Maria Child, *Letters from New-York: A Portrait of New York on the Cusp of its Transformation into a Modern City*, ed. Bruce Mills (Athens: University of Georgia Press, 1998), 15.

⁶ Proceedings of the Board of Assistant Aldermen, from May 13th to November 10th, 1845 (New York, 1846), 63

sportsmen pointed out that the existing ordinance led to “the unnecessary sacrifice of many valuable Dogs”

The Sportsmen’s Club proposal was not acted on immediately, but several years later, in 1851, the city did establish a dog pound that was open for the summer months.⁷ Valuable dogs were kept for two or three days, but the others were killed at the end of the day they were impounded unless reclaimed by their owners.⁸ The dogs were reportedly not fed or given water while awaiting their fate.⁹

The pound was moved from one location to another almost every summer in its early years because the noise and the crowds of people it attracted made it an unpopular neighbor.¹⁰ Nevertheless, public sentiment seems to have been in favor of maintaining a pound. As one commentator put it, the pound “rids the City of the nuisance of the living agents of hydrophobia.”¹¹ Another said, on seeing the dogs at the pound in 1856: “The first impression while viewing them is one of regret that so many animals should be slaughtered; but the first thought of hydrophobia, and that impression vanishes.”¹² In the first six years of its existence, the pound received over 22,000 dogs, with the number increasing each year.¹³

The city continued to pay people to catch unmuzzled dogs under the pound system, but bounty seekers had to bring the dogs to the pound alive rather than killing them in the street.¹⁴ This did not solve the problem of dog stealing. Boys from poor and working class families¹⁵ would lure dogs out of their owners’ yards, pull boards off fences to steal dogs, or even breed puppies for the purpose of taking them to the pound and claiming the bounty.¹⁶ Sometimes bounty hunters would take the muzzle off of a dog in order to have an excuse to take the dog to the pound and collect the bounty.¹⁷ Groups of boys would gather near the pound waiting for other boys to come along with their canine captives, whereupon the waiting boys would take the dogs away by force and turn them in for the bounty.¹⁸ The pound’s policemen put a stop to this by allowing the victimized boys to wait at the pound for the robbers to appear with the dogs, at which time the robbers got a lecture and the victims got the bounty fee.

People concerned about the welfare of children thought that the bounty system corrupted the young men of the city, and people who wanted to reform city government criticized the bounty system as promoting criminal activity.¹⁹ The city tried various ways to improve the system. One method was to pay for dogs by check instead of cash, but this merely encouraged adult middlemen to pay the boys a low fee in immediate cash for each dog and then take the dogs to the pound themselves.²⁰ If a dog was valuable, the middleman

⁷ “City Dogs.” The dog pound was reportedly preceded by the establishment of a Dog Bureau in 1850 made up of thirty city-employed dog catchers and a supervisor. They carried clubs and patrolled the streets, killing any “badly-behaved” dogs.

⁸ *Ibid.*

⁹ “Things I Have Seen in Gotham,” *New York Times*, September 15, 1853.

¹⁰ *Ibid.*; “The Dog Pound,” *New York Times*, June 2, 1855; “City Dogs.”

¹¹ “Reforms and the Pound.”

¹² “An Hour at the Dog Pound,” *New York Times*, August 5, 1856.

¹³ “City Dogs.”

¹⁴ “That Dog Pound—Onslaught on the Canines,” *New York Times*, June 26, 1855.

¹⁵ The newspapers often referred to these boys as “urchins.” One article in the *New York Times* in 1857 described them as “[s]mart, shoeless urchins.” “City Dogs.” Another described them as “tattered urchins” and “ragged boys.” “Reforms and the Pound.”

¹⁶ “Reforms and the Pound;” Alvin Harlow, *Henry Bergh: Founder of the A.S.P.C.A.* (New York: Julian Messner, 1957), 121–122; “Things I Have Seen in Gotham;” “The Dog Market,” *New York Times*, July 20, 1855; “The Dog Pound, and the Fate of its Inhabitants,” *New York Times*, October 9, 1857; “Canine Matters,” *New York Times*, June 7, 1860.

¹⁷ “City Dogs.”

¹⁸ “An Hour at the Dog Pound.”

¹⁹ Wang, “Dogs and the Making of the American State,” 1003–1006.

²⁰ “City Dogs.”

would sell it instead of taking it to the pound.²¹ This meant that if a boy stole a valuable dog and turned it over to a middleman, the owner would have little chance of recovering the dog.

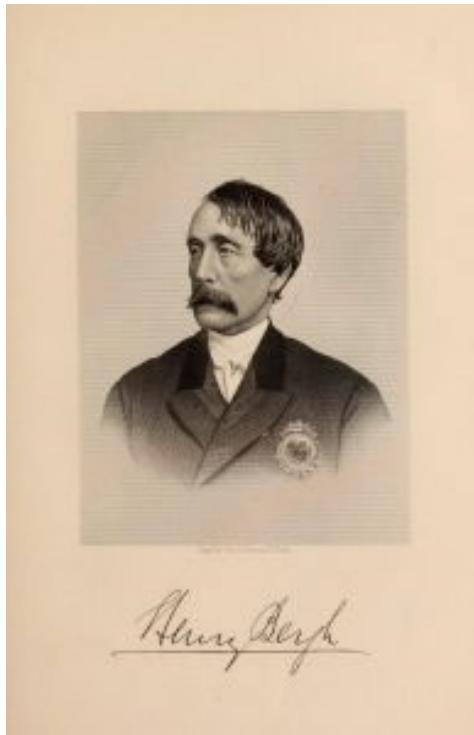

Figure 11:
Henry Bergh, founder of the ASPCA. Engraving by
George E. Perine, published in "History of New York City"
by Benson John Lossing, 1884. Public domain.

In 1858, the city issued a rule that boys could not collect a bounty.²² This merely helped the adult middlemen gain more control over the business and take a bigger cut of the money. In 1860, the city combined a ban on paying bounties to boys with a reduction of the bounty from 50 cents to 25 cents.²³ This resulted in the number of impounded dogs dropping substantially, an unacceptable outcome for those who were concerned about rabies.²⁴

Bounty hunters were not the only corrupt part of the city's dog pound system. A running joke about the dog pound was that the pound master did a booming business in owners having to redeem the same dogs over and over.²⁵ And in 1855, a scandal erupted that kept city residents entertained for months, as various officials alleged and denied that money was being siphoned from dog pound receipts.²⁶

The pound got dog killing off the streets, but did not solve the problem of stray dogs. A reporter counted 10 free roaming, unmuzzled dogs in a six-block walk in New York City in June of 1854.²⁷ In 1856, a journalist wrote that dogs in Brooklyn "swarm in all the streets, obstruct the pavements, [and] make night hideous with their howls."²⁸ This journalist counted 27 unmuzzled dogs in a walk of about 1/3 of a mile.

An aspect of the New York City pound system that received much publicity was the practice of killing dogs by drowning. In the pound's early years, dogs were drowned in a reservoir or cistern, or on a barge with a tank.²⁹ The pound master could drown dozens of dogs at a time by these methods. The aldermen of Detroit may have been influenced by the New York City system when they adopted a resolution in 1860 to establish a pound that would kill dogs by drowning them in a "tank or vat."³⁰ The Detroit resolution also barred distribution of poisoned meat by people "heretofore employed in the extermination of dogs or other animals."

New York City's cruel and corrupt dog pound system was in place when Henry Bergh founded the ASPCA in 1866. Bergh was one of the three great leaders of the post-Civil War humane movement in the United States, along with Caroline Earle White of Philadelphia and George Angell of Boston. He

²¹ "About the Dog-Pound in the Dog-Days," *New York Times*, July 26, 1860; "The Dog Pound," *New York Times*, July 10, 1874.

²² "City Items," *New York Times*, June 2, 1858.

²³ "About the Dog-Pound."

²⁴ "Canine Matters."

²⁵ "Reforms and the Pound"; "A Distressed Widow Visits an Up-town Institution," *New York Times*, Aug. 13, 1855.

²⁶ "The Police Investigation," *New York Times*, April 18, 1855; "The Dog Pound Controversy," *New York Times*, May 22, 1855; "That Dog Pound"; "Briggs—A Glorious Trinity of Martyrs," *New York Times*, Sept. 8, 1855.

²⁷ "Reforms and the Pound," *New York Daily Times*, June 30, 1854.

²⁸ "Dogs Rampant: To the Rescue," *New York Times*, July 11, 1856.

²⁹ "That Dog Pound"; "Canine Matters;" Zulma Steele, *Angel in Top Hat* (New York: Harper & Brothers, 1942), 128.

³⁰ Journal of the Proceedings of the Common Council of the City of Detroit, January 10, 1860, to January 8, 1861, Inclusive (Detroit, 1861), 154.

Part I: The First Era of Sheltering
Chapter 3: New York City: The Politics of Sheltering

accomplished many things in his career, including spearheading the passage of a broad anti-cruelty law in New York State,³¹ supporting the establishment of a society to protect children,³² assisting with the formation of other SPCAs, and enforcing better conditions for horses and meat animals. Bergh also worked to stop dog fighting and overworking of dogs used for turning spits and pulling carts.³³

Homeless dogs and cats were initially a minor concern for most of the SPCAs formed after the Civil War, but Bergh nevertheless took an interest in the New York City dog pound. He successfully lobbied the mayor in 1868 to reduce the bounty to 25 cents and ban young people from turning dogs in at the pound, repeating what had been done in 1860.³⁴ Once again, as in 1860, this resulted in a sharp drop in the number of dogs impounded.³⁵ The following year there was a battle between the mayor and the Board of Health over who should control the dog pound, with the result that the pound did not open at all.³⁶

Bergh knew Caroline Earle White, since she had consulted with him before founding the Pennsylvania SPCA in 1867.³⁷ In 1870, Bergh was a featured speaker at the first annual meeting of the Women's Branch of the Pennsylvania SPCA, which White had founded in 1869, and he congratulated the women on their accomplishments.³⁸ White spoke at that meeting about the women's contract to do dog control in Philadelphia and their plan to build a humane shelter. This idea appealed to Bergh, and in 1871, he made an unsuccessful attempt to get New York City to build a shelter for impounded dogs along the lines of the Women's Branch shelter.³⁹

Bergh tried again in 1873, sending a letter to the New York City mayor stating that the ASPCA would "willingly undertake" to capture free roaming dogs and kill the "valueless" unclaimed ones using carbonic acid gas, if the city would provide a building to be used for humane impoundment and reimburse the ASPCA for its actual costs.⁴⁰ Bergh proposed that scoop nets be used by dog catchers and that the ASPCA ambulance follow the dog catchers.⁴¹ The suggestion was referred to



Figure 12:
Entrance to the ASPCA in Bergh's time. Artist unknown. From C. C. Buel, "Henry Bergh and His Work," published in Scribner's Monthly 17: 872-84. Public domain.

³¹ Bergh succeeded in pushing through an amendment to New York State's existing anti-cruelty statute within a few days after the ASPCA was formed in 1866. He then successfully worked to pass an expanded anti-cruelty law the following year. David Favre and Vivien Tsang, "The Development of Anti-Cruelty Laws During the 1800s," *Detroit College of Law Review* (Spring 1993): 14–18, <http://digitalcommons.law.msu.edu/cgi/viewcontent.cgi?article=1146&context=facpubs>.

³² Sydney Coleman, *Humane Society Leaders in America* (Albany: American Humane Association, 1924), 71–76; Eric Shelman and Stephen Lazortz, *The Mary Ellen Wilson Child Abuse Case and the Beginning of Children's Rights in 19th Century America* (Jefferson, NC: McFarland, 2005).

³³ Harlow, *Henry Bergh*, 119–120; Steele, *Angel in Top Hat*, 126–27.

³⁴ "The Society for the Prevention of Cruelty to Animals," *New York Herald*, July 21, 1869.

³⁵ *Ibid.*; "Hydrophobia," *New York Herald*, May 24, 1869.

³⁶ "Enforcement of the Dog Law," *New York Times*, June 20, 1869; Steele, *Angel in Top Hat*, 130–131.

³⁷ Mary Lovell, "Mrs. Caroline Earle White: A Retrospect," *Journal of Zoöphily* 25, no. 9 (September 1916), 131; Jane Campbell, "Mrs. Caroline Earle White, Reformer," in *Records of the American Catholic Historical Society of Philadelphia, Volume 33* (Philadelphia: American Catholic Historical Society of Philadelphia, 1922), 37–38.

³⁸ "First Anniversary of the W. B. O. T. S. F. T. P. O. C. T. A.," *Philadelphia Inquirer*, April 7, 1870.

³⁹ "The Philadelphia Dog Shelter," *New York Times*, August 25, 1871.

⁴⁰ "A Dog's Home and Shelter," *New York Times*, April 7, 1873; "Destruction of Dogs in Philadelphia," *New York Times*, July 11, 1874; Harlow, *Henry Bergh*, 124; Steele, *Angel in Top Hat*, 136.

⁴¹ "A Dog's Home and Shelter."

the city's Committee on Public Works, which responded that it did not have any money appropriated to fund such a plan.⁴²

In 1874, the aldermen of New York, perhaps in response to Bergh's 1873 proposal, asked the ASPCA to take over the existing city pound and operate it under the bounty system.⁴³ The ASPCA would keep the fines paid for reclaimed dogs, and pay the 50 cent bounty from a city contingency fund.⁴⁴ Bergh declined on the grounds that he did not want to perpetuate the cruelty of the existing system and did not want to reward young men for stealing and mistreating animals.⁴⁵ The bounty system was not part of the Philadelphia model that he admired and wanted New York City to adopt.

After the rebuff by Bergh, the city decided to try to improve the dog pound system on its own, with disastrous results. The ordinance for the summer dog catching season in 1874 dispensed with the system of paying a bounty to anyone who brought in a dog. Instead, the mayor appointed licensed dog catchers for each election district, and directed that only the official dog catchers could collect the bounty.⁴⁶ One journalist referred to this plan as licensing dog thieves, and asked if the mayor was planning to license burglars as well.⁴⁷ The journalist was correct in foreseeing that the appointment of official dog catchers who were paid per dog would not stop the practice of dog stealing, and several stories were published that summer about the misdeeds of the new officials. One dishonest practice involved dog catchers taking dogs from under their owners' noses and then collecting the redemption fee on the spot and pocketing it.⁴⁸

Outrages by the appointed dog catchers continued for years and were periodically featured in the newspapers. A particularly egregious example of dog stealing occurred in 1880, when a deputy dog catcher was arrested for "snatching a dog from the arms of a little girl."⁴⁹ In an 1883 case, a dog stolen by a dog catcher mysteriously turned up at a saloon after his owner raised a fuss and the mayor demanded the return of the dog.⁵⁰ In 1892, a citizen wrote to the newspaper to report a case of dog catchers who overpowered a man and his friend and threw the man's dog into their truck before driving away.⁵¹ An 1893 article described how two dog catchers snuck up behind an elderly woman and grabbed her leashed dog, carrying it off and leaving her crying.⁵² That same article reported an incident of a valuable dog who saw the dog catchers coming and ran up to his front door. His owner, who was watching him, let him inside and closed the door, but the dog catchers came up the steps and tried to force the door in. They were finally driven away by a policeman.

The 1874 ordinance to improve the pound by licensing dog catchers failed to wipe out dog stealing, but an even more egregious failure was the city's disastrous attempt that same year to improve the method for killing the dogs. City officials announced a switch from drowning dogs to using carbonic acid gas.⁵³ When the new system was tried, the tank used to gas the dogs leaked and some dogs were still alive even after

⁴² "Common Council," *New York Times*, May 2, 1873; Harlow, *Henry Bergh*, 124; Steele, *Angel in Top Hat*, 136.

⁴³ Harlow, *Henry Bergh*, 122; Steele, *Angel in Top Hat*, 131.

⁴⁴ Steele, *Angel in Top Hat*, 131.

⁴⁵ Harlow, *Henry Bergh*, 122; Steele, *Angel in Top Hat*, 131.

⁴⁶ "Board of Assistant Aldermen," *New York Times*, June 30, 1874; "Our New Officials," *New York Times*, July 26, 1874; "The Dog Pound," *New York Times*, July 17, 1874.

⁴⁷ "Our New Officials."

⁴⁸ "Charge Against an Official Dog-Catcher," *New York Times*, July 24, 1874; "Another Delinquent Dog-Catcher," *New York Times*, September 3, 1874.

⁴⁹ "City and Suburban News—New York," *New York Times*, July 15, 1880.

⁵⁰ "Dog-Catcher Donohue's Little Game," *New York Times*, July 24, 1883.

⁵¹ "The City's Dog Catchers: They Steal Dogs Walking Quietly with Their Owners," *New York Times*, June 12, 1892.

⁵² "Dog Catchers Are Now Alert," *New York Times*, May 13, 1893.

⁵³ "Opening of the Dog Pound," *New York Times*, June 12, 1874.

Part I: The First Era of Sheltering
Chapter 3: New York City: The Politics of Sheltering

two hours in the contrivance.⁵⁴ The pound master finally pulled the surviving dogs out and they were shot or clubbed to death. It was such a debacle that Bergh had the pound master arrested for cruelty.⁵⁵ The tank was deemed suitable for use after it was lined with zinc,⁵⁶ but the gassing method had sustained considerable damage to its credibility.

In 1877, New York City built a new pound, with 300 stalls for dogs, next to a dock on the East River.⁵⁷ The ASPCA had succeeded by that time in persuading the city to hold all dogs for 48 hours, give them food and water twice a day, and sell valuable dogs to fanciers rather than killing them.⁵⁸ The new pound used drowning as the method of killing, but dogs were drowned in the river instead of in a tank inside the pound. This was accomplished with a large iron cage, reportedly 7' long, 4' high, and 5' wide, which could be stuffed with almost 50 dogs at a time.⁵⁹ The empty cage was rolled into the pound and dogs were dropped into it through an opening in the top. The cage was then rolled out onto the dock, where it was attached to a crane, raised up, swung out, and lowered into the river. Dog pound workers used "clubs in case of escape from the water."⁶⁰ Although drowning is often thought of as one of the less painful ways to die, it was certainly a cruel death for a mass of struggling dogs to be forced into a cage and drowned together, especially when the cage sometimes had to be lowered into the river two or three times to kill all the dogs.⁶¹

The *New York Times* published a graphic account of the killing procedure on the first day the drowning crate was used at the new pound.⁶² The newspaper reported that 762 dogs and puppies were drowned that day. Only 20 dogs were thought to be valuable enough to be held back. The outlook of the reporter is interesting. Although he acknowledged that many of the dogs seemed to know they were going to be killed, he faulted them for resisting going into the cage. He described a mother dog who tried to protect her eight puppies by pushing other dogs away from their corner in the cage. But instead of showing sympathy for her terror and admiration for her attempts to protect her puppies, he merely said that she caused great difficulty to the dog catchers by her resistance to going into the cage. He described all the dogs as being "of the very meanest kind," and showed more sympathy for the dog catchers who were bitten than for the dogs who were killed. The dog catchers certainly suffered, as many of them had multiple bites and one had to be hospitalized. The article described "great crowds" watching the drowning.

During the next five years, this method was used to drown 47,000 dogs at the pound.⁶³ In 1888, the mayor of New York asked the Health Department and the ASPCA to investigate whether a more humane method could be found.⁶⁴ Electrocutation and carbon-monoxide gas were rejected as too expensive, and in 1889 chloroform was selected as the new method for killing the dogs.⁶⁵

In 1894, six years after Henry Bergh died, the changes that he had wanted for the city's animal control system finally came about. Public pressure and lobbying by Bergh's successor, John Haines, convinced

⁵⁴ "A Disgusting Butchery," *New York Times*, June 28, 1874.

⁵⁵ "Arrest of the Dog Suffocater," *New York Times*, June 21, 1874; "The Dog Pound," *New York Times*, June 25, 1874; "The Persecuted Dogs," *New York Times*, June 22, 1874.

⁵⁶ "The Dog Pound," *New York Times*, July 17, 1874.

⁵⁷ "Destroying the Dogs," *New York Times*, July 6, 1877; Steele, *Angel in Top Hat*, 132–133.

⁵⁸ "Destroying the Dogs."

⁵⁹ *Ibid.*

⁶⁰ Roswell McCrea, *The Humane Movement: A Descriptive Survey* (New York: Columbia University Press, 1910), 87.

⁶¹ Harlow, *Henry Bergh*, 123–124; Steele, *Angel in Top Hat*, 133.

⁶² "Destroying the Dogs."

⁶³ J. Fred Smithcors, *The Veterinarian in America, 1625–1975* (Santa Barbara, CA: American Veterinary Publications, 1975), 98.

⁶⁴ "Death Penalty for Dogs," *New York Times*, October 21, 1888.

⁶⁵ Marion Lane and Stephen Zawistowski, *Heritage of Care: The American Society for the Prevention of Cruelty to Animals* (Westport, CT: Praeger, 2008), 32; "Death Penalty for Dogs"; "Protecting the Animals," *New York Times*, January 7, 1889.

Part I: The First Era of Sheltering
Chapter 3: New York City: The Politics of Sheltering

the state legislature to appoint the ASPCA to license dogs and do animal control for both cats and dogs in New York City.⁶⁶ The city shut down its pound, and the ASPCA built a new facility and hired its own dog catchers.⁶⁷ They were paid a salary without regard to how many dogs they impounded, and stealing dogs for the bounty thus finally came to an end in New York City.⁶⁸ Haines promised that the people of the city would no longer read complaints in the newspaper about the brutality of dog catchers.⁶⁹ In 1895, the legislature amended the law to provide the ASPCA with the authority to do animal control in Brooklyn as well.⁷⁰

Conditions for impounded animals quickly improved after the ASPCA takeover. The new facility had clean kennels, good food and water, and medical care for the animals.⁷¹ One commentator described the dogs taken in as mostly “street outcasts, without homes and without the prospect of obtaining such,” with many being “diseased past recovery.”⁷² Haines said that the ASPCA would try to find homes for unclaimed animals and would kill only the “worthless” ones, using a gas chamber.⁷³ The ASPCA used a chloroform chamber at first, but eventually changed to “illuminating gas,” a mixture of several types of gasses including carbon monoxide.⁷⁴

The ASPCA’s duty under the 1894 law to impound cats, as well as dogs, marked a major change in the city’s approach to animal control. Cats in New York City had received much less attention from local authorities than dogs, even though complaints about cats were common. Newspapers contained frequent references to people being kept awake at night by the howling of cats.⁷⁵ There was no air conditioning in those days, and people could not simply shut their windows in the summer to keep out the noise.

The problem of stray cats had been discussed by the city and the ASPCA for years before the 1894 law was passed, and in the 1880s, Henry Bergh was at the center of those discussions. Bergh had once ordered the newly constructed front of a building taken down because a cat had gotten trapped in the wall.⁷⁶ That made it all the more puzzling when in 1880 he proposed a draconian cat ordinance that provided that all cats found at large in any public place in the city limits should be seized and killed.⁷⁷

The proposed ordinance would have allowed only three hours for owners to reclaim their cats before they were killed.⁷⁸ In a July 21, 1880 note to the president of the city’s Board of Aldermen, Bergh asked for approval of the ordinance “for the sake of suffering humanity as well as the wretched cats.”⁷⁹

Bergh’s proposed cat ordinance was criticized by humane advocates in both Boston and Philadelphia who were concerned that cat owners would not have time to reclaim their pets.⁸⁰ The New York City aldermen

⁶⁶ “The New Dog Law,” *New York Times*, April 29, 1894; “To Catch Dogs Politely,” *New York Times*, March 11, 1894; Wang, “Dogs and the Making of the American State,” 1007.

⁶⁷ Wang, “Dogs and the Making of the American State,” 1007; Lane and Zawistowski, *Heritage of Care*, 31.

⁶⁸ Lane and Zawistowski, *Heritage of Care*, 31.

⁶⁹ “To Catch Dogs Politely.”

⁷⁰ Lane and Zawistowski, *Heritage of Care*, 31–32.

⁷¹ McCrea, *Humane Movement*, 87.

⁷² *Ibid.*, 87–88.

⁷³ “To Catch Dogs Politely.”

⁷⁴ McCrea, *Humane Movement*, 88; Lane and Zawistowski, *Heritage of Care*, 32.

⁷⁵ See, e.g., “Yorkville Thomas Cats: Where Felines Meet and Sing,” *New York Times*, June 23, 1878.

⁷⁶ Harlow, *Henry Bergh*, 118–119; Bernard Unti, “The Quality of Mercy: Organized Animal Protection in the United States, 1866–1930” (PhD diss., American University, 2002), 500.

⁷⁷ Unti, “Quality of Mercy,” 501–502; “The Feline Race,” *New York Times*, July 22, 1880.

⁷⁸ Unti, “Quality of Mercy,” 501–502.

⁷⁹ “The Feline Race.”

⁸⁰ Unti, “Quality of Mercy,” 501–502.

Part I: The First Era of Sheltering
Chapter 3: New York City: The Politics of Sheltering

passed the ordinance,⁸¹ but it did not go into effect, apparently because the mayor refused to sign it.⁸² The mayor's refusal was reportedly due to a lack of funds for the project.⁸³

In the absence of any organized method of dealing with sick and injured cats, some citizens took on the job themselves. A group of women in Brooklyn who called themselves the "Midnight Band of Mercy" made it a practice in the late 1800s to catch free roaming cats that they believed were suffering and kill them with chloroform.⁸⁴ One of their number, Sarah Edwards, was arrested in 1893 and charged with killing cats and throwing their bodies in the street.⁸⁵ This became an occasion for several gleeful articles by reporters, who appeared to think both the actions of the women who killed the cats and the people who opposed them were risible. One of the reporters wrote an article titled "Cats and Old Maids."⁸⁶ Edwards was convicted, and the ASPCA warned that anyone caught chloroforming cats would be prosecuted.⁸⁷ Ironically, it was the following year that the ASPCA began to impound cats.⁸⁸ In 1895, just two years after Edwards was convicted, the ASPCA impounded and killed 23,000 cats, a number that would soar in future years.⁸⁹

For decades to come, the kill rate for cats and dogs at the ASPCA shelter would be extremely high.⁹⁰ During this time, the number of dogs and cats taken in by the ASPCA each year was astonishing by today's standards. In 1914, for example, the ASPCA took in 59,355 dogs and 177,234 cats, of which 88.0% and 99.6%, respectively, were killed.⁹¹ The ASPCA's cat intake reached almost 220,000 in the year 1934, with 99.5% killed.⁹²

The Department of Health in New York City was not satisfied with even this high rate of impounding and killing dogs, and made repeated attempts to take regulation of dogs away from the ASPCA.⁹³ The city's health department was part of a wave of public health reform that sought to get animals of all types off the city streets. The growing influence of public health departments kept the pressure on for cities to impound and kill homeless dogs and cats.⁹⁴

One of the New York City Department of Health initiatives was a June 1908 shoot-to-kill order directing the police to kill all unleashed, unmuzzled dogs on sight.⁹⁵ The directive sparked a public backlash following publicity about pet killings, and the city decided to allow the directive to expire in October. Although the ASPCA and the Department of Health eventually worked out an uneasy coexistence, this battle is an example of the dilemma that the ASPCA and other humane organizations of the era faced in dealing with homeless pets. If the humane organizations had simply refused to kill animals, it seems very likely that the cities would have gone back to doing the job themselves, far less humanely.

⁸¹ "Suppressing the Cats—Mr. Bergh's Ordinance Passed by the Board of Aldermen," *New York Times*, August 4, 1880.

⁸² "The Cat Ordinance," *Evening Star*, August 27, 1880; "City and Suburban News," *New York Times*, August 27, 1880.

⁸³ "The Proposed Cat Ordinance," *New York Times*, July 23, 1880; "City and Suburban News," *New York Times*, August 27, 1880.

⁸⁴ "Miao! Eow! Spat! No More," *New York Times*, June 30, 1893.

⁸⁵ "Her Work Not Appreciated," *New York Times*, October 6, 1893; "Mrs. Edwards Means to Fight," *New York Times*, October 7, 1893.

⁸⁶ "Cats and Old Maids," *New York Times*, July 23, 1893.

⁸⁷ "Cats Lives Are Protected," *New York Times*, November 21, 1893.

⁸⁸ "To Catch Dogs Politely."

⁸⁹ Stephen Zawistowski et al., "Population Dynamics, Overpopulation, and the Welfare of Companion Animals: New Insights on Old and New Data," *Journal of Applied Animal Welfare Science* 1, no. 3 (1998): 202, table 4, doi:10.1207/s15327604jaws0103_1.

⁹⁰ *Ibid.*

⁹¹ *Ibid.*

⁹² *Ibid.*

⁹³ Wang, "Dogs and the Making of the American State," 1012–1017.

⁹⁴ *Ibid.*, 1010.

⁹⁵ *Ibid.*, 1014–1015.

The movement to protect wild birds, which began in the United States by the 1880s, became something of a threat to cats. Efforts to protect birds had initially concentrated on trying to reduce depredations by humans, who killed large numbers of birds for feathers and food.⁹⁶ The number of birds killed for feathers used for trimming hats, for example, led to a “startling decrease” in the population of wild birds.⁹⁷ Conservation and animal advocacy groups campaigned for laws to protect birds, and a boycott of feathered hats soon made them unfashionable.⁹⁸ As the threat to birds from milliners died out though, some bird advocates began to focus on cats.

In 1916, the Massachusetts State Board of Agriculture published a bulletin by Edward Forbush, the state ornithologist, discussing the effect of cats on wildlife.⁹⁹ Forbush pictured the cat as a hyper-efficient killer, stating: “No animal that it can reach and master is safe from its ravenous clutches.”¹⁰⁰ He made an economic argument that since birds eat insects, the killing of birds by cats resulted in more insects, which cost people money for crops destroyed by the insects.¹⁰¹ He acknowledged that cats could be useful to control rodent populations in buildings, but opined that free-roaming cats were overall a “serious detriment to the agriculturalist.”¹⁰²



Figure 13:
The preserved body of Martha, the lost passenger pigeon. Public domain.

Forbush recommended confining owned cats indoors, arguing that cats allowed outdoors were “beyond control, except by means of a shotgun or rifle.”¹⁰³ He stated that cats have “two to four broods yearly, with from five to nine in each brood,” which produced a “necessity for checking such increase promptly by killing all superfluous kittens soon after birth.”¹⁰⁴ A study published in 2004 in the *Journal of the American Veterinary Medical Association* reported, by contrast, that free roaming female cats have a mean of 1.4 litters per year with a median of three kittens per litter, and that 75% of the kittens of free roaming mothers died or disappeared by six months of age.¹⁰⁵

Ironically, it was in 1914, only two years before Forbush singled out cats as being the great destroyer of wild birds, that the last passenger pigeon died. Passenger pigeons were so numerous in North America in the mid-1800s that their flocks could take hours to pass overhead.¹⁰⁶ The rapid extinction of the passenger pigeon is thought to have been due to people killing the birds for meat and clearing land

for farming.

⁹⁶ McCrea, *Humane Movement*, 247–250.

⁹⁷ *Ibid.*, 130.

⁹⁸ Diane Beers, *For the Prevention of Cruelty: The History and Legacy of Animal Rights Activism in the United States* (Athens: Ohio University Press/Swallow Press, 2006), 84–86.

⁹⁹ Edward Forbush, *The Domestic Cat—Bird Killer, Mouser and Destroyer of Wildlife—Means of Utilizing and Controlling It* (Boston: Wright & Potter, 1916).

¹⁰⁰ *Ibid.*, 7.

¹⁰¹ *Ibid.*, 76–80.

¹⁰² *Ibid.*, 81.

¹⁰³ *Ibid.*, 87.

¹⁰⁴ *Ibid.*, 19.

¹⁰⁵ Felicia Nutter, Jay Levine, and Michael Stoskopf, “Reproductive Capacity of Free-Roaming Domestic Cats and Kitten Survival Rate” *Journal of the American Veterinary Medical Association* 225, no. 9 (November 1, 2004): 1399–1402, doi:10.2460/javma.2004.225.1399.

¹⁰⁶ “‘Martha,’ the Last Passenger Pigeon,” *Smithsonian*, accessed April 6, 2017, https://naturalhistory.si.edu/onehundredyears/featured_objects/martha2.html.

Part I: The First Era of Sheltering
Chapter 3: New York City: The Politics of Sheltering

Public health officials and bird conservationists would have preferred that cats, if kept at all, be kept indoors, but it did not become common for people to keep cats exclusively indoors until the last decades of the 20th century. Cats, like dogs, had fleas in the years before flea control was a matter of routine healthcare for pets.¹⁰⁷ And although people used litter boxes for cats as far back as the 1800s (often a box or an enameled pan filled with sand, ash, sawdust, or torn newspaper),¹⁰⁸ modern cat litter was not available until after World War II.¹⁰⁹

New York City was not alone in having large numbers of outdoor cats. Humane organizations in Philadelphia and Boston were also engaged by 1900 in rounding up and killing free roaming cats.¹¹⁰ We do not have any reliable data about cat populations in cities in the period from 1870 to 1920, but the perception was that their numbers were high, and possibly increasing.¹¹¹ That impression was certainly borne out by the number of cats impounded by the ASPCA, which did not level off and begin to decline until around 1930.¹¹²

¹⁰⁷ Katherine Grier, *Pets in America: A History* (Chapel Hill: University of North Carolina Press, 2006), 60.

¹⁰⁸ Ida Mellen, *A Practical Cat Book* (New York: Charles Scribner's Sons, 1939), 118; "The History of Cat Litter and Litter Boxes," *Cat Wisdom 101*, accessed March 6, 2017, <http://catwisdom101.com/history-cat-litter-litter-boxes/>.

¹⁰⁹ Paul Ford, "The Birth of Kitty Litter," *Bloomberg*, accessed March 6, 2017, <http://www.bloomberg.com/bw/articles/2014-12-04/kitty-litters-invention-spawned-pet-cat-industry>.

¹¹⁰ See chapters 2 and 4.

¹¹¹ Grier, *Pets in America*, 216.

¹¹² Zawistowski et al., "Population Dynamics," 202, table 4.

Chapter 4: Boston: A Different Approach

Animal control in Boston, the third of the three leading cities of the post-Civil War humane movement, developed more slowly than in Philadelphia and New York. In fact, the city did not even hire an official dog catcher until 1877.¹ George Angell, who along with Emily Appleton, founded the Massachusetts SPCA in Boston in 1868,² believed that Boston had very few free roaming dogs compared with other cities and therefore had little need for dog catchers.³ The impetus for Boston to finally implement a more formal dog control system in 1877 was an 1876 rabies outbreak that killed 44 people before it subsided by 1881.⁴

Boston's first official dog catcher was veterinarian Albert "Al" Watts.⁵ Watts, a show dog fancier who had written a book about canines, was head dog catcher until 1889.⁶ In the summertime, he and his assistants went out on daily rounds to capture unlicensed dogs.⁷ They were paid a fee by the city for each dog they caught, but there was no bounty system to pay civilians to catch dogs. Watts used a poison given orally in powder form to kill the dogs. He believed this was a humane method because the dogs died in 30 seconds or less after administration of the poison.⁸ Dogs that Watts judged to be mongrels were killed at the end of the day they were captured, while purebreds were held for a few days to allow their owners to reclaim them.⁹

Like the staff at the Women's Branch shelter in Philadelphia, Watts sometimes returned dogs without charge to owners who could not pay the fines. A newspaper article from 1885 reported how a homeless man with tears streaming down his face begged Watts to release his dog instead of taking him to the pound, saying that the dog was his only friend and he would die if the dog was taken away.¹⁰ Watts released the dog and gave the man a silver coin. Watts' successor, Dr. Schenck (another veterinarian), "often paid the fee from his own pocket" for children's pet dogs when the parents could not afford a license.¹¹

Schenck believed that cats were more of a nuisance in Boston than dogs.¹² City authorities took no action as to cats, however, and eventually a private humane organization stepped in. Anna Harris Smith founded the Animal Rescue League of Boston (ARL) in 1899, and one of the first items on its agenda was to capture homeless cats and kill them with chloroform.¹³ The ARL was modeled on Philadelphia's Morris Refuge

¹ "Catching Characterless Canines," *Boston Daily Globe*, July 26, 1877. The citizens of Boston were not without protection from dogs before the first official dog catcher was hired. An 1825 Boston city ordinance provided that dogs must be licensed and that the City Marshall could destroy a dog that had been declared a nuisance. *The Charter of the City Council of Boston and Ordinances Made and Established by the Mayor, Aldermen, and Common Council* (Boston, 1827), 108. And in later years the city had provisions for police officers to be assigned to kill unlicensed dogs in the summertime. *Ordinances and Rules and Orders of the City of Boston* (Boston, 1869), 152.

² Roswell McCrea, *The Humane Movement: A Descriptive Survey* (New York: Columbia University Press, 1910), 12; William Swallow, *Quality of Mercy: History of the Humane Movement in the United States* (Boston: Mary Mitchell Humane Fund, 1963), 16–17; Sydney Coleman, *Humane Society Leaders in America* (Albany, NY: American Humane Association, 1924), 89–97.

³ Bernard Unti, "The Quality of Mercy: Organized Animal Protection in the United States, 1866–1930" (PhD diss., American University, 2002), 196.

⁴ J. Fred Smithcors, *The American Veterinary Profession: Its Background and Development* (Ames: Iowa State University Press, 1963), 462; Philip Teigen, "Legislating Fear and the Public Health in Gilded Age Massachusetts" *Journal of the History of Medicine and Allied Sciences* 62, no. 2 (April 2007): 141, 144, doi:10.1093/jhmas/jrl016.

⁵ Teigen, "Legislating Fear," 166–167; Smithcors, *American Veterinary Profession*, 462.

⁶ "Capturing Canines," *Boston Daily Globe*, July 3, 1885; "Here in Boston," *Boston Post*, October 2, 1889; Al. Watts, *Al. Watts on Dogs; Their Habits, Characteristics, and Diseases* (Boston, 1876).

⁷ "Capturing Canines."

⁸ "Catching Characterless Canines," *Boston Daily Globe*, July 26, 1877.

⁹ Ibid.

¹⁰ "Capturing Canines."

¹¹ "Dog Hunts Begin Today," *Boston Daily Globe*, July 1, 1901.

¹² "The Dog Scoop" *Boston Post*, August 15, 1895.

¹³ Swallow, *Quality of Mercy*, 74–76; Coleman, *Humane Society Leaders*, 209; "Future of Cats," *Boston Sunday Post*, January 29, 1899; "Doomed Cats," *Boston Sunday Post*, March 12, 1899.

Association, and the ARL in turn inspired the formation of other animal rescue leagues.¹⁴ It was endorsed by George Angell.¹⁵ The founders of the ARL saw homeless cats in the city as suffering, and they encouraged people to bring their unwanted cats to the ARL rather than abandoning them.¹⁶

The ARL took in dogs, as well as cats, and it grew quickly. In its first year, it reportedly took in over 2,000 cats and several hundred dogs.¹⁷ In 1901, just two years after its founding, it took in 7,759 animals.¹⁸ The ARL sent out 1,500 circulars and posters to the beaches near Boston that year to remind people to take their unwanted cats to the ARL when they returned to the city.¹⁹ In 1906, the ARL's total intake was almost 19,000.²⁰ The number of cats taken in by the ARL in the 10 years from 1905 through 1914 was over 215,000, with 98% of them destroyed.²¹ Smith attributed the steady increase in the number of cats taken in to the increasing capacity of the ARL, not to an increase in the number of cats in the Boston area.²²

In 1908, the city of Boston appointed three ARL officials (including Smith's husband), as the city's dog catchers.²³ The city was motivated to make the change because the previous year the city dog catcher, who was a successor of Dr. Schenk, had been investigated for graft.²⁴ Existing law did not allow the ARL itself to enter into a contract with the city for dog control, so the city paid the three ARL officials a salary which they turned over to the ARL.²⁵ The ARL nevertheless lost \$1,000.00 per year on dog control because of the expense of doing the work humanely.²⁶

A controversy erupted in 1911 when the ARL was accused of selling dogs and cats for medical research.²⁷ Smith denied the allegation and said that all animals who were not reclaimed or placed as pets were killed with chloroform.²⁸ In 1922, when a city ordinance was proposed to allow medical schools to seize shelter animals, an ARL representative said that the organization never had and never would turn over an animal for experimentation.²⁹ The ARL is still in existence today and still takes in homeless animals, although Boston now has a municipal animal care and control department.

In the early 1900s, more and more cities followed the lead of Philadelphia, New York, and Boston and turned their dog pounds over to SPCAs and humane societies.³⁰ The issue of money was one that would continue to bedevil humane institutions that took over animal care and control duties for cities. Humane organizations were lucky if city contracts covered their expenses for animal control, much less the extra expenses it took to do animal care and control humanely.

¹⁴ Coleman, *Humane Society Leaders*, 208–209; William Shultz, *The Humane Movement in the United States, 1910–1922* (New York: Columbia University Press, 1924), 65.

¹⁵ "Future of Cats."

¹⁶ *Ibid.*

¹⁷ Helen Winslow, *Concerning Cats: My Own and Some Others* (Boston: Lothrop, Lee & Shepherd, 1900), 199–200.

¹⁸ "Cared for 7759 Animals," *Boston Daily Globe*, February 5, 1902.

¹⁹ *Ibid.*

²⁰ "More Funds Needed by Animal Rescue League," *Boston Post*, February 19, 1907.

²¹ Edward Forbush, *The Domestic Cat—Bird Killer, Mouser and Destroyer of Wildlife—Means of Utilizing and Controlling It* (Boston: Wright & Potter, 1916), 20.

²² *Ibid.*, 20–21.

²³ Swallow, *Quality of Mercy*, 76; "3 Official Dog Catchers," *Boston Post*, June 24, 1908.

²⁴ "3 Official Dog Catchers"; "Dead Dogs Next: Finance Commission Will Turn Light on City Killer's Bills," *Boston Post*, October 29, 1907.

²⁵ "Declares Animal Rescue Officials Mulcted City," *Boston Post*, May 24, 1910.

²⁶ *Ibid.*

²⁷ "Deny Sale of Animals," *Boston Post*, February 26, 1911.

²⁸ *Ibid.*

²⁹ "Animals Not for Doctors," *Boston Post*, November 15, 1922.

³⁰ Stephen Zawistowski, *Companion Animals in Society* (Clifton Park, NY: Thomson Delmar Learning, 2008), 75.

Because the Massachusetts SPCA was not responsible for animal control in the late 1800s and early 1900s, George Angell was able to concentrate on humane education, an issue he felt was very important. Efforts to teach children an ethic of kindness to animals predated the Civil War.³¹ The theory of early humane educators was that if children were taught kindness to animals, they would apply those lessons in all of their dealings with humans and animals.³² In those days, advocates had great hopes that humane education would wipe out cruelty and help perfect humankind.³³

The post-Civil War humane movement directed humane education at both adults and children. Lectures on issues of the day were a popular activity at the time and preventing animal cruelty was a frequent topic.³⁴ Humane education for adults included material targeted at working men who used animals, particularly horses, in their daily labors. Pamphlets and cards with simple rules were distributed. “Sponge horses under collar and saddle,” and “[s]table foreman should be good tempered and not a drinking man” were examples.³⁵ The Illinois Humane Society went further and offered a series of classes for men who worked with horses.³⁶ These popular classes were given in the evening and covered topics such as the economic cost of overloading horses, how to prevent harness sores, and the scope of the anti-cruelty laws.

In 1882, Angell and Thomas Timmins, a unitarian minister from England, founded an international humane organization for children called Bands of Mercy.³⁷ A practical aspect of the Bands of Mercy program was to give children guidelines for humane treatment of animals. The “suggestions” for one Band of Mercy in England were aimed at boys and directed them not to take eggs from bird nests (or, if they must take eggs, to leave one or two), not to chase butterflies, to take regular care of pets, to feed wild birds in the wintertime, and to speak kindly rather than roughly in correcting boys who committed acts of cruelty.³⁸ In 1889, Angell founded the American Humane Education Society (AHES), which became an organization with international reach.³⁹



Figure 14:
Band of Mercy formed by the Women’s Branch SPCA in Philadelphia. Photo from the collection of Women’s Animal Center, America’s First Animal Shelter – formerly known as Women’s Humane Society for the Prevention of Cruelty to Animals.

³¹ Janet Davis, *The Gospel of Kindness: Animal Welfare and the Making of Modern America* (New York: Oxford University Press, 2016), 33–37.

³² Katherine Grier, *Pets in America: A History* (Chapel Hill: University of North Carolina Press, 2006), 142–146.

³³ See, e.g., Lydia Maria Child, writing of the dog roundup in New York City in 1841, who asked whether “such brutal scenes do not prepare the minds of the young to take part in bloody riots and revolutions.” Lydia Maria Child, *Letters from New-York: A Portrait of New York on the Cusp of its Transformation into a Modern City*, ed. Bruce Mills (Athens, GA: University of Georgia Press, 1998), 15. Angell believed that humane education could help integrate disadvantaged children into society and prevent socialist revolution.

Davis, *Gospel of Kindness*, 77–80; Bernard Unti and Bill DeRosa, “Humane Education Past, Present, and Future,” in *The State of the Animals II: 2003*, ed. Deborah Salem and Andrew Rowan (Washington, DC: Humane Society Press, 2003), 28.

³⁴ McCrea, *Humane Movement*, 90, 106.

³⁵ *Ibid.*, 101.

³⁶ *Ibid.*, 102–105.

³⁷ Davis, *Gospel of Kindness*, 48, 63; McCrea, *Humane Movement*, 94–98.

³⁸ McCrea, *Humane Movement*, 96–97.

³⁹ Swallow, *Quality of Mercy*, 62–64; Shultz, *Humane Movement in the United States*, 121–123.

In addition to the organizational approach to promoting kindness, Angell invested heavily in an effort to create empathy for animals in children by using stories. The basis for this approach was the idea that if children could identify with animals and imagine themselves in the place of an animal, they would naturally want to treat animals kindly.⁴⁰ Today we have some expert evidence for the proposition that stories are a good way to shape children's moral education.⁴¹

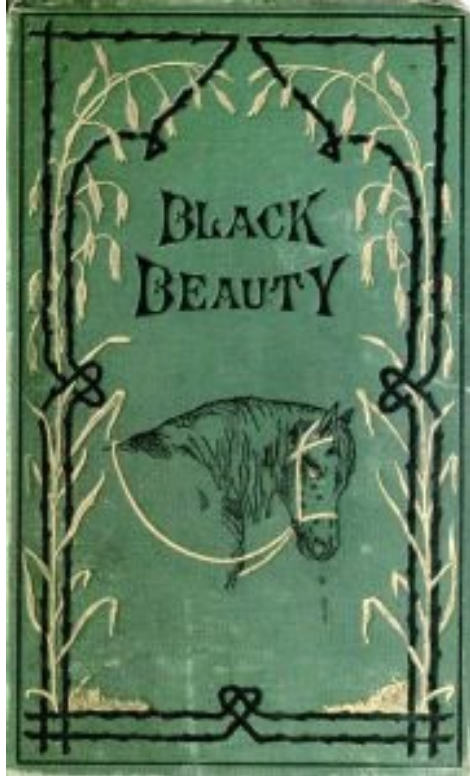

Figure 15:
Cover of *Black Beauty*, by Anna Sewell, published in 1877.
Public domain.

Angell promoted a genre of children's fiction called the "animal autobiography" that was popular in the 1800s in England.⁴² In these tales, an animal tells its life story in the first person as though it were writing the story itself. The stories are realistic except for the device that the animal is speaking in its own voice. The animal autobiography was part of a larger genre of 19th century British children's fiction that featured talking animals. The hope for the genre was that it would instill morality and compassion for animals in children while amusing and engaging them at the same time.⁴³

Possibly the most effective, and certainly the most popular, of the animal autobiographies was the novel *Black Beauty*, by Anna Sewell, published in England in 1877.⁴⁴ Angell published the first edition of *Black Beauty* in the United States in 1890 and distributed two million free copies.⁴⁵ *Black Beauty* is generally considered to be a children's book, but Sewell did not direct it specifically at children.⁴⁶ In fact, the book works on several levels, from a guide to proper treatment of horses to questioning the nature of the human-animal relationship to a metaphor for slavery in the 19th century.⁴⁷ The novel even reflects the class structure of the times. Early in the narrative, Black Beauty's mother takes him aside and tells him that he

must behave better than the cart-horse foals he plays with because he is of better breeding.⁴⁸ Angell, who was concerned about the broad effect of animal cruelty on society, was aware of the potential of the novel to reach both adults and children.⁴⁹ He did not limit the distribution of the book to children, and gave copies of it to drivers of horse-drawn vehicles.⁵⁰

⁴⁰ Grier, *Pets in America*, 175.

⁴¹ Marion Copeland and Heidi O'Brien, "Toward Biophilia: The Role of Children's Literature in the Development of Empathy and Compassion," in *State of the Animals II*, 51–52. Some studies of animal activism have indicated that developing a sense of empathy for animals may be a factor in an individual's choice to become an animal activist. Bernard Unti and Andrew Rowan, "A Social History of Postwar Animal Protection," in *The State of the Animals: 2001*, ed. Deborah Salem and Andrew Rowan (Washington, DC: Humane Society Press, 2001), 27.

⁴² Tess Cosslett, *Talking Animals in British Children's Fiction, 1786–1914* (Aldershot, UK: Ashgate Publishing, 2006), 63.

⁴³ *Ibid.*, 39.

⁴⁴ Anna Sewell, *Black Beauty: His Grooms and Companions* (London, 1877).

⁴⁵ *Animals, People, and the MSPCA: 125 Years of Progress* (Burlington, VT: Massachusetts Society for the Prevention of Cruelty to Animals, 1993), 3. Over 50 million copies of *Black Beauty* have been distributed, and it is one of the most popular of all books.

⁴⁶ Copeland and O'Brien, "Toward Biophilia," 56; Cosslett, *Talking Animals*, 74–75.

⁴⁷ Cosslett, *Talking Animals*, 75–81, 89; Davis, *Gospel of Kindness*, 42.

⁴⁸ Cosslett, *Talking Animals*, 84.

⁴⁹ Copeland and O'Brien, "Toward Biophilia," 55.

⁵⁰ Cosslett, *Talking Animals*, 74.

Black Beauty is written in the first-person voice of its narrator, the eponymous horse. It uses several devices to negate the narrative distance between its human readers and its putative animal author.⁵¹ The prose style is simple and, for the most part, unsentimental. As one reads the book, it comes to seem natural that *Black Beauty* is able to converse with other horses and communicate his memoirs to the reader, and the “autobiographical” device quickly fades into the background. The novel is effective at getting readers to imagine themselves in an animal’s head, thinking and feeling as an animal would.

Sewell made her points organically in the course of the narrative rather than presenting them overtly as a plea for kindness. Those points included the fact that there are both cruel people and humane people in the world and an animal cannot choose which type of owner it has. *Black Beauty* talks matter-of-factly about his reactions to the various types of tack and harnesses that were used at the time, including the bearing rein, which was used to hold carriage horses’ heads up in an unnatural position. *Black Beauty* was a factor in the abolition of the bearing rein in England.⁵² The novel also inspired Ann Lindo to found the Home of Rest for Horses in England in 1886, where horses who were temporarily unfit for work could be rehabilitated and returned to their jobs.⁵³

People who criticize Sewell for anthropomorphizing a horse may be missing the point. No one other than a young child would take the device of a horse writing a book literally. The point of the first-person device is to underline that on the level of feeling, animals are similar to people. Animals can feel emotions, have bad temperaments or good, and be influenced by their upbringing. On that level it does not matter that horses cannot write or talk.

The same theme of an animal speaking in the first person about its life was used in a book by Margaret Marshall Saunders about a dog called *Beautiful Joe*, published in 1894 by AHES.⁵⁴ This book used the dog’s narrative to call attention to various types of physical abuse that dogs experience, such as tail docking and ear trimming. We don’t know whether *Black Beauty*, *Beautiful Joe*, and other such books inspired long-lasting empathy for animals in the children (and adults) who read them, but the approach seems logical and it is easy to understand the appeal it had to early humane educators. Whether we equate “sentiment” with “sentimental” or not, it seems almost axiomatic that childhood feelings can help shape adult beliefs and actions.

Some educators viewed humane education as important primarily or entirely because of its salutary effect on people, rather than any benefit to the animals. A 1906 set of humane-education principles for schools in a California city stated, for example: “The temporary desires and pleasures of the inferior animals are to be taken into consideration, rather in view of the effect of their recognition upon human character, than from the standpoint of the positive rights of the animals themselves.” According to these instructions, sympathy for animals should not be “spasmodic [or] overwrought” but instead should be guided “along proper lines” of preserving economic value, helping society, and improving character.⁵⁵

A recurring theme of humane education was that a pet owner had a duty to kill a no-longer-wanted pet, rather than abandon it outdoors.⁵⁶ John Lawrence, an Englishman, put the case for this view strongly in a 1796 book, arguing that if a person no longer wanted a dog or cat, they should kill it rather than abandon

⁵¹ Ibid., 69–70.

⁵² Ibid., 74.

⁵³ “The Home of Rest for Horses,” *The Horse Trust*, accessed April 7, 2017, <http://www.horsetrust.org.uk/history/yesterday/home-of-rest-for-horses-1886>.

⁵⁴ Marshall Saunders, *Beautiful Joe: An Autobiography* (Philadelphia, 1896); Davis, *Gospel of Kindness*, 65.

⁵⁵ McCrea, *Humane Movement*, 91–93.

⁵⁶ Grier, *Pets in America*, 104–105.

it. He asked: “Who do [the owners] expect will entertain a poor forlorn stranger” whom they themselves “would drive back . . . from their own door?”⁵⁷ He describes the state of mind of a pet “exiled” from its comfortable home and “exposed to all the horrors of famine, wet and cold, and to the constant apprehension of insult and torture, pining for the loss of its happy home.” Harriet Beecher Stowe, in an 1896 book for children, praised a young girl who drowned a homeless kitten after taking it from some boys who were tormenting it.⁵⁸

Today, some people believe that the humane-education movement of the late 1800s and early 1900s had only marginal impact. It is worth noting, though, that by the 1920s gratuitous cruelty toward animals was no longer accepted by society. One observer of the early humane movement, writing in 1910, stated that “conditions have undergone marked change since the earlier days of anti-cruelty work” and the “grosser forms of cruelty are now exceptional.”⁵⁹ This change in the attitude of the general public probably had many causes, including the fact that by 1920 humane organizations had succeeded in criminalizing gratuitous cruelty to animals,⁶⁰ but it seems reasonable to think that early humane education also had an influence.

The humane movement of which humane education was a part made great strides in the period from 1866 to the early 1900s, but the momentum of the movement stalled by 1920.⁶¹ Various reasons have been proposed to explain this phenomenon, including the passing of the charismatic leaders who started the movement, the replacement of the horse by the car, the relocation of livestock out of the city and out of sight, disruptions caused by World War I, and changing alignments within the movement.⁶² One of the main reasons for the stalling of the humane movement though, was that by 1920 many humane organizations had become deeply involved in the overwhelming day-to-day task of caring for homeless dogs and cats. The public-private partnerships in animal sheltering that had become common by 1920 would continue throughout the 20th century, and would significantly affect both sheltering and the humane movement.

⁵⁷ John Lawrence, *A Philosophical and Practical Treatise on Horses, and on the Moral Duties of Man Towards the Brute Creation* (London, 1796), 160.

⁵⁸ Harriet Beecher Stowe, “Aunt Esther’s Rules,” in *Stories and Sketches for the Young* (1855; repr., Boston: Houghton Mifflin, 1896), 111–112.

⁵⁹ McCrea, *Humane Movement*, 59.

⁶⁰ Emily Leavitt and Diane Halverson, “The Evolution of Anti-Cruelty Laws in the United States,” chap. 1 in *Animals and Their Legal Rights: A Survey of American Laws from 1641 to 1990*, 4th ed. (Washington, DC: Animal Welfare Institute, 1990), 4.

⁶¹ Unti and Rowan, “A Social History of Postwar Animal Protection,” 21.

⁶² Davis, *Gospel of Kindness*, 215–216; Charles Niven, *History of the Humane Movement* (London: Johnson Publications, 1967), 109–111; Lawrence Finsen and Susan Finsen, *The Animal Rights Movement in America: From Compassion to Respect* (New York: Twayne Publishers, 1994); 50–51; Unti, “Quality of Mercy,” 676–682; Unti and Rowan, “A Social History of Postwar Animal Protection,” 21; Shultz, *Humane Movement in the United States*, 57–58.

Part II: The Traditional Animal Shelter

Chapter 5: Shelter Operations in the 20th Century

As cities grew in the 1900s, so did the number of animal shelters. The distinction that had developed in the late 1800s between public and private shelters continued in the 20th century. “Public” shelters, often called “municipal” shelters, were operated by the city or county government and had the duty to do animal control and take in strays. Many public shelters also accepted “owner surrenders” from people who either no longer wanted their pets or could no longer care for them. “Private” shelters, run by individuals or non-profit organizations, did not have any legal duty to do animal control or take in strays or owner surrenders, unless they created such a duty for themselves by contract with a city or county.

Animal control was a routine function of local government in the 20th century, but jurisdictions varied widely in how they carried it out.¹ There were several reasons for the variations. One was the degree of involvement of the private sector. Involvement of the private sector ran the gamut from volunteers who did menial tasks at the municipal shelter to full management of the municipal shelter granted by contract to a humane organization, including delegation of the police powers necessary to do animal control. A common arrangement was a public-private partnership where the city or county did animal control and a private humane organization assumed part or all of the burden of animal care and disposition.

State laws and local ordinances could create differences in public shelter operations from one jurisdiction to the next.² Holding periods for stray animals and policies for feral cats are examples of animal issues that were often addressed in laws and ordinances.

The level of funding for shelters varied widely from place to place. A study in the state of New York in the early 1970s found everything from “small, inadequately financed shelters with little community acceptance” to “large, professionally staffed and community supported operations.”³ Four counties in the state had no shelters at all, including one with a population of over 100,000 people.⁴ The problem of funding variations has persisted. A study published in 2008 showed that per capita spending on animal control in a sample of 10 jurisdictions nationwide ranged from a low of \$2.11 per person in New York City to a high of \$14.12 in San Francisco.⁵ And even today there are counties with no formal animal control services.⁶

Private shelters that have no contractual relationship with a government and no duty to take in owner surrenders or strays can, if they wish, avoid killing adoptable animals simply by limiting their intake to the number of animals they can care for. Shelters that rejected the killing of adoptable animals have existed in the United States since the late 1800s, but such shelters were rare until the 1970s.⁷ For most of the 20th century, most private humane organizations that operated shelters treated their intake much as public

¹ Stephen Zawistowski, *Companion Animals in Society* (Clifton Park, NY: Thomson Delmar Learning, 2008), 76.

² Stephen Aronson, *Animal Control Management: A New Look at a Public Responsibility* (West Lafayette, IN: Purdue University Press, 2010), 247–284. Ohio, for example, has a county-based system of dog wardens. Ohio County Dog Wardens Association, Internet Archive, <https://web.archive.org/web/20161111122031/http://ocdwa.com/about.html>.

³ Argus Archives, *Unwanted Pets and the Animal Shelter: The Pet Population Problem in New York State*, Report Series # 4 (n.p.: Argus Archives, 1973), 2.

⁴ *Ibid.*, 31.

⁵ Zawistowski, *Companion Animals in Society*, 77, table 4–1. New York City may be something of a special case because its housing stock is less conducive to pet-keeping. Therefore its per capita spending may not be readily comparable to the average jurisdiction.

⁶ For example, 30 counties in Georgia reported in a 2015 survey that animal control services were not available in their county. “Animal Control Services Provided Within Jurisdiction: Method of Service Provision Reported by Counties,” Georgia Department of Community Affairs, accessed April 8, 2017, <https://www.dca.ga.gov/development/research/programs/documents/2016AnimalControl.pdf>.

⁷ See chapter 12.

shelters did, by killing most of them. Taking in homeless animals was seen as a moral duty to prevent suffering, and it was a point of pride for many private shelters to never turn away a homeless animal.

The mix of public and private involvement in animal care and control may have hindered the development of standard models of operation, but the involvement of the private sector greatly increased available resources. Private humane organizations were not always happy about the burden they carried, because the time and money they spent on caring for homeless pets meant that they had fewer resources for other core missions, such as lobbying for humane treatment of livestock and research animals.

At a conference in 1974, the president of the Humane Society of the United States (HSUS), John Hoyt, spoke of the long history of humane organizations having to step in and do animal control and sheltering, spending their own funds because no one else would do it.⁸ Barbara Cassidy of HSUS argued at a 1987 conference that municipalities should pay the full cost of animal control and sheltering so that humane societies could work on things like humane education and preventing cruelty.⁹ John Kullberg, president of the ASPCA, stated at the 1987 conference that the ASPCA was subsidizing New York City for over \$1.5 million yearly in operating costs.¹⁰ Kullberg contrasted the ASPCA's situation with that of the city-run shelters in Chicago and the city of Los Angeles, where the local governments funded the shelters more generously.¹¹

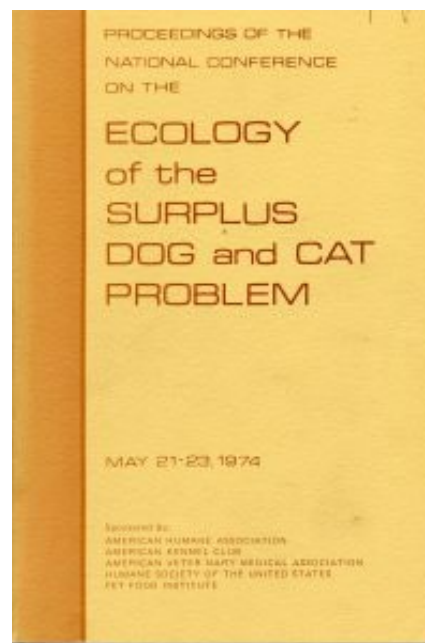

Figure 16:
Cover of the proceedings of the 1974 national conference on sheltering issues. From author's collection.

Shelters that had adequate funding, whether they were large private organizations or the occasional well-funded municipal system,¹² became the leading institutions in animal sheltering in the 1900s. These elite shelter systems had the resources to offer training to staff, hire talented directors, and send their directors to national conferences.¹³ Their directors were the voice of the traditional shelter establishment and they were influential in determining shelter standards of the day. These organizations represented only a small percentage of shelters though, and there was a substantial resources gap between them and the great mass of cash-starved municipal shelters.¹⁴

Municipal animal shelters were frequently a low priority for cities and counties.¹⁵ Both government run animal shelters and private organizations that ran public shelters under contract often operated with little

⁸ John Hoyt, "A Case for Spay/Neuter Clinics," in *Proceedings of the National Conference on the Ecology of the Surplus Dog and Cat Problem*, May 21–23, 1974 (Denver: American Humane Association, 1974), 61–62.

⁹ Barbara Cassidy, "Who is Responsible for Pet Over Population?," in *Overpopulation of Cats and Dogs: Causes, Effects, and Prevention*, ed. Marjorie Anchel (New York: Fordham University Press, 1990), 50, 52.

¹⁰ John Kullberg, "Responsibilities of Shelters," panel discussion in *Overpopulation of Cats and Dog*, 116.

¹¹ *Ibid.*, 116–117.

¹² Gretchen Wyler, "Animal Control: How is it Best Handled?," in *Overpopulation of Cats and Dogs*, 27–32.

¹³ Elisabeth Clancy and Andrew Rowan, "Companion Animal Demographics in the United States: A Historical Perspective," in *The State of the Animals II: 2003*, ed. Deborah Salem and Andrew Rowan (Washington, DC: Humane Society Press, 2003), 23.

¹⁴ Bernard Unti, *Protecting All Animals: A Fifty-Year History of the Humane Society of the United States* (Washington, DC: Humane Society Press, 2004), 85.

¹⁵ Mel Morse, "Common Goals of Animal Control and the Community," in *Proceedings of the National Conference on Dog and Cat Control, February 3–5, 1976* (Denver: American Humane Association, 1976), 153; Stephen Zawistowski et al., "Population Dynamics, Overpopulation, and the Welfare of Companion Animals: New Insights on Old and New Data," *Journal of Applied Animal Welfare Science* 1, no. 3 (1998): 195, doi:10.1207/s15327604jaws0103_1.

oversight or regulation.¹⁶ As one commentator wrote about the early 1970s, it was “difficult to convey” to beginners in animal welfare work how “isolated and lacking in resources shelter work could be.”¹⁷ The authors of a 1973 survey reported that workers in shelters in New York were “so busy coping with everyday problems that they had little time for anything else.”¹⁸ Municipal animal sheltering was so neglected in many communities that even basic things like ordinances, procedures, and training received little or no attention.¹⁹

In the early 1970s, in Otsego County, Michigan, the sheriff held impounded animals in an unheated concrete block cell and killed them by gunshot.²⁰ Animal control officers in the Corvallis, Oregon, area in the 1970s sometimes shot dogs that were chasing livestock.²¹ The rural “shelter” that served Kane County and the town of Kanab in Utah in the early 1980s was a tin roofed shed in an open field in the desert, where a veterinarian came once a week to kill the occupants.²²



Figure 17:
Corridor runs for dogs are often divided into two parts, inside and outside, connected by a small door. Photograph by Andreas Bohnenstengel, licensed under CC BY SA-3.0 DE.

Gretchen Wyler,²³ an actor who became an animal welfare activist, was motivated to get involved in humane work after visiting a dismal local shelter in Warwick, New York, in 1966.²⁴ She described it as a “very medieval dungeon where the rats were killing the puppies.” The location was “in the village dump amidst burning garbage.” Every week a truck came “and took the animals off for research.” Wyler led a movement to reform the shelter, and in October 1968 it was relocated to a new facility, which Wyler oversaw for the next 10 years.²⁵

The period from the mid-1800s to the late 1900s saw two generations of animal shelter buildings. The first generation housed animals in large, open “gang pens.” This type of building, which was common from before the Civil War until after World War II,²⁶ was primarily for housing dogs. The dogs were typically kept for only a short holding period during which owners could reclaim them. If the hold period was 48 hours, for example, all the dogs brought in on Monday were put in one pen and held there through Wednesday, when the unclaimed dogs in that pen were killed. Another pen held dogs

¹⁶ Jacqueline Vaughn, “The Shelter Charade: The Dilemmas of Urban Animal Control,” *State & Local Government Review* 10, no. 3 (September 1978): 90.

¹⁷ M. Carrie Allan, “A Good Man in a Hard Job,” *Animal Sheltering Magazine*, September/October 2014, 28.

¹⁸ Argus Archives, *Unwanted Pets and the Animal Shelter*, 32. The overwhelming magnitude of shelter intake and the resultant lack of time to even think about solutions is a consistent theme in interviews with people who were shelter directors and employees in the 1970s and 1980s. Douglas Fakkema, who was a shelter director in Oregon and California in the 1970s and 1980s, spoke of having 100 animals a day on average come into the Eugene, Oregon, shelter in the early 1970s. Douglas Fakkema, interviews by author, May 4, 2015 and May 14, 2015.

¹⁹ Unti, *Protecting All Animals*, 90–94.

²⁰ Melissa Fitzgerald, “Case Study: Michigan’s 1st No Kill Community” (presentation, Michigan Pet Fund Alliance, 2012).

²¹ Douglas Fakkema, interviews.

²² Francis Battista, interview by author, September 22, 2014.

²³ In December 1971, Wyler became the first female ASPCA board member in the history of the organization. Marion Lane and Stephen Zawistowski, *Heritage of Care: The American Society for the Prevention of Cruelty to Animals* (Westport, CT: Praeger, 2008), 39; Wyler, “Animal Control,” 26.

²⁴ *Ibid.*, 26; “Gretchen Wyler: A Lifetime of ‘Stage Lefts’ and ‘Animal Rights,’” *Gretchen Wyler*, accessed April 8, 2017, <http://www.gretchenwyler.com/bio.html>.

²⁵ Zawistowski, *Companion Animals in Society*, 78, 90.

²⁶ Zawistowski, *Companion Animals in Society*, 78, 90.

impounded on Tuesday, who were held through Thursday, and so forth. The gang pen system allowed for efficient identification of dogs whose time was up.

The second generation of municipal shelters, which became standard in the latter half of the 20th century, featured low cost, functional buildings designed for processing large numbers of animals. They were often located as close to a landfill as possible to make it convenient to dispose of the bodies of animals killed by the shelter. These shelters frequently had loading docks in the back where trucks could be filled with dead animals for transport to the landfill.

One of the features of the second generation of shelters was individual runs for dogs instead of gang pens. This was called “corridor housing” because it typically consisted of long corridors with runs opening off of one or both sides. Having one dog in each run helped control disease and made cleaning easier but it resulted in boredom and isolation for the dogs, who could not interact normally with their neighbors. Although corridor housing was generally designed for one dog per run, shelters sometimes put multiple dogs together in a run when they ran short of space.

The transition from the first generation to the second generation of shelter buildings was a gradual process, but by the 1970s, gang pens were becoming uncommon. In Denver, the city animal control shelter transitioned from gang pens in the 1970s.²⁷ In Yolo County, California, a second-generation shelter that replaced the gang pens was built in 1971.²⁸ In the original Yolo County pound, which was built in 1936, the gang pens held from 18 to 25 dogs each. The corridor-style runs in the new shelter held one to three dogs each.

A state-of-the-art second-generation facility in the 1970s had two sections in each dog run, so that a dog could be shut in one part of the run while the other was cleaned.²⁹ An underfinanced city pound, however, might have only one section in each run. Shelter workers would either have to hose down the runs with the dogs in them, which was abusive, or take out and secure dogs for each run each time they cleaned.

Disease prevention was a challenge in municipal shelters. Animal control officers were often responsible for picking up both live and dead animals, and in many cases their vehicles did not have adequate means to separate them. This meant that live animals were sometimes exposed to pathogens from animals who had just died from disease.³⁰ Live and dead animals were unloaded together at the shelter, and people who then redeemed their lost pet might take home diseases with the pet.³¹ The prevalence of diseases among shelter animals sometimes caused veterinarians to advise people against adopting an animal from a shelter.³²

Animals who made it into the shelter without catching a disease in transport were not safe, because many shelters had no facilities for isolation of sick animals. Many of the second-generation shelters were built of materials that harbored bacteria and viruses, and the buildings frequently had poor air circulation. Animals who got sick were killed to keep them from spreading disease. Even when animals had illnesses that were

²⁷ Robert Rohde, interview by author, March 26, 2014.

²⁸ “Yolo’s New Dog Pound Rates Highly,” *Daily Democrat*, February 9, 1972.

²⁹ Edwin Sayres, interview by author, August 3, 2014.

³⁰ Morse, “Common Goals,” 155–156.

³¹ *Ibid.* 156.

³² *Ibid.*

easily treated, the cost of treatment could be a prohibitive factor.³³ Sterilizing a shelter building following a major disease outbreak often meant killing all the animals, including the healthy ones.

It was a tradition going back to the 1800s for public shelters to try to make it easy for owners to surrender unwanted pets. “Drop boxes”—cages or pens where animals could be dropped off when the shelter was closed, were common.³⁴ Drop boxes ranged from simply a few cages set outside the shelter at night to quite elaborate indoor-outdoor holding pens with climate control and safeguards for the animals. In recent decades, drop boxes have become a point of controversy.³⁵ Their proponents believe that allowing people to drop off an animal at any time, anonymously, prevents animal abandonment. Opponents believe that drop boxes facilitate retaliatory pet theft, are dangerous for animals when unsupervised, and encourage people to think of giving up pets as a casual decision.³⁶

A common rationale cited for shelter killing in the 1900s was lack of time or space to continue to care for an animal. A 1998 survey of 186 shelters in the United States found that on average, shelters had capacity for an animal to remain only 9.5 days.³⁷ Shelters are typically required to hold unidentified impounds for a certain amount of time mandated by state or local law, and that can lead to shelter crowding. One way many shelters dealt with crowding was to kill owner surrendered animals on intake, since hold periods generally did not apply to owner surrenders.

The widespread policy of accepting any animal that came to the door added to the “time or space” problem because it made planning for workload difficult. Animal control raids also contributed to the issue of unpredictable workload. Animal control officers sometimes had to confiscate substantial numbers of animals, as when puppy mills were closed for cruelty or when hoarding or dog fighting cases were discovered.³⁸ Ownership of confiscated animals might be contested, sometimes leading to drawn-out court proceedings during which the shelter had to house the animals. Animals from such situations were often in poor condition and required expensive care.

A somewhat predictable influx of animals happened each year in “kitten season,” the spring and early summer period when both feral and tame cats have litters. For most of the 1900s, there was also an onslaught of litters of puppies in spring and early summer. Kittens and puppies too young for immediate adoption were another group of animals often routinely killed on intake.³⁹

Because most shelters adopted out only a small percentage of their animals in the 1900s, there was a tendency to make only young, healthy, attractive, friendly animals available for adoption.⁴⁰ Relatively few shelter animals are considered unadoptable today, generally 10% or less, but a much higher percentage were classified as unadoptable in the 1900s. As late as 1998, a large survey found that shelters on average

³³ Arnold Arluke, “Managing Emotions in an Animal Shelter,” chap. 8 in *Animals and Human Society: Changing Perspectives*, ed. Aubrey Manning and James Serpell (1994; repr., New York: Routledge, 2011), 149–150.

³⁴ Katherine McGowan, “Night-Drop Kennels for Animals: The Good, the Bad, and the Ugly,” *Animal Sheltering*, March–April 2007, 38.

³⁵ *Ibid.*, 35–38.

³⁶ The Association of Shelter Veterinarians recommends against the use of unattended drop boxes. Sandra Newbury, et al., *Guidelines for Standards of Care in Animal Shelters* (Apex, NC: Association of Shelter Veterinarians, 2010), 11, accessed March 18, 2018, <http://www.sheltervet.org/assets/docs/shelter-standards-oct2011-wforward.pdf>.

³⁷ John Wenstrup and Alexis Dowidchuk, “Pet Overpopulation: Data and Measurement Issues in Shelters,” *Journal of Applied Animal Welfare Science* 2, no. 4, (1999): 309, doi:10.1207/s15327604jaws0204_5.

³⁸ Kullberg, “Responsibilities of Shelters,” 101.

³⁹ Brenda Fowler, “Like Cats and Dogs,” *Chicago Reporter*, March 2003; Richard Avanzino, interview by author, March 3, 2015.

⁴⁰ *1999 Adoption Forum* (Englewood, CO: American Humane Association, 1999), 2.

classified 39% of their intake as unadoptable.⁴¹ Behavior was the most common reason, applying to 40% of unadoptable dogs and 41% of unadoptable cats.⁴²

In the 1950s, many shelters began to use restrictive adoption criteria to screen potential adopters.⁴³ One shelter in 1953, for example, had a policy that barred a family from adopting if the adults worked and no one would be home with the animal.⁴⁴ A pet could not be adopted as a gift at that shelter, and a cat could not be adopted to someone who wanted it for controlling rodents. Puppies and kittens could not be placed in homes with small children. The use of adoption interviews and questionnaires became common in the 1970s.⁴⁵ Restrictive adoption policies and practices remained common throughout the rest of the 20th century.⁴⁶

Shelters took widely varying approaches to impoundment of cats. Many jurisdictions did not impound cats at all. Public shelters that did take in cats frequently restricted their intake to “over the counter,” meaning that local residents were allowed to surrender owned cats or drop off cats they had trapped, but animal control officers would not routinely trap cats in the field.⁴⁷ In the Los Angeles city shelter system in fiscal year 1969 to 1970, animal control officers caught 9,765 dogs, but only 270 cats.⁴⁸ And less than half as many cats as dogs were picked up by request. The only intake category where cats exceeded dogs in Los Angeles that year was animals brought to the shelter by the public.

Some shelters loaned traps to people to catch “nuisance” cats.⁴⁹ When a trap was returned to the shelter with a cat inside, the cat was often killed either on intake or after expiration of a holding period. The Yolo County, California, shelter accepted cats brought in by residents in the early 1970s, but did not keep statistics on how many they handled or their outcomes.⁵⁰ In shelters where cats were impounded, they were often housed in cages where they could hear dogs barking and see dogs being moved around.⁵¹

The treatment of cats as an afterthought was partly due to the historical emphasis on dog control that arose from fear of rabies and the nuisances caused by dogs. Those concerns led to widespread licensing requirements for dogs in the 1800s, and the revenue from licensing was traditionally used to offset the costs of animal control.⁵² Cats were (and still are) very commonly considered to be free roaming, and therefore not requiring licensure.⁵³ Animal control management thus had a motive to focus on revenue-producing dogs rather than cats.

⁴¹ Wenstrup and Dowidchuk, “Pet Overpopulation,” 308, table 4.

⁴² *Ibid.*, 309, table 5.

⁴³ *1999 Adoption Forum*, 1–2.

⁴⁴ *Ibid.*

⁴⁵ *Ibid.*, 2.

⁴⁶ *Ibid.*

⁴⁷ An example was Baltimore, where animal control officers as late as the 1970s did not routinely pick up stray cats. Alan Beck, *The Ecology of Stray Dogs: A Study of Free-Ranging Urban Animals* (1973; repr., West Lafayette, IN: Purdue University Press/NotaBell Books, 2002), 44.

⁴⁸ MVP Special Report, “Short Fuse on the Pet Population Bomb,” *Modern Veterinary Practice* 52, no. 3 (March 1971).

⁴⁹ The San Francisco SPCA loaned traps to people before Richard Avanzino stopped the practice shortly after he became president of the SPCA in 1976. Avanzino, interview.

⁵⁰ “Yolo’s New Dog Pound Rates Highly.”

⁵¹ Sayres, interview.

⁵² William Hooper, “Municipal Animal Control Ordinances,” in *Proceedings of the National Conference on Dog and Cat Control*, 111.

⁵³ Martha Armstrong, Susan Tomasello, and Christyna Hunter, “From Pets to Companion Animals,” in *The State of the Animals: 2001*, ed. Deborah Salem and Andrew Rowan (Washington, DC: Humane Society Press, 2001), 81.

The hold periods of a few days that most states or localities set to allow owners to reclaim their stray pets did not work well for cats. In the 1970s, some ordinances provided for only a 48-hour hold period before an animal found at large could be killed, and did not require that the shelter notify owners of pets with identification.⁵⁴ More commonly, ordinances required that owners of animals with identification were to be notified, and unidentified animals were to be held for three to five days, unless they were sick or injured, in which case they could be killed immediately.⁵⁵ Those time limits were set up with dog owners in mind, because people notice quickly when their dog has disappeared. People expect cats to roam, and it might take the owner of a missing cat two or three weeks to decide to visit the shelter. By that time, the shelter would have killed the cat or, if the cat was very lucky, adopted it out to a new home.

Return-to-owner rates for cats hovered around the 2% to 3% level in the 1990s, compared to about 15% for dogs.⁵⁶ The difference in reclaim rates was one reason that cats were considerably more likely than dogs to be killed in a shelter. A large national survey of shelters in the mid-1990s found that 71% of impounded cats were killed versus 56% of impounded dogs.⁵⁷ A 1998 shelter survey found a kill rate of 65% for cats and 52% for dogs.⁵⁸ (These surveys may have understated the typical kill rate because many shelters declined to participate and it could have been the better-functioning shelters that responded.)

Reuniting lost pets with their owners, whether the pets were cats or dogs, was not a priority in many shelters. Gretchen Wyler described in 1987 how in shelters she visited the return-to-owner system was often “a bulletin board filled with yellow papers that have been stuck up there for years, that no one even looks at.”⁵⁹ In large metropolitan areas with several shelters, it could be very daunting for an owner to look for a lost animal. Before the internet era, and sometimes even afterward, people had to visit each shelter in their area in person. The restricted hours of operation typical of municipal shelters made it difficult for working people to visit them to look for a lost pet.

Animal sheltering is a labor-intensive endeavor, and services such as lost-and-found and adoption suffered when there were not enough employees. Employees were needed for necessities such as cleaning kennels, answering animal control calls, and accepting owner surrenders. Helping people decide on an animal to



Figure 18:
This type of arrangement for cat cages is typical in many shelters.
Photograph by Ciell, licensed under CC BY-SA 3.0

⁵⁴ Hooper, “Municipal Animal Control Ordinances,” 113.

⁵⁵ Ibid.

⁵⁶ “The Shelter Statistics Survey, 1994 to 1997,” *National Council on Pet Population Study and Policy*, Internet Archive, <https://web.archive.org/web/20150116060730/http://www.petpopulation.org/statsurvey.html>; Wenstrup and Dowidchuk, “Pet Overpopulation,” 310.

⁵⁷ “Animal Shelter Euthanasia,” *American Humane Association*, accessed May 3, 2017, <http://www.americanhumane.org/animals/stop-animal-abuse/fact-sheets/animal-shelter-euthanasia.html>.

⁵⁸ Wenstrup and Dowidchuk, “Pet Overpopulation,” 310, table 6.

⁵⁹ Wyler, “Animal Control,” 28.

adopt could be seen as optional. Because of the relatively low pay and difficult work, hiring qualified shelter staff was sometimes a challenge.⁶⁰ Shelters run by a city or a county often had a higher wage scale and better benefits than shelters run by private humane societies, but the overall pay scale in sheltering was low.



Figure 19:
Phyllis Wright with HSUS President Oliver Evans. Reprinted with permission from The Humane Society of the United States.

A shelter director remarked at a 1974 conference that until recently the main considerations in hiring animal control officers had been whether they were “over the age of 21 years, in reasonable physical condition and willing to work for very little money.”⁶¹ According to this official, shelter management jobs were so low in status that directors did not “want their best friends to know they are directing an animal control agency.”⁶² The usual practice in filling management jobs at a shelter was simply to appoint people from within the organization.⁶³ Another shelter director noted at a 1976 conference that sometimes the animal shelter was a convenient place to get demoted police officers out of the way.⁶⁴

Phyllis Wright, of HSUS, ran a program in the 1970s and 1980s that was designed to help municipal shelters keep up with best practices.⁶⁵ Wright had worked in animal sheltering before joining HSUS in 1969, and one of her primary goals was to reach out to substandard shelters and help them professionalize their operations.⁶⁶ She traveled around the country holding workshops that taught fundamental aspects of good shelter management.⁶⁷ These meetings also provided a way for shelter workers and officials in a region to get to know each other.⁶⁸

Wright was especially concerned with promoting humane shelter practices, and she campaigned against inhumane methods of shelter killing like the decompression chamber and the use of hot, unfiltered vehicle exhaust in gas chambers.⁶⁹ She did not mince words. When she visited North Carolina in 1976, for example, she commented that one facility was “not fit for a dog.”⁷⁰ She noted that in all 18 of the states she had visited in the preceding year “animal control is still below garbage pick-up” as a priority for local officials,

⁶⁰ “Conclusions and Recommendations: Animal Control Officer Training,” in *Proceedings of the National Conference on Dog and Cat Control*, 268–270.

⁶¹ Robert Rush, “Problems of Regulation and Enforcement,” in *Proceedings of the National Conference on the Ecology of the Surplus Dog and Cat Problem*, 43.

⁶² *Ibid.*, 42.

⁶³ *Ibid.*, 42–43.

⁶⁴ Morse, “Common Goals,” 153.

⁶⁵ Unti, *Protecting All Animals*, 86–89.

⁶⁶ “Key NHEC Post Goes to Maryland Leader,” *News of the Humane Society of the United States* 14, no. 1 (January-February 1969): 3, http://animalstudiesrepository.org/v14_news/5; Unti, *Protecting All Animals*, 90–91.

⁶⁷ Unti, *Protecting All Animals*, 92–93; Katina Antoniadis, “The HSUS is Turning 50!,” *Animal Sheltering*, January-February 2004, 26. Many of the workshops were held at annual meetings of state or regional federations of humane societies. Carter Luke, interview by author, April 30, 2014.

⁶⁸ “77 is Banner Year for HSUS Workshop Program,” *Humane Society News* 22, no. 3 (Fall 1977): 18, http://animalstudiesrepository.org/v22_news/2.

⁶⁹ Unti, *Protecting All Animals*, 97–98.

⁷⁰ “HSUS’s Phyllis Wright Explains the Right Way,” *Humane Society News* 21, no. 3 (Summer/Fall 1976): 12, http://animalstudiesrepository.org/v21_news/1.

and said that the practice of local governments foisting off animal control on private humane societies without paying the cost had to stop.

On the 1976 trip to North Carolina, Wright criticized a county dog pound for, among other things, allowing two injured dogs to suffer for several days without treatment.⁷¹ She succeeded in getting county officials to make changes, including switching from using hot car exhaust as a killing method to euthanasia by injection. Shelter workers in many of the places she visited, far from resenting her criticisms, welcomed her help in bringing about changes in shelter funding and operations.

In addition to the traveling workshops that were designed to help shelter staff improve their practices, HSUS investigators helped citizens take action when their local pounds were treating animals cruelly and were not interested in reforming. The investigators, including Wright, would provide support to local groups for the time-consuming process of first documenting the cruelty and then working through solutions with city and county officials, with legal action as a last resort when nothing else succeeded.⁷²

In 1978, Wright started HSUS's *Shelter Sense* magazine as a way of getting information to shelters that could not afford to send their staff to conferences.⁷³ In 1996, *Shelter Sense* became *Animal Sheltering*, a magazine that is still published today.⁷⁴ Barbara Cassidy, Wright's successor, kept up the tradition of outreach to local shelters. She said at a 1987 conference that she visited 25 to 30 shelters each year.⁷⁵ The American Humane Association (AHA) was also involved in the effort to improve training, offering programs at various venues for shelter workers and animal control officers.⁷⁶

Although animal control is often seen as a low status job by the public and by city officials, it requires a variety of skills.⁷⁷ The job of an animal control officer can include responding to complaints about barking dogs, teaching humane education classes, dealing with dog bites, and investigating cases of animal cruelty.⁷⁸ Animal control officers are often granted limited police powers to enforce animal ordinances.⁷⁹ They have to know the animal control codes, how to issue citations (which requires knowing something about public relations), how to preserve evidence and prepare cases for court and testify if needed, and how to inspect facilities that require licensing. They are called upon to recognize diseases, provide first aid for injuries, and capture and restrain animals.⁸⁰

Training for animal-control officers is complicated by the fact that the ordinances they enforce vary from place to place. Ordinances typically cover issues including animal cruelty and neglect, licensing, leashing, housing, tethering, and how nuisance cats are handled. Animal cruelty definitions are primarily matters of state law, which varies from one state to another.⁸¹ State anti-cruelty laws can differ in the types of animals

⁷¹ Ibid.

⁷² "HSUS Fights Cruelty in Pounds," paper 14 in *The Humane Society of the United States Close-Up Report* (March 1978), http://animalstudiesrepository.org/cu_reps/14.

⁷³ Nancy Lawson, "Animal Sheltering: Celebrating 25 Years of Progress," *Animal Sheltering*, January 1, 2004.

⁷⁴ Ibid.

⁷⁵ Barbara Cassidy, "Responsibilities of Shelters," panel discussion in *Overpopulation of Cats and Dogs*, 97.

⁷⁶ Armstrong, Tomasello, and Hunter, "From Pets to Companion Animals," 72; Stephen Zawistowski and Julie Morris, "Introduction to Animal Sheltering," in *Shelter Medicine for Veterinarians and Staff*, 2nd ed., ed. Lila Miller and Stephen Zawistowski (Ames, IA: Wiley-Blackwell, 2013), 5.

⁷⁷ Morse, "Common Goals," 153; E.V. Hughey, "Animal Control," in *Achieving Humanitarian Aims: Our Commitment—The American Humane Association 95th Annual Meeting, October 17–21, 1971* (Denver: American Humane Association, 1971), 29–31.

⁷⁸ Rush, "Problems of Regulation and Enforcement," 41.

⁷⁹ Thomas Darneal, "Problems in Enforcement and Prosecution," in *Proceedings of the National Conference on Dog and Cat Control*, 194–198.

⁸⁰ William Dieterich, "Guidelines for In-Service Training of Animal Control Officers," in *Proceedings of the National Conference on Dog and Cat Control*, 144–145.

⁸¹ Susan Hunter and Richard Brisbin, Jr., *Pet Politics: The Political and Legal Lives of Cats, Dogs, and Horses in Canada and the United States* (West Lafayette, IN: Purdue University Press, 2016), 180–183; Randall Lockwood, "Reporting Cruelty in the United States," in *The Global Guide to Animal Protection*, ed. Andrew Linzey (Urbana: University of Illinois Press, 2013), 279–280.

covered, the types of acts that are considered animal cruelty, the definition of neglect, and whether neglect is criminalized.⁸² Training that is developed for one city or state therefore cannot just be transplanted to another.

In spite of the demands of the job, training for animal control officers up until the 1970s, and even later in many places, was generally either non-existent or of poor quality.⁸³ Animal control officers who had not been trained in the basics of the job were sometimes the cause of bad publicity, as in one case in the 1970s where officers were shown on television rounding up dogs and improperly carrying them by the nooses of their control sticks.⁸⁴ When Orange County, California, developed its training course for animal-control officers in the 1970s it found that there was so much to cover that the program required 200 hours of instruction time.⁸⁵

Animal control officers did not have their own national organization until the National Animal Control Association (NACA) was formed in 1978.⁸⁶ State associations for animal control officers were also slow to form. For example, at the time that Texas A&M began to develop an animal control training program in 1974, there was no state organization in Texas for animal control officers (one was formed in conjunction with the training program) and no listing of who had the responsibility for animal control in each city in the state.⁸⁷ Today, NACA (now the National Animal Care and Control Association, but still known as NACA) provides training for animal control officers and publishes a handbook.⁸⁸

Shelter managers, like animal control officers, suffered from a lack of resources for professional development. As Bernard Unti of HSUS put it: “The need for training is undeniable—an animal shelter is a complex operation. It’s a social institution, it often has political and legal authority, licensing and regulatory and enforcement authority; it’s herd medicine, there’s obviously a serious medical, veterinary, public health nexus; and there’s an educational mission—there’s a lot of things that are associated with it.”⁸⁹ One of the places where animal shelter administrators could find guidance was the Society of Animal Welfare Administrators (SAWA), formed in 1970.⁹⁰ SAWA has conferences for animal shelter administrators that provide professional development opportunities.⁹¹

⁸² Lockwood, “Reporting Cruelty,” 279–280.

⁸³ Rush, “Problems of Regulation and Enforcement,” 44.

⁸⁴ Morse, “Common Goals,” 154–155.

⁸⁵ Dieterich, “Guidelines for In-Service Training,” 146.

⁸⁶ “About NACA,” *National Animal Care & Control Association*, accessed April 8, 2017, <http://www.nacanet.org/?page=AboutNACA>.

⁸⁷ Bill Blackwell, “Designing an Animal Control Officers Training Program,” in *Proceedings of the National Conference on Dog and Cat Control*.

⁸⁸ “NACA Guidelines,” *National Animal Care & Control Association*, accessed April 8, 2017, http://c.ymcdn.com/sites/www.nacanet.org/resource/resmgr/Docs/NACA_Guidelines.pdf.

⁸⁹ Bernard Unti, interview by author, March 6, 2015, and e-mail to author, August 2, 2016.

⁹⁰ “History,” *Society of Animal Welfare Administrators*, accessed April 8, <http://www.sawanetwork.org/history.html>.

⁹¹ “Statement of Purpose,” *Society of Animal Welfare Administrators*, accessed April 8, <http://www.sawanetwork.org/statement-of-purpose.html>.

Part II: The First Era of Sheltering
Chapter 5: Shelter Operations in the 20th Century

A consistent practice of most shelters nationwide from the time the first shelter was founded in 1870 throughout the 1900s was killing a high percentage of the animals who were impounded. An AHA official estimated in 1974 that public shelters were killing 90% of their intake on average.⁹² By the year 2000, various estimates placed shelter killing at around 65% to 75% of intake. These high rates of killing were due to several factors, including an imbalance between intake and the number of potential homes available for shelter animals. The issue of pet overpopulation became prominent in the 1970s, but before that there were controversies, discussed in the following two chapters, that would call attention to shelter killing and help set the stage for change.

⁹² Rutherford Phillips, "Problems of Euthanasia and Adoption," in Proceedings of the National Conference on the Ecology of the Surplus Dog and Cat Problem, 52.

Chapter 6: Death at the Shelter

The outcome for most dogs and cats who entered animal shelters in the United States in the 20th century was death. According to an estimate made by the director of the American Humane Association (AHA) in 1974, shelters nationwide were killing 90% of the animals they took in.¹ This high rate of shelter deaths did not apply just to municipal shelters. A researcher who studied shelters in California in the 1970s found that, contrary to popular belief, there was little difference in operations between private shelters that had contracts to run city shelters and shelters that were entirely run by city employees. The ASPCA, in the years from 1894 to 1994 when it held the animal control contract for New York City, killed a high of 98% of its intake in 1934 and a low of 77% in 1994.²

Shelter killing in the United States was accepted as a necessity and largely unquestioned until the latter decades of the 20th century. It appears that the number of homeless cats and dogs exceeded the number of available homes until late in the 20th century. The pet overpopulation crisis that was recognized in the early 1970s and the ensuing extensive campaign to reduce the number of homeless pets is discussed in Part III of the book. That campaign had a significant effect, and shelter intake nationwide plunged in the years from 1970 to 2000 and has continued to decline since then at a slower rate. This chapter looks at how shelters dealt with the situation they faced during the years of pet overpopulation.

As discussed in Chapter 9, spaying shelter animals was not practical before the 1970s at the earliest. Spaying (surgical sterilization of the female animal) is major abdominal surgery and is more time consuming and expensive than castration (surgical sterilization of the male animal). The cost of routine spaying put it beyond the means of most shelters. It was common until at least the 1970s for people to allow pets to roam freely,³ and shelter workers were faced with the fact that an adoption of an unsterilized female dog or cat, while it would save one life, would likely result in many more homeless pets being born. As a result, many shelters were reluctant to adopt out female cats and dogs.

In the early 1900s, some shelters, such as the Animal Rescue League of Boston and the ASPCA, allowed the adoption of castrated male cats, but killed female cats.⁴ A 1913 newspaper human interest story about a puppy at the Boston shelter said that she was “under sentence of death . . . because [she] was a female.”⁵ This policy or variations on it was common up until the 1970s, and even beyond in some places. One director of a humane society shelter remarked at a 1971 conference: “As do so many other societies, we hesitate before placing an unspayed female.”⁶ As late as 1975, the San Francisco SPCA still had a policy of killing females rather than adopting them out.⁷

¹ Rutherford Phillips, “Problems of Euthanasia and Adoption,” in *Proceedings of the National Conference on the Ecology of the Surplus Dog and Cat Problem, May 21–23, 1974* (Denver: American Humane Association, 1974), 52. Another shelter official put the figure somewhat lower, at 80%, in 1979. Richard Marshall, “The United States of America Conferences,” chap. 10 in *The Handbook of Animal Welfare: Biomedical, Psychological, and Ecological Aspects of Pet Problems and Control*, ed. Robert Allen and William Westbrook (New York: Garland STPM Press, 1979), 120.

² Stephen Zawistowski et al., “Population Dynamics, Overpopulation, and the Welfare of Companion Animals: New Insights on Old and New Data,” *Journal of Applied Animal Welfare Science* 1, no. 3 (1998): 202, table 4, doi:10.1207/s15327604jaws0103_1.

³ Katherine Grier, *Pets in America: A History* (Chapel Hill: University of North Carolina Press, 2006), 62; Paul Irwin, “Overview: The State of Animals in 2001,” in *The State of the Animals: 2001*, ed. Deborah Salem and Andrew Rowan (Washington, DC: Humane Society Press, 2001), 2. Flea control was difficult, which meant pets were often banished to the outdoors, at least during the summer and fall while flea populations were high. Grier, *Pets in America*, 60, 63, 85–87.

⁴ Bernard Unti, “The Quality of Mercy: Organized Animal Protection in the United States, 1866–1930” (PhD diss., American University, 2002), 507.

⁵ “Hundreds Strive to Make Home for Susie,” *Boston Post*, April 1, 1913.

⁶ Frank Rogers, “Spaying as an Answer,” in *Achieving Humanitarian Aims: Our Commitment—The American Humane Association 95th Annual Meeting, October 17–21, 1971* (Denver: American Humane Association, 1971), 137.

⁷ Richard Avanzino, interviews by author, July 23, 2014, August 15, 2014, and March 3, 2015.

Another tactic used by shelters to mitigate the possibility of adopted animals reproducing was to have highly selective adoption policies. The shelter industry in the 1970s saw selective adoption standards as part of a comprehensive plan to control the pet overpopulation problem.⁸ Since the late 1990s, shelters have been steadily moving away from strict adoption policies, and people today often wonder why such policies were ever thought to be a good idea. One reason was that in the days when shelters were not able to spay and neuter any significant portion of their animals, shelter managers believed that their only defense against adopted animals producing more puppies and kittens was finding owners who were responsible enough to keep their pets confined. This rationale makes some of the common adoption requirements, like a fenced yard for dogs and keeping cats indoors, easier to understand.

In addition to the fact that shelter killing took breeding animals out of the population, some humane advocates accepted shelter killing because they considered homeless dogs and cats to be living miserable lives. As one journalist put it in 1907, homeless animals had “an existence that can be no joy to them and of no benefit to anybody.”⁹ Shelter personnel thought that the only alternative to killing would be to leave the animals in the street, where they would be struck by cars, starve, die of exposure or disease, or be subjected to deliberate cruelty. Trying to attract people into the shelter to adopt, at a time when puppies and kittens were widely available for free from their coworkers, neighbors, and family, was not seen as a realistic solution.

The attitude of early humane leaders like Henry Bergh, Caroline Earle White, and George Angell about shelter killing was pragmatic, notwithstanding statements they made about the rights of animals. Caroline Earle White once said that “animals have certain rights, as inalienable as those of man to life, liberty and the pursuit of happiness.”¹⁰ She was a vegetarian and refused to wear fur coats or the ubiquitous women’s hats decorated with feathers from wild birds.¹¹ Yet the shelter she managed killed many healthy animals. Henry Bergh wrote a “Declaration of the Rights of Animals,”¹² and referred to “rights” granted to animals by the “Great Creator.”¹³ Yet he also stated: “Kill, if necessary, but torture not, is the command of intelligent reason.”¹⁴ He unsuccessfully asked the New York City mayor and aldermen to build a shelter along the lines of White’s dog shelter in Philadelphia, to be managed by the ASPCA, where dogs and cats could be killed humanely.¹⁵ George Angell, the dedicated advocate of kindness to animals and humane education, supported the establishment of the Animal Rescue League of Boston, which killed most of the animals it took in.¹⁶

Shelters had great difficulty with the mechanics of killing. As discussed in Part I, city pounds in the 1800s typically used drowning, clubbing, and poisons to kill animals. When humane organizations began to take over city pounds in the latter decades of the 1800s in order to run them more humanely, one of their goals was to find a way to kill animals that would not frighten them or cause pain, would be fast enough to allow workers to get through the day’s killing, would be cheap enough to allow the shelter to pay for it, and would

⁸ Marshall, “The United States of America Conferences,” 120–121.

⁹ “Learn the New Dog Law,” *Philadelphia Inquirer*, June 8, 1907.

¹⁰ Diane Beers, *For the Prevention of Cruelty: The History and Legacy of Animal Rights Activism in the United States* (Athens, OH: Ohio University Press/Swallow Press, 2006), 47.

¹¹ *Ibid.*

¹² *Ibid.*, 43.

¹³ Sydney Coleman, *Humane Society Leaders in America* (Albany, NY: American Humane Association, 1924), 43.

¹⁴ *Ibid.*, 53.

¹⁵ See chapter 3.

¹⁶ “Future of Cats,” *Boston Sunday Post*, January 29, 1899.

not stress or disgust everyone so much that it was intolerable.¹⁷ It turned out to be very hard to find such a method.

Chloroform was one of the earliest methods used for “humane” killing of homeless animals, starting in the mid-1800s. It could be placed on a cloth and held over the animal’s nose and mouth or used in a chamber.¹⁸ Among its disadvantages was that animals sometimes struggled fiercely when they smelled it.¹⁹ Poisons administered by mouth were used to kill homeless animals in some places, but even fast-acting poisons caused pain. Shooting animals was considered humane (as it still is today in some circumstances, such as field emergencies²⁰), but shooting is loud, traumatic, can be dangerous to bystanders, and must be done precisely in order to be effective. The AHA’s 1904 paperback edition of the novel *Black Beauty* had diagrams for shooting horses and dogs for a quick death.²¹ Electrocutation was used in some shelters in the early 1900s, but people eventually realized that it was not painless, and it fell out of favor by 1930.²² A modified method of electrocutation was promoted by the Humane Society of the United States (HSUS) in the 1960s, but that too was abandoned.²³

Gassing—introducing a gas such as carbon monoxide into a sealed chamber with one or more animals—used to be a common method of shelter killing but is no longer recommended.²⁴ Like electrocutation, gassing was initially thought to be painless and humane. Gassing can lead to a prolonged and stressful death, though, especially if the chamber is not constructed, maintained, and used correctly.²⁵ Chambers are subject to both equipment and operator malfunctions, and having to import gas into the chambers is cumbersome. In the mid-1900s it was common for shelters to vent unfiltered, hot exhaust from a vehicle into a compartment where the animals were placed.²⁶ Needless to say, this was clumsy and dangerous as well as inhumane.

There have been reports of shelter workers being sickened and killed by carbon monoxide exposure, and chronic exposure to even low levels of gas is dangerous.²⁷ In addition to the practical problems with gassing, many members of the public are repelled by the idea of using chambers to gas animals to death.²⁸ The problems with gassing have led to a sharp decline in the number of shelters using that method, and HSUS has reported that as of July 2016, only four states still had shelters where use of a gas chamber was confirmed or suspected.²⁹

¹⁷ The AVMA euthanasia guidelines for 2013 list 14 criteria for gauging the acceptability of euthanasia methods, indicating the difficulty of finding a perfect method. *AVMA Guidelines for the Euthanasia of Animals: 2013 Edition* (Schaumburg, IL: American Veterinary Medical Association, 2013), 10, accessed April 10, 2017, <https://www.avma.org/kb/policies/documents/euthanasia.pdf>.

¹⁸ The ASPCA used a chloroform chamber in the late 1800s. Marion Lane and Stephen Zawistowski, *Heritage of Care: The American Society for the Prevention of Cruelty to Animals* (Westport, CT: Praeger, 2008), 32.

¹⁹ J. Fred Smithcors, *The American Veterinary Profession: Its Background and Development* (Ames: Iowa State University Press, 1963), 186.

²⁰ AVMA Guidelines for the Euthanasia of Animals, 36–38.

²¹ Grier, *Pets in America*, 104.

²² Unti, “Quality of Mercy,” 488–491.

²³ Bernard Unti, *Protecting All Animals: A Fifty-Year History of the Humane Society of the United States* (Washington, DC: Humane Society Press, 2004), 88–89. The use of an “electrocution box” by a “city pound” was mentioned at a 1971 American Humane Association conference. “Personal Communication,” in *Achieving Humanitarian Aims*, 94.

²⁴ Martha Smith-Blackmore, “Euthanasia,” chap. 30 in *Shelter Medicine for Veterinarians and Staff*, 2nd ed., ed. Lila Miller and Stephen Zawistowski (Ames, IA: Wiley-Blackwell, 2013), 476–477.

²⁵ *Ibid.*

²⁶ Unti, *Protecting All Animals*, 97; Douglas Fakkema, interview by author, May 14, 2015.

²⁷ Smith-Blackmore, “Euthanasia,” 476.

²⁸ Gordon Robinson, “Euthanasia: Agents Used; Public Perception; Stress on Technicians,” in *Overpopulation of Cats and Dogs: Causes, Effects, and Prevention*, ed. Marjorie Anchel (New York: Fordham University Press, 1990), 79.

²⁹ “Gas Chambers: Current Landscape,” *Humane Society of the United States*, accessed April 10, 2017, <https://www.animalsheltering.org/sites/default/files/content/gas-chamber-map-july-2016.pdf>.

“Decompression” chambers—chambers that mimicked the effect of high altitude decompression in airplanes—were introduced as a method of shelter killing after World War II and were used until the 1980s.³⁰ While gassing operates by adding a gas to the chamber that prevents the animal’s body from getting enough oxygen to maintain life, decompression operated by removing the air from the chamber using a vacuum pump.³¹ Pilots at high altitude experience decompression when their planes lose cabin pressure. As the level of oxygen saturation in their blood decreases, they can lose consciousness and die. Some pilots who experienced a relatively slow decompression and survived reported euphoria and a lack of any realization of what was happening to them.³² These reports were the basis for the shelter industry adopting decompression as a method of killing.

Decompression was popular with shelter managers because it was easier for shelter workers to use than gas chambers and did not require dangerous gasses.³³ It was a common method of shelter killing in the 1960s and 1970s, at least in larger shelters. Decompression chambers were metal cylinders that looked like trash cans turned on their sides and placed on carts.³⁴ These “Euthanair”³⁵ chambers were available in different sizes, and the large ones could accommodate several animals per cycle.³⁶ Animals were put in cages on wheels and rolled inside the chamber. After the machine had gone through its cycle the dead animals were rolled out. This could be repeated throughout the day.

In spite of the theory that the decompression process provided a humane death, horror stories about decompression became common.³⁷ When decompression is too rapid, it results in the extremely painful condition which divers refer to as “the bends.” Rapid decompression also causes air to rush from the lungs, which sometimes made animals panic. There were reports that decompression chambers could cause intense inner ear or lung pain, and that it was slow to kill puppies and kittens, causing them excruciating organ pain and a prolonged death.³⁸

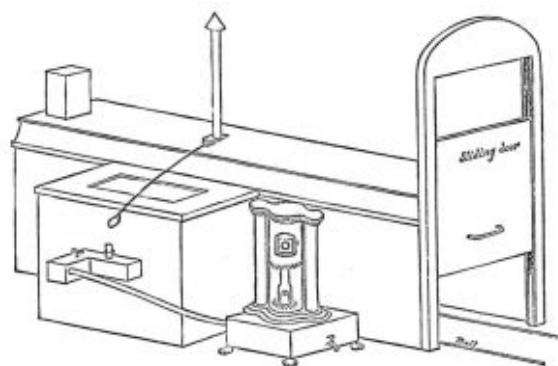

Figure 20:
A British medical doctor, Benjamin Ward Richardson, designed this “lethal chamber” for the Battersea Dog’s Home, circa 1884. He tested 22 anesthetic agents to find the least painful one, and settled on carbon monoxide (carbonic oxide). Public domain.

³⁰ Lane and Zawistowski, *Heritage of Care*, 41; Nona Hengen, *In Pursuit of Compassion: A Centennial History of the Spokane Humane Society, 1897–1997* (Spokane, WA: Spokane Humane Society, 1997), 356–358; Martha Armstrong, Susan Tomasello, and Christyna Hunter, “From Pets to Companion Animals,” in *State of the Animals: 2001*, 79. A 1958 article listed 13 cities, mostly in California but including New York, Chicago, and Denver, that were using the decompression chamber for shelter killing. Russell Schelkopf, “The Application of Certain Methods for the Determination of the Presence of Pain in the Dog During Decompression,” paper 1653 in *Iowa State University Digital Repository: Retrospective Theses and Dissertations* (1958): 1, <http://lib.dr.iastate.edu/cgi/viewcontent.cgi?article=2652&context=rtid>.

³¹ Lane and Zawistowski, *Heritage of Care*, 41; Unti, *Protecting All Animals*, 97–98.

³² Linda Pendleton, “When Humans Fly High: What Pilots Should Know About High-Altitude Physiology, Hypoxia, and Rapid Decompression,” *AV Web*, November 7, 1999, <http://www.avweb.com/news/aeromed/181893-1.html?redirected=1>; Rutherford Phillips, “Animal Welfare Problems in the 1970s (AHA Executive Director’s Annual Report),” in *Achieving Humanitarian Aims*, 12.

³³ Schelkopf, “Application of Certain Methods,” 1–2.

³⁴ Avanzino, interviews; William Peterson, “An Animal Control Officer’s Story: From Enforcer to Educator,” *Between the Species* 2, no. 4 (Fall 1986): 204, doi:10.15368/bts.1986v2n4.10.

³⁵ The company’s name was sometimes misspelled as “Euthanaire.” The machines were manufactured by the Euthanair Engineering and Sales Company, headquartered in Los Angeles, California. Schelkopf, “The Application of Certain Methods,” 2n1.

³⁶ Douglas Fakkema, who saw many decompression chambers in his visits to shelters over the years, said that the largest model he had seen was about five feet in diameter, with a small satellite unit that was big enough for a cat cage. The chambers were sturdy tanks made of heavy, galvanized steel with rubber seals on the doors. Douglas Fakkema, interview.

³⁷ See, e.g., Peterson, “An Animal Control Officer’s Story,” 204–205.

³⁸ Christine Stevens, “Dogs,” chap. 6 in *Animals and Their Legal Rights: A Survey of American Laws from 1641 to 1990*, 4th ed. (Washington, DC: Animal Welfare Institute, 1990), 119.

By the 1970s, a grassroots movement was working against the use of the decompression chamber.³⁹ Local activists stole the compressor for a Euthanair machine from a humane society in Florida in 1971.⁴⁰ In 1972, Frederick “Doc” Thomsen, who wrote a newsletter called Report to Humanitarians, did an in-depth study of the available findings about decompression and concluded that the likelihood of intense pain from decompression, even if the pain lasted only a short time, made it an unacceptable method for killing an animal.⁴¹ Richard Avanzino removed the San Francisco SPCA’s decompression chamber, which was the largest one in California at the time, when he took over as SPCA president in 1976.⁴² In 1978, the ASPCA, under new president John Kullberg, changed the ASPCA’s method of shelter killing from the decompression chamber to injection of drugs.⁴³ Prominent humane experts like Phyllis Wright and veterinarian Michael W. Fox testified before state legislatures in support of laws to ban decompression chambers.⁴⁴



Figure 21:
Navy diver monitors a decompression chamber used to help divers avoid “the bends.” The attempt by the shelter industry to use decompression technology for killing shelter animals was ill-advised and took years to stamp out. Public domain.

The American Veterinary Medical Association (AVMA) periodically issues reports from its panel on euthanasia that state its views on acceptable and unacceptable methods of euthanasia. Its opinion about decompression fluctuated in the 1960s and 1970s, but by the time of its 1986 report it listed decompression as “not a recommended method,” along with a devastating critique of the procedure.⁴⁵ The 1986 report listed seven disadvantages of decompression, including: “Commonly used chambers are designed to produce decompression at a rate 15 to 60 times faster than that recommended as optimum for animals.”⁴⁶ By 1990, over half of the states had bans on the use of decompression chambers, and the Euthanair company was out of

business.⁴⁷ The battle over decompression was one factor in re-energizing the humane movement, which had fallen into a period of stasis after World War I.

As decompression and the gas chamber fell from favor, more and more shelters adopted the technique of euthanasia by injection, or EBI. This technique uses an overdose of an injected chemical, usually sodium pentobarbital, to cause rapid unconsciousness and death.⁴⁸ Injection of the chemical is usually done

³⁹ Lane and Zawistowski, *Heritage of Care*, 41; Unti, *Protecting All Animals*, 98.

⁴⁰ “Charges Dropped for Pet Execution Machine Thefts,” *Naples Daily News*, January 23, 1972; Unti, *Protecting All Animals*, 98.

⁴¹ Unti, *Protecting All Animals*, 8–9, 98.

⁴² Avanzino, interviews.

⁴³ Lane and Zawistowski, *Heritage of Care*, 42–43.

⁴⁴ Sheila Walsh, “Phyllis Wright: The Woman Who Gave Shelters and Their Animals More Dignity,” *Humane Society of the United States*, June 4, 2004, <http://www.hsus.org/ace/20506>; Unti, *Protecting All Animals*, 98.

⁴⁵ American Veterinary Medical Association, “Report of the AVMA Panel on Euthanasia,” appendix in *Euthanasia of the Companion Animal: The Impact on Pet Owners Veterinarians, and Society*, ed. William Kay et al. (Philadelphia: Charles Press, 1988), 257–258.

⁴⁶ *Ibid.*, 258.

⁴⁷ “States Prohibiting the Use of the High-Altitude Decompression Chamber,” in *Animals and Their Legal Rights*, 420–421; Armstrong, Tomasello, and Hunter, “From Pets to Companion Animals,” 79.

⁴⁸ Smith-Blackmore, “Euthanasia,” 477–479.

intravenously today. Training in using EBI is essential, since improper techniques can be painful to the animal and lead to complications.⁴⁹ Training and certification methods for euthanasia technicians are regulated at the state level and vary widely.⁵⁰

Some shelter managers resisted switching to EBI, believing that it would be too expensive, or that the paperwork required for using sodium pentobarbital would be burdensome because it is a controlled substance. Some were concerned that shelter workers would be in danger when performing EBI on feral or wild animals. As people gained experience with EBI, though, those issues proved to be manageable.

One advantage of EBI is that it can be done in a way that does not alarm the animal. In fact, many people feel that EBI is the least emotionally stressful euthanasia method for both animals and the shelter workers who perform the procedure. Although EBI is not a perfect method for ending the life of an animal, since technical difficulties with the procedure can happen, it is currently accepted as the best of the available methods.⁵¹ The Association of Shelter Veterinarians, ASPCA, HSUS, and AHA recommend EBI using sodium pentobarbital for euthanasia of shelter dogs and cats.⁵² The AVMA's 2013 euthanasia guidelines state that EBI is the preferred method for shelter and rescue facilities.⁵³

In the 1980s, the animal rights movement, along with other developments, raised new challenges to shelter killing, and pressure increased for shelters to release more animals alive. The very difficult ethical and practical issues those developments raised for shelter workers are discussed in chapter 18.

⁴⁹ Ibid., 479–480; *Euthanasia Reference Manual*, 2nd ed. (n.p.: Humane Society of the United States, 2013), 7–29, 94.

⁵⁰ Smith-Blackmore, "Euthanasia," 471.

⁵¹ *Euthanasia Reference Manual*, 2.

⁵² Smith-Blackmore, "Euthanasia," 477.

⁵³ AVMA Guidelines for the Euthanasia of Animals, 47.

Chapter 7: Pound Seizure

The dog pounds that cities in the United States established in increasing numbers starting in the mid-1800s were a convenient source of laboratory animals for medical doctors and scientists. Pounds—and later shelters—had a constantly renewed supply of ownerless dogs and cats whom researchers could acquire at little or no cost. This practice was the cause of a running battle between humane advocates and researchers that lasted for over 100 years.

Researchers who experimented on animals were known as “vivisectionists” in the 1800s and into the mid-1900s because they generally conducted their experiments on live, unanesthetized animals. This was partly because the anesthetics of the day were inconvenient, dangerous, and unpredictable, and partly because



Figure 23:
C.H. Best & F.G. Banting in 1921. Banting was one of two researchers who received the Nobel Prize in Medicine in 1923 for the discovery of insulin. The dog is an experimental subject, ID #408. From the Thomas Fisher Rare Book Library, license CC BY 2.0.

scientists largely discounted animal pain.¹

An anti-vivisection movement in the United States gained

many adherents in the late 1800s, but when its early leaders died the movement stagnated. Caroline Earle White, who founded the American Anti-Vivisection Society (AAVS) in 1883,² and Albert Leffingwell, another prominent leader of the early anti-vivisection movement, both died in 1916. By 1920, the AAVS was down to a few hundred members and the movement’s legislative proposals were routinely defeated.³ Meanwhile, public approval of animal research was growing due to some dramatically effective treatments that resulted from experiments on animals. The use of dogs was key in experiments that led to the development of insulin, the mainstay of treatment for diabetes. Researchers created diabetic dogs by removing their pancreases and then demonstrated that the dogs could be kept healthy by injections of insulin. Injections of insulin were first tried on a human being in 1922. The subject was a 14-year old diabetic boy who was near death, and he made a full recovery after receiving insulin. Two scientists who had carried out the experiments on dogs to discover insulin received the Nobel prize for medicine in 1923.⁴



Figure 22:
Dr. Albert Leffingwell. Public domain.

¹ Bernard Rollin, “Animal Pain,” in *The Global Guide to Animal Protection*, ed. Andrew Linzey (Urbana: University of Illinois Press, 2013), 256–257.

² Sydney Coleman, *Humane Society Leaders in America* (Albany, NY: American Humane Association, 1924), 204–205.

³ Bernard Unti, “The Quality of Mercy: Organized Animal Protection in the United States, 1866–1930” (PhD diss., American University, 2002), 658–660; Susan Lederer, “Political Animals: The Shaping of Biomedical Research Literature in Twentieth-Century America,” *Isis* 83, no. 1 (March 1992): 62–63, doi:10.1086/356025.

⁴ Robert Dunlop and David Williams, *Veterinary Medicine: An Illustrated History* (St. Louis: Mosby, 1996), 601; “The Discovery of Insulin,” *Nobel Prize*, accessed April 11, 2017, <http://www.nobelprize.org/educational/medicine/insulin/discovery-insulin.html>.

Animal experimentation received much favorable publicity in the years after the development of insulin, but there was unfavorable publicity too. William Randolph Hearst, the newspaper magnate, employed several journalists to report on the many cases of stolen pets winding up in research laboratories.⁵ The research industry could have taken steps to discourage animal dealers from supplying it with stolen pets, but it did not do so effectively and therefore continued to have damaging publicity.

Another public relations problem for the industry was researchers who mocked and belittled concerns about animal use. James Warbasse, a medical doctor, argued in a 1910 book that some women who opposed animal experimentation were obsessed with dogs to the point of mental illness.⁶ An editor of a prominent research journal once referred to anti-vivisectionists as “ignorant fanatics.”⁷ In the 1960s, researchers called animal advocates “humaniacs.”⁸ During a time when there were regular reports of horrifically painful experiments performed in laboratories on conscious animals, including dogs, cats, and apes, this scorn for humane concerns left researchers open to charges that they were cruel and unfeeling.

Medical and scientific research in the United States ramped up sharply after 1945 due to generous post-war federal funding, and researchers suddenly found themselves needing many more animals for experimentation.⁹ It was natural for researchers to think of public animal shelters as part of the answer to their need for more dogs and cats, because researchers had been taking smaller numbers of animals from pounds for so many years. The humane organizations that operated public animal shelters under contract in many cities were an obstacle, however. Despite the stagnation of the battle against vivisection at the national level, individual humane organizations still won some local battles. The Animal Rescue League of Boston, for example, successfully fought off efforts by medical schools to seize animals from its shelter in 1922.¹⁰

Scientists decided following World War II to solve the problem of local resistance by making a nationwide push to enact state laws that would compel pounds to supply animals for research. These state “pound seizure” laws would guarantee scientists a large, low cost supply of animals into the indefinite future, without having to fight humane organizations in each individual city. And researchers may have assumed that dogs and cats obtained from pounds were less likely to be stolen pets than those obtained elsewhere.

Scientists used many types of animals for their experiments in the post-World War II years, but for some types of experiments they preferred dogs. Dog anatomy was similar to human anatomy for purposes of some studies and for surgical training. Dogs were, for the most part, well socialized to people and were easy to handle and restrain. Unfortunately for researchers, the same social qualities that made dogs tractable experimental subjects made the public sympathize more with dogs than with many other types of laboratory animals.¹¹ Researchers thought that using dogs from pounds should neutralize some of this

⁵ Lederer, “Political Animals,” 63–64. After Hearst’s death in 1951 his son took over the Hearst publishing business but did not continue his father’s support of anti-vivisectionism.

⁶ James Warbasse, *The Conquest of Disease Through Animal Experimentation* (New York: D. Appleton, 1910), 158–161. The AAVS started out with participation by male physicians and clergy, but it quickly became predominantly female after many men left due to the movement’s stance in favor of abolition of vivisection rather than regulation. Craig Buettinger, “Women and Antivivisection in Late Nineteenth-Century America” *Journal of Social History* 30, no. 4 (Summer 1997): 858–859, doi:10.1353/jsh/30.4.857.

⁷ Lederer, “Political Animals,” 77.

⁸ Diane Beers, *For the Prevention of Cruelty: The History and Legacy of Animal Rights Activism in the United States* (Athens: Ohio University Press/Swallow Press, 2006), 176.

⁹ John Parascandola, “Physiology, Propaganda, and Pound Animals: Medical Research and Animal Welfare in Mid-Twentieth Century America,” *Journal of the History of Medicine and Allied Sciences* 62, no. 3 (July 2007): 279–280, doi:10.1093/jhmas/jrl060; Roger Pielke, Jr., “In Retrospect—Science: The Endless Frontier,” *Nature* 466 (August 2010): 922–923, doi:10.1038/466922a; Andrew Rowan and Franklin Loew, “Animal Research: A Review of Developments, 1950–2000,” in *The State of the Animals: 2001*, ed. Deborah Salem and Andrew Rowan (Washington, DC: Humane Society Press, 2001), 111.

¹⁰ “Animals Not for Doctors,” *Boston Post*, November 15, 1922.

¹¹ Lynda Birke, Arnold Arluke, and Mike Michael, *The Sacrifice: How Scientific Experiments Transform Animals and People* (West Lafayette, IN: Purdue University Press, 2007), 23–24.

sympathy, since the animals that pounds would turn over to researchers were destined to be killed anyway.¹²

The research industry's vehicle for fighting regulation of vivisection and pushing its new pound seizure strategy was an organization called the National Society for Medical Research (NSMR).¹³ NSMR began its work in 1946, and by October 1947, it had the backing of 226 member organizations.¹⁴ NSMR quickly began to advocate for state laws mandating pound seizure.

The first such state law was enacted in Minnesota in 1948.¹⁵ The bill was passed by the legislature and signed by the governor before the humane community was even aware that it had been proposed. The Minnesota law applied only to impounded animals from shelters that were publicly funded. The theory behind the law was that local governments owned the impounded homeless animals in their jurisdictions, at least after any mandatory holding period had expired, and the state could therefore order their disposition in any manner it wished.

The following year, a law was passed in Wisconsin with a broader scope. The Wisconsin law required that all shelters, not just tax supported ones, had to turn over homeless animals to scientific institutions on request.¹⁶ An Illinois proposal that was similar to the Wisconsin law was defeated in the state legislature, but laws similar to the less extreme Minnesota version were enacted by several other states.¹⁷ Some cities in states without pound seizure laws passed local ordinances mandating pound seizure.¹⁸ Pound seizure ordinances in Baltimore and Los Angeles passed by large margins.¹⁹

Pound seizure was a crisis for the organized animal protection movement, which was very deeply involved in animal sheltering. Many humane organizations had contracts with cities or counties to operate the local municipal animal shelter. These organizations had long ago accepted "euthanasia" as a necessary evil for the homeless animals in their care, but turning the animals over to laboratories for painful and sometimes torturous experiments was another thing entirely.²⁰ As Christine Stevens, one of the leading campaigners to regulate the use of animals in research put it, if shelters were forced to surrender their animals "the entire structure would lose its moral basis as a sanctuary for animals where they would be safe from inflicted suffering."²¹ Some shelters, such as the Maryland SPCA in Baltimore, discontinued contracts with cities that tried to force them to turn over animals for experimentation.²²

¹² Parascandola, "Physiology, Propaganda, and Pound Animals," 299–300.

¹³ *Ibid.*, 291–292.

¹⁴ *Ibid.*, 283–284.

¹⁵ Christine Stevens, "Laboratory Animal Welfare," chap. 4 in *Animals and Their Legal Rights: A Survey of American Laws from 1641 to 1990*, 4th ed. (Washington, DC: Animal Welfare Institute, 1990), 67.

¹⁶ *Ibid.*

¹⁷ *Ibid.*

¹⁸ Andrew Rowan, *Of Mice, Models, and Men: A Critical Evaluation of Animal Research* (Albany: State University of New York Press, 1984), 151.

¹⁹ *Ibid.*, 52–53, 150.

²⁰ Parascandola, "Physiology, Propaganda, and Pound Animals," 300.

²¹ Stevens, "Laboratory Animal Welfare," 67.

²² "Our History," *Maryland SPCA*, accessed April 11, 2017, <http://www.mdspca.org/about/history/>.

Municipalities soon began to realize that pound seizure could have a bad effect on animal control at a purely practical level. In some cases, the amount that researchers paid per animal was so low that it did not even pay the shelter's costs.²³ This meant that the local government or humane agency, in addition to being forced to turn over its animals, was also being forced to subsidize the biomedical community. Another problem with pound seizure was that people were less likely to cooperate with animal control officers if they knew that animals brought to the pound could be turned over to researchers.²⁴ When Los Angeles eventually banned pound seizure, it was reportedly in part because of concerns that the practice was making it harder for the city's shelter system to do its job.²⁵

The American Humane Association (AHA), a national umbrella group for humane organizations, made an attempt to have a dialogue with NSMR, but that attempt was unsuccessful.²⁶ The challenge that NSMR presented to the humane community was instrumental in the formation of two important new organizations in the early 1950s, the Animal Welfare Institute (AWI) in 1951 and the Humane Society of the United States (HSUS) in 1954.²⁷ Although both of these organizations had a broad animal-protection agenda, they were very active in fighting pound seizure.



Figure 24:
This townhouse was an early home for HSUS. Photograph reprinted with permission from *The Humane Society of the United States*.

Christine Stevens, who founded AWI and was its president until her death in 2002, was a pragmatic leader who was one of the most effective animal welfare advocates of the time.²⁸ AWI's goal as to animal research was not radical. Stevens wanted reasonable regulation of the industry, charting a middle course between anti-vivisectionists, who wanted abolition of animal research, and the research industry, which wanted no regulations at all.²⁹ As part of accomplishing the goal of regulation, AWI and other organizations publicized examples of painful and mutilating experiments conducted on animals without anesthesia or with inadequate anesthesia.

Christine Stevens' father, Robert Gesell, a professor of physiology at the University of Michigan who supported Stevens' efforts to regulate animal experimentation, observed that NSMR saw no difference between people who opposed all research on animals and people who merely wanted the use of animals

²³ John McArdle, "What's Wrong with Pound Seizure?," in *Overpopulation of Cats and Dogs: Causes, Effects, and Prevention*, ed. Marjorie Anchel (New York: Fordham University Press, 1990), 127.

²⁴ Elinor Molbegott, "Legislation: Past and Future," in *Overpopulation of Cats and Dogs*, 219.

²⁵ McArdle, "What's Wrong with Pound Seizure?," 125.

²⁶ Stevens, "Laboratory Animal Welfare," 67; Rowan, *Of Mice, Models, and Men*, 53; Bernard Unti, *Protecting All Animals: A Fifty-Year History of the Humane Society of the United States* (Washington, DC: Humane Society Press, 2004), 65.

²⁷ Rowan, *Of Mice, Models, and Men*, 53. The HSUS was originally named the National Humane Society. Unti, *Protecting All Animals*, 3.

²⁸ Wolfgang Saxon, "Christine Stevens, 84, A Friend to the Animals," *New York Times*, Oct. 15, 2002; Rowan, *Of Mice, Models, and Men*, 60.

²⁹ Parascandola, "Physiology, Propaganda, and Pound Animals," 293, 302–305. The AWI supported the "Three Rs" approach (replacement, reduction, and refinement), a program for reduction of animal use in research and amelioration of pain and distress. Martin Stevens, Alan Goldberg, and Andrew Rowan, "The First Forty Years of the Alternatives Approach: Refining, Reducing, and Replacing the Use of Laboratory Animals," in *State of the Animals: 2001*, 121–124.

to be as humane as possible.³⁰ Gesell experienced severe criticism from fellow scientists after speaking out at a medical meeting in 1952 against NSMR's opposition to measures to require humane treatment of research animals.³¹ One colleague called Gesell's statement "hysterical," and other colleagues wondered if his brain had been affected by a stroke he had suffered years earlier.³²

AWI opposed state and local laws that required shelters to turn over animals for research. Its preferred middle ground on the pound seizure issue was to permit animal shelters to voluntarily turn unclaimed animals over to researchers, but only for experiments where the animals would be properly anesthetized for the experiment and killed without ever regaining consciousness.³³ NSMR, in a 1956 statement, claimed that although AWI presented itself as more moderate than the anti-vivisection "cult," it nevertheless wanted to enact the anti-vivisection agenda.³⁴ From 1946 to 1964, NSMR presented an annual Research Dog Hero Award to a dog who had been used in cancer or heart disease experiments, to emphasize the benefits of animal research.³⁵

AWI and HSUS both wanted a federal law to regulate experimentation on animals, rather than fighting the battle on the state level.³⁶ In the early 1960s, HSUS deployed field investigators to gather information about animal dealers and help document the interstate nature of the animal trade, which was an important prerequisite for federal legislation.³⁷ Further publicity for the regulatory push in the early 1960s came from well-known activist Cleveland Amory, who founded the Fund for Animals in 1967. He published two articles in major national magazines in 1963 and appeared on the "Today" show arguing for the necessity of laws to protect research animals.³⁸

Due largely to humane activists' tenacious work in documenting the suffering of laboratory animals, an increasing number of members of Congress were sympathetic to the call for reasonable regulation. But the research industry was strong enough to kill the bills that were repeatedly introduced in Congress from 1960 to 1965 to regulate animal experimentation.³⁹ Ultimately, it was the research industry's lack of attention to how it acquired dogs and cats that would finally initiate Congressional action.

In 1965, the story of a stolen dog—a middle-aged female Dalmatian named Pepper—brought public attention to the research industry's relationship with private animal dealers. Pepper was owned by Julia Lakavage, who lived with her family on their farm in Slatington, Pennsylvania.⁴⁰ On June 22, 1965, Pepper disappeared. Lakavage advertised and searched for her without success. One week after Pepper's disappearance, on Tuesday, June 29th, the police in nearby Easton, Pennsylvania, stopped the driver of a

³⁰ McArdle, "What's Wrong with Pound Seizure?," 123–124.

³¹ Parascandola, "Physiology, Propaganda, and Pound Animals," 305–310.

³² *Ibid.*, 309.

³³ *Ibid.*, 300–301.

³⁴ "NSMR v. AWI," *Animal Welfare Institute Information Report* 5, no. 3 (May-June 1956): 3.

³⁵ Lederer, "Political Animals," 73.

³⁶ Oliver Evans, "How Can We Best Help Laboratory Animals Now," in *The Humane Movement, 1966: Selected Discussion Papers of the National Leadership Conference of the Humane Society of the United States, September 24–26* (Washington, D.C.: Humane Society of the United States, 1966), 37–45, http://animalstudiesrepository.org/cgi/viewcontent.cgi?article=1009&context=acwp_all; Bernard Unti, "Concentration Camps for Lost and Stolen Pets": Stan Wayman's LIFE Photo Essay and the Animal Welfare Act," paper 12 in *Animal Studies Repository: Animal Law and Legislation* (2007), http://animalstudiesrepository.org/cgi/viewcontent.cgi?article=1011&context=acwp_all; Unti, *Protecting All Animals*, 66.

³⁷ "Researchers and Animal Welfare Groups Battle Over Federal Control," *New York Times*, November 21, 1965; Unti, *Protecting All Animals*, 65–70; Unti, "Concentration Camps for Lost and Stolen Pets."

³⁸ "Cleveland Amory on Laboratory Animals," in *Animal Welfare Institute Information Report* 12, no. 3 (May-August 1963): 1. The Fund for Animals became affiliated with HSUS in 2005.

³⁹ Deborah Rudacille, *The Scalpel and the Butterfly: The Conflict Between Animal Research and Animal Protection* (Berkeley: University of California Press, 2000), 127.

⁴⁰ Coles Phinizy, "The Lost Pets That Stray to the Labs," *Sports Illustrated*, November 29, 1965, 36; Daniel Engber, "Where's Pepper?," *Slate Magazine*, June 1, 2009, accessed April 11, 2017, http://www.slate.com/articles/health_and_science/pepper/2009/06/wheres_pepper.html.

pickup truck that was overloaded with 18 dogs and two goats.⁴¹ The local animal shelter impounded the animals and held them overnight.⁴² The driver, William Miller, paid an \$84.00 fine for animal cruelty on Wednesday and was allowed to pick up the animals and resume his journey.⁴³ On Thursday, July 1st, Miller sold some of the dogs, including an adult female Dalmatian, to Montefiore Hospital in New York City.⁴⁴ The hospital's research laboratory used the unidentified Dalmatian in an experimental surgery the following day, 10 days after Pepper had disappeared.⁴⁵ The dog died during the surgery and the hospital incinerated her body.⁴⁶

Miller's arrest had been publicized in local news stories, including the fact that two of the dogs he had were Dalmatians.⁴⁷ Lakavage saw the stories and contacted the shelter where the dogs and goats had been taken, but not before Miller had picked up the animals and left.⁴⁸ Lakavage was told that Miller was on his way to sell the dogs to another animal dealer at a farm in High Falls, New York.⁴⁹ She drove to High Falls in the hope of finding Pepper, but was not allowed to visit the dealer's farm and was unable to get a search warrant.⁵⁰

Lakavage was not the only one following the news about Miller's arrest. The case had also attracted the attention of humane activists who had been investigating the activities of dog dealers for some time. When Lakavage was not allowed to look for Pepper at the High Falls farm, the activists contacted members of Congress for help.⁵¹ Representative Joseph Resnick asked the FBI if it could help Lakavage get a search warrant.⁵² Meanwhile, further questioning of Miller led him to admit that he had taken the Dalmatians to Montefiore Hospital. One of the humane activists called the hospital on July 3rd, and was told that an adult female Dalmatian had died in surgery the day before.⁵³ Although the hospital had already disposed of the dog's body, and Miller denied that the dog was Pepper, Lakavage identified Pepper as one of the dogs in Miller's possession from photographs taken by the animal shelter that had held the dogs overnight on June 29th.⁵⁴ The other Dalmatian in Miller's load was a puppy.⁵⁵

Pepper died on July 2, 1965, and on July 9th, Resnick introduced a bill to require licensing, inspection, and humane standards for dealers who acquired dogs and cats for research.⁵⁶ The goal of the experiment that took Pepper's life—to develop a pacemaker that would not require periodic invasive surgery to replace its battery⁵⁷—was one that most people probably would have supported. What made the case infuriating to so

⁴¹ "Researchers and Animal Welfare Groups Battle"; "U.S. Law Sought on Dog Stealing," *New York Times*, July 6, 1965; United Press International, "Man is Fined for Animal Cruelty," *Altoona Mirror*, July 1, 1965; Associated Press, "Dog Sale for Research Under Fire," *Indiana Evening Gazette*, July 7, 1965.

⁴² "U.S. Law Sought on Dog Stealing."

⁴³ United Press International, "Man is Fined for Animal Cruelty."

⁴⁴ "U.S. Law Sought on Dog Stealing."

⁴⁵ *Ibid.*

⁴⁶ *Ibid.*; Stevens, "Laboratory Animal Welfare," 74.

⁴⁷ Phinizy, "The Lost Pets That Stray to the Labs," 38.

⁴⁸ *Ibid.*

⁴⁹ Associated Press, "Woman Involves Many in Efforts to Find Her Dog," *Lebanon Daily News*, July 3, 1965.

⁵⁰ *Ibid.*

⁵¹ Stevens, "Laboratory Animal Welfare," 73–74.

⁵² Associated Press, "Woman Involves Many."

⁵³ "U.S. Law Sought on Dog Stealing"; Stevens, "Laboratory Animal Welfare," 74.

⁵⁴ Associated Press, "Dog Sale for Research Under Fire"; Stevens, "Laboratory Animal Welfare," 74.

⁵⁵ Engber, "Where's Pepper?."

⁵⁶ Stevens, "Laboratory Animal Welfare," 74. Eight other bills seeking to regulate laboratory use of animals were pending in Congress at the time. "Pet Theft Rings Called Thriving," *New York Times*, September 3, 1965.

⁵⁷ "U.S. Law Sought on Dog Stealing."

many ordinary people, and stimulated Resnick to introduce his bill, was not that the Montefiore Hospital scientists were doing the pacemaker experiments on dogs (who appear to have been anesthetized for the surgeries), but that scientists in general were so careless in how they obtained dogs. Resnick himself made it clear that he was not an anti-vivisectionist, and that his bill was directed at the theft of dogs and cats and the conditions they were kept in by dealers rather than the work by researchers.⁵⁸

A subcommittee of the House of Representatives held a hearing on the Resnick bill on September 2, 1965.⁵⁹ HSUS investigator, Frank McMahon, testified about dealers who bribed shelter employees to give them cats and dogs, sometimes before families had even had a chance to visit the shelter to look for their lost pets.⁶⁰ Dog owners testified about cases where municipal pounds had given their lost pets to dealers and then, when the owners came looking for their pets, claimed they never had them.⁶¹ An admitted dog thief testified to details about how dealers stole dogs and moved them across state lines.⁶² HSUS investigators had found evidence of dog theft rings in Delaware, Pennsylvania, New York, New Jersey, and Connecticut, and had concluded that large numbers of dogs and cats “lost” each year were really stolen by dealers.⁶³ The problem was particularly acute in Pennsylvania, which was centrally located to many of the major research centers of the east and Midwest.⁶⁴ One witness testified that boys in Pennsylvania were paid \$2.00 for each dog they could deliver to a dealer.⁶⁵

On November 28, 1965, while the Resnick bill was still pending, the New York Times published an article in support of a broader bill that was also pending in the House and Senate.⁶⁶ That bill, and other pending bills, proposed to regulate animal experimentation on several species, not just dogs and cats. This had been the goal of AWI, HSUS, and other humane organizations for a long time and now support was growing. The New York Times article pointed out that laboratory animals were often kept in cages that were not big enough to allow them to turn around, left to suffer for days after experiments, and subjected to multiple experiments.⁶⁷

Researchers tried to counter the momentum of the Resnick bill by supporting an alternate bill that focused on voluntary measures rather than mandatory standards. One medical doctor who wrote to the New York Times in support of the alternate bill decried the idea that a “nonscientist bureaucrat” could use “sentimental criteria” in making a decision on a laboratory’s licensing application.⁶⁸ The doctor raised the specter that requiring laboratories to be licensed would delay experiments and cause thousands of people to die, while making lawbreakers out of the best and brightest doctors who merely wanted to put their new ideas into action quickly.⁶⁹

For a while, it looked as though the research industry would succeed in killing the Resnick bill despite the momentum for reform created by the Pepper case, but then another scandal erupted that attracted even more public attention and outrage. While debate on the Resnick bill was underway, Stevens had sent

⁵⁸ “Pet Theft Rings Called Thriving”; Phinizy, “The Lost Pets That Stray to the Labs,” 41.

⁵⁹ Stevens, “Laboratory Animal Welfare,” 74.

⁶⁰ Bernard Unti, “Frank McMahon: The Investigator Who Took a Bite Out of Animal Lab Suppliers,” paper 22 in *Animal Studies Repository: Animal Abuse, Animal Welfare, and Animal Protection* (2013), http://animalstudiesrepository.org/cgi/viewcontent.cgi?article=1021&context=acwp_awap.

⁶¹ Phinizy, “The Lost Pets that Stray to the Labs,” 44.

⁶² Unti, *Protecting All Animals*, 71.

⁶³ Associated Press, “Dognapping Bill Kicks Up Fuss in Congress,” *Clearfield Progress*, January 10, 1966.

⁶⁴ *Ibid.*

⁶⁵ *Ibid.*

⁶⁶ “The Animal Laboratories,” *New York Times*, November 28, 1965.

⁶⁷ *Ibid.*

⁶⁸ Bent Boving, “Animals in Research,” Letters to the Editor, *New York Times*, December 10, 1965.

⁶⁹ *Ibid.*

Henry Luce, publisher of Life Magazine, evidence of shocking conditions that investigators had discovered at animal dealers' properties.⁷⁰ In February 1966, Life Magazine published a feature called "Concentration Camps for Dogs."⁷¹ The text of the story was about family pets stolen by dealers and maltreated before being sold for research, but it was the numerous photographs taken by Life photographer Stan Wayman that really caught the public's attention.

One striking photograph was of an emaciated purebred Pointer that was purchased by rescuers at an Oklahoma dog auction for \$3.00. Other photographs were from a raid on a dealer's property in Maryland. The Maryland raid was based on evidence gathered by HSUS investigator McMahon, who accompanied a Life Magazine crew to the scene. One photograph showed a dog that had frozen to death in a box. Another was of a beautiful collie who was lying on the ground with its eyes open, but was too weak to move. Two dogs were in a crate that was so small they could not even stand up. When they were lifted out of the crate, they were unable to walk.

The Life article also told the stories of a few dogs who had been stolen from their owners or seized from the pound, but were lucky enough to have returned home. One was a mixed breed who escorted the children in his family to school. He had been picked up by the dog warden on his way back home one day and was then sold to Harvard Medical School. The resourceful dog escaped and traveled the 20 miles back home on his own. He was still wearing a tag that said "H.M.S" with his laboratory number. Another dog had been stolen from her owner's back yard in Virginia and wound up with a dealer in Pennsylvania who sold her to the National Institutes of Health (NIH). NIH returned her to her owner after investigators traced her chain of custody.⁷²

Stevens made sure that every member of Congress got a copy of the Life article.⁷³ When a Congressional subcommittee held a hearing in March 1966 on one of the proposed bills to regulate how laboratories acquired animals, the crowd was too large to fit into the hearing room.⁷⁴ Fay Brisk, one of the humane activists who had been involved in the Pepper case, told the subcommittee about an auction she had attended where obviously sick cats and dogs were sold. Members of Congress reported that they were receiving more mail on pet theft and mishandling than on any other issue, and that most of it was in favor of the legislation.⁷⁵ After two days of testimony, the subcommittee approved the bill.⁷⁶

⁷⁰ Stevens, "Laboratory Animal Welfare," 74.

⁷¹ "Concentration Camps for Dogs," *Life Magazine* 60, no. 5 (February 4, 1966): 22–29.

⁷² Unti, *Protecting All Animals*, 69–70.

⁷³ Daniel Engber, "Pepper Goes to Washington," *Slate Magazine*, June 3, 2009, accessed April 11, 2017, http://www.slate.com/articles/health_and_science/pepper/2009/06/pepper_goes_to_washington.single.html.

⁷⁴ "Inquiry on Pets Draws Throngs," *New York Times* (Mar. 8, 1966).

⁷⁵ *Ibid.*

⁷⁶ "Safeguards Backed in Animal Research," *New York Times*, March 18, 1966.



Figure 25:
Laboratory cat. Cats are one of the species protected under the AWA.
Photograph by USDA. Public domain.

On April 28, 1966, the House of Representatives passed a bill to regulate dealers, but it had been watered down in the full Agriculture Committee.⁷⁷ A struggle ensued to pass a stronger bill in the Senate.⁷⁸ On June 22, 1966, one year to the day after Pepper disappeared, the Senate passed a somewhat stronger bill by an 85 to 0 vote.⁷⁹ A conference committee reported out a consensus version,⁸⁰ and on August 24, 1966, President Lyndon Johnson signed Public Law 89–544, known as the Laboratory Animal Welfare Act (LAWA), into law.⁸¹

The passage of the LAWA was a hard-fought victory for humane advocates. Their efforts over many years had been stymied until Pepper's death set in motion a series of events that rallied the public and persuaded Congress to act. As Stevens said in referring to Pepper's case, "it was the excesses of

the random-source dog dealers themselves that made it possible to pass the Laboratory Animal Welfare Act in 1966."⁸²

The LAWA's stated purpose included protecting owners of cats and dogs from the theft of their pets.⁸³ The bill went beyond the protection of pet dogs and cats, however, and authorized the Secretary of Agriculture to regulate the transportation, housing, and care of dogs, cats, monkeys, guinea pigs, hamsters, and rabbits to be used for experimentation.⁸⁴ It provided, among other things, that interstate dealers had to be licensed and research facilities could purchase dogs and cats only from licensed dealers or people who were exempt from licensing.⁸⁵ Both dealers and laboratories had to document the previous ownership and means of acquisition of dogs and cats.⁸⁶

In spite of these important provisions as to dealers, the law was weak in regulating laboratories. The LAWA stated that it did not give authority to the government to regulate the "handling, care, or treatment of animals during actual research or experimentation" by a laboratory, and researchers were allowed to define when

⁷⁷ "House of Representatives and Senate Commerce Committee Act on Animal Protective Legislation," *Animal Welfare Institute Information Report* 15, no. 2 (April-June 1966): 1.

⁷⁸ Stevens, "Laboratory Animal Welfare," 76; Unti, *Protecting All Animals*, 71–72.

⁷⁹ "Senate Votes a Bill for Pet Protection," *New York Times*, June 23, 1966; "House of Representatives and Senate Commerce Committee Act on Animal Protective Legislation," 1, 4.

⁸⁰ Stevens, "Laboratory Animal Welfare," 76.

⁸¹ "President Johnson Signs Bill for Humane Care of Research Animals into Law," *Animal Welfare Institute Information Report* 15, no. 3 (July-August 1966): 1–2; "LBJ Signs Poage-Magnuson Act; Suppliers of Dogs and Cats to Medical Research Are Hit Hard," *News of the Humane Society of the United States* 11, no. 5 (September 1966): 1, http://animalstudiesrepository.org/cgi/viewcontent.cgi?article=1004&context=v11_news.

⁸² Christine Stevens, "Historical Motivation for the Federal Animal Welfare Act," lecture presented at United States Department of Agriculture symposium on September 12, 1996, collected in *Animal Welfare Act 1966–1996: Historical Perspectives and Future Directions*, ed. Michael Kreger, D'Anna Jensen, and Tim Allen (Riverdale, MD: WARDS, 1998), 21, Internet Archive, <https://web.archive.org/web/20150221154122/http://www.nal.usda.gov/awic/pubs/96symp/awasymp.htm>.

⁸³ Public Law No. 89–544 (1966).

⁸⁴ *Ibid.*

⁸⁵ *Ibid.*, §§ 4, 7.

⁸⁶ *Ibid.*, § 10.

actual research or experimentation was taking place.⁸⁷ The law has been amended several times since 1966 and strengthened in many respects, including the addition of provisions that affect actual experimentation on animals.⁸⁸ It has been known since 1970 as the Animal Welfare Act (AWA).⁸⁹

Under the licensing system created after the passage of LAWA and its amendments, animal dealers who collected and sold dogs and cats from pounds, flea markets, etc. were designated as “Class B” (random source) dealers. The law did not prohibit pound seizure, but its requirement to document the previous ownership and means of acquisition of cats and dogs may have discouraged Class B dealers from taking cats and dogs from pounds before their hold periods had expired.

Inspired by its success with the AWA, the humane movement returned to the battle against pound seizure. The first major target of the renewed effort was New York.⁹⁰ In 1952, the state of New York had passed a pound seizure law known as the Metcalf-Hatch Act. All municipal shelters in the state and all private shelters that received state funds were required to turn over unclaimed animals on demand to any research institution.⁹¹ Since humane societies in New York could get out of the obligation to turn over animals for research by getting out of their municipal sheltering contracts, several of them did exactly that.

The ASPCA, which held the contract to manage animal control and sheltering for New York City from 1894 to 1994, had not worked to defeat the Metcalf-Hatch bill when it was before the legislature in 1952 and was not one of the organizations that gave up its sheltering contract to avoid complying with the law.⁹² Eventually though, in 1972, the ASPCA stopped turning over animals for research and joined the effort to repeal Metcalf-Hatch.⁹³ In 1977, a repeal bill passed one chamber in the state legislature by a wide margin, but did not make it out of committee in the other.⁹⁴ In 1979, the logjam was broken when a large coalition led by Henry Spira, an animal-rights activist, was able to get the repeal measure out of committee so that it could come up for debate.⁹⁵ Repeal finally passed the legislature and the governor signed it.⁹⁶

New York was the first of a wave of states that repealed their pound seizure laws.⁹⁷ Connecticut followed in 1980, not only repealing the law that compelled pound seizure but banning transfer of animals from shelters to research institutions.⁹⁸ This was important because merely repealing a pound-seizure law did not necessarily stop animals from going to research laboratories. Even without a law requiring pound seizure, individual shelters could choose to voluntarily sell animals to dealers and research institutions.⁹⁹

⁸⁷ *Ibid.*, § 13.

⁸⁸ Public Law No. 91–579 (1970); Public Law No. 94–279 (1976); Public Law No. 99–198 (1985); Public Law No. 101–624 (1990); Public Law No. 107–171 (2002); Public Law No. 110–22 (2007); Public Law No. 110–246 (2008); Public Law No. 112–261 (2013).

⁸⁹ Public Law No. 91–579 (1970).

⁹⁰ Rowan, *Of Mice, Models, and Men*, 151–152.

⁹¹ *Ibid.*, 151.

⁹² Marion Lane and Stephen Zawistowski, *Heritage of Care: The American Society for the Prevention of Cruelty to Animals* (Westport, CT: Praeger, 2008), 37–38; Unti, *Protecting All Animals*, 104.

⁹³ Lane and Zawistowski, *Heritage of Care*, 38; Marjorie Anchel, “Appendix B: Editor’s Notes,” in *Overpopulation of Cats and Dogs*, 256.

⁹⁴ Rowan, *Of Mice, Models, and Men*, 152.

⁹⁵ Peter Singer, *Ethics into Action: Henry Spira and the Animal Rights Movement* (Lanham, MD: Rowman & Littlefield, 1998), 78–83.

⁹⁶ *Ibid.*, 83.

⁹⁷ As of October 2016, according to HSUS, eighteen states have laws banning pound seizure, only Oklahoma still has a law mandating pound seizure, and the rest of the states either allow individual jurisdictions to adopt pound seizure rules or do not address the issue. “State Pound Seizure Laws,” *Humane Society of the United States*, accessed April 12, 2017, http://www.humanesociety.org/assets/pdfs/animals_laboratories/pets_experiments/map_pound_seizure_laws.pdf.

⁹⁸ Rowan, *Of Mice, Models, and Men*, 152.

⁹⁹ And even with a ban on pound seizure within a state, laboratories can import pound animals from other states unless importation is also banned. McArdle, “What’s Wrong with Pound Seizure?,” 119.

In 1990, Congress enacted an amendment to the AWA known as the Pet Theft Act.¹⁰⁰ The Pet Theft Act requires that any public animal shelter, private entity with a contract to run a public shelter, or licensed research facility must hold dogs and cats not less than five days before selling them to a dealer.¹⁰¹ The hold requirement does not make an exception for owner-surrendered animals. The Act states that the purpose of the hold period is “to enable such dog or cat to be recovered by its original owner or adopted by other individuals.” The Pet Theft Act did not ban dealers from acquiring animals from public shelters, but it did add another hoop for Class B dealers to jump through.¹⁰²

The AWA, the repeal of many state pound seizure laws, and the Pet Theft Act placed some limitations on Class B dealers and created some barriers for their business, but enforcement was problematic. Class B dealers licensed under the AWA could, if they wished, acquire animals in dishonest or deceptive ways and then falsify or launder paperwork to make it appear legitimate.¹⁰³ Nevertheless, the number of licensed Class B dealers declined from over 100 in the early 1990s to only nine in 2010.¹⁰⁴ Developments since 2010 have slashed that number even further.¹⁰⁵

Legal restrictions were no doubt part of the cause for the plunge in the number of Class B dealers, but other factors were at work as well. One such factor was that Class B dealers were confronted with a declining market for their goods. Researchers increasingly purchased cats and dogs for laboratory use from Class A dealers, who sell so-called “purpose-bred” animals (animals bred specifically for a particular purpose, such as research). Using purpose-bred animals whose genetic background and growth conditions are known helps remove random variables from experiments, and many scientists therefore prefer to use them in spite of their higher cost.

The use of purpose-bred animals, while it helps reduce the likelihood that pets and shelter animals will wind up in laboratories, still causes concern to humane activists and the public. In fact, public approval of animal research has declined steadily from its high point after World War II. Approval of animal research was around 85% in polls held in the late 1940s.¹⁰⁶ Surveys by the National Science Board in the years from 1985 to 1990 found that approval for using animals like dogs and chimpanzees in medical research fell from 63% to 50%.¹⁰⁷ The Gallup organization’s “Morals and Beliefs” survey showed a decline of nine percentage points in public opinion about the morality of animal research from 2001 to 2015.¹⁰⁸ A poll conducted by the Pew Research Center in 2014 which asked whether people favored or opposed the use

¹⁰⁰ The Pet Theft Act, Public Law # 101-624, was enacted on Nov. 28, 1990.

¹⁰¹ 7 U.S.C. § 2158(a).

¹⁰² Nancy Wilks, “The Pet Theft Act: Congressional Intent Plowed Under by the United States Department of Agriculture,” *Animal Law Review* 1 (1995): 105.

¹⁰³ Unti, *Protecting All Animals*, 105.

¹⁰⁴ “Animal Welfare: USDA’s Oversight of Dealers of Random Source Dogs and Cats Would Benefit from Additional Management Information and Analysis,” GAO-10-945, Government Accounting Office (September 2010), 7.

¹⁰⁵ Wayne Pacelle, “NIH Terminates Funding for Research Using Randomly Sourced Dogs,” Humane Society of the United States, accessed April 12, 2017, <http://blog.humanesociety.org/wayne/2014/10/nih-class-b-dealers.html>; Wayne Pacelle, “Time Running Out For Class B Dealers,” Humane Society of the United States, accessed April 12, 2017, <http://blog.humanesociety.org/wayne/2015/05/class-b-dog-dealer-cancels-usda-license.html>; “Notice Regarding NIH Plan to Transition From Use of USDA Class B Dogs to Other Legal Sources,” National Institutes of Health, accessed April 12, 2017, <https://grants.nih.gov/grants/guide/notice-files/NOT-OD-14-034.html>; “Notice Regarding NIH Plan to Transition From Use of USDA Class B Cats to Other Legal Sources,” National Institutes of Health, accessed April 12, 2017, <https://grants.nih.gov/grants/guide/notice-files/NOT-OD-12-049.html>.

¹⁰⁶ Justin Goodman, “Public Opinion on Animal Testing,” *AV Magazine* 120, no. 1 (2012): 20–21; Andrew Rowan, Franklin Loew, and Joan Weer, *The Animal Research Controversy: Protest, Process, and Public Policy* (North Grafton, MA: Tufts University, 1995), 11 (citing National Society for Medical Research, “Public Attitudes to Animal Research” (1949)).

¹⁰⁷ “Science and Engineering Indicators,” *National Science Board* (1991), 181–182, 455, accessed April 12, 2017, <http://files.eric.ed.gov/fulltext/ED344780.pdf>.

¹⁰⁸ Frank Newport, “Americans Continue to Shift Left on Key Moral Issues,” *Gallup*, May 26, 2015, last accessed July 20, 2017, <http://www.gallup.com/poll/183413/americans-continue-shift-left-key-moral-issues.aspx>.

of “animals” in scientific research, with no reference to particular species, found only 47% of the public in favor of it.¹⁰⁹

Researchers themselves have questioned the use of animals in experiments, both because of their own ethical concerns and because results from animal experiments cannot always be applied to humans.¹¹⁰ The desire of both the public and researchers to minimize the use of animals in laboratories has led to a host of new research techniques that do not use animals.¹¹¹ HSUS estimates, however, that over 25 million vertebrate animals are still used annually in research and training in the United States, the great majority of which are species like rats and mice that are not covered by the AWA.¹¹² Although much progress has been made and there is hope for a future end of animal experimentation, research on animals remains an important issue for humane advocates.

The battle against pound seizure was important for shelter animals, but it had a broader importance as well. The research industry’s aggressive use of pound seizure after World War II mobilized the humane movement, and the failure of researchers to take steps to prevent pet theft in their supply pipeline gave the movement an effective weapon against animal research. The resulting passage of statutes and regulations for the protection of animals in research was an accomplishment that would have seemed impossible before the 1950s. The pound-seizure controversy is generally credited with waking the humane movement up from the stasis it had fallen into between 1920 and 1950, and making it into a vital social movement once again.¹¹³

¹⁰⁹ Cary Funk and Lee Rainie, “Opinion About the Use of Animals in Research,” chap. 7 in *Americans, Politics and Science Issues*, July 1, 2015, *Pew Research Center*, <http://www.pewinternet.org/2015/07/01/chapter-7-opinion-about-the-use-of-animals-in-research/>.

¹¹⁰ Gill Langley, “Humane Research,” in *Global Guide to Animal Protection*, 260–261.

¹¹¹ Stevens, Goldberg, and Rowan, “The First Forty Years of the Alternatives Approach,” 126–134; Rudacille, *The Scalpel and the Butterfly*, 158–171.

¹¹² “Questions and Answers About Biomedical Research,” *Humane Society of the United States*, accessed April 13, 2017, http://www.humanesociety.org/issues/biomedical_research/qa/questions_answers.html.

¹¹³ Bernard Unti and Andrew Rowan, “A Social History of Postwar Animal Protection,” in *State of the Animals: 2001*, 21–22; Unti, *Protecting All Animals*, 2–3.

Part III: Shelters and Pet Population

Chapter 8: The Pet Overpopulation Crisis

In the early 1970s, scientists published alarming reports in academic journals on the deleterious effects that free roaming cats and dogs were having on human health and quality of life in the United States.¹ They warned that the problems would get worse if nothing was done. The term “pet overpopulation” was heard with increasing frequency, and the popular media weighed in with articles about the worsening crisis.²



Figure 26:
Highbridge Park in Manhattan was home to a substantial pack of feral dogs for decades, including “Ricky,” visible in this 2011 photograph. Photograph by Kristine Paulus, licensed under CC BY 2.0.

City residents took these messages to heart because they were experiencing problems with free roaming pets in their own neighborhoods.³ A 1974 national survey of mayors reported in the July 29, 1974 issue of *Nation's Cities Weekly* showed that animal control issues were the top concern of city residents. Traffic ranked second to animal issues on the list of complaints, and crime was way back in 8th place.⁴ Animal shelters in the United States were reporting increased intake of dogs.⁵ A study done in Baltimore from 1978 to 1981 documented that over 50% of surveyed households reported problems with free roaming cats and over 80% reported problems with free roaming dogs.⁶ A 1979 book on the problem stated that packs of roaming dogs were a common sight and unsupervised dogs were a nationwide concern.⁷

The situation could seem overwhelming to people concerned about the welfare of animals. A member of an anti-cruelty group in Albuquerque, New Mexico in the 1960s described the city as having free roaming dogs and cats everywhere.⁸ Puppies were offered for free on the street, and dead cats and dogs who had been killed by cars were often seen on the side of the road.

We have some data on shelter intake in individual cities and counties from the 1960s and 1970s. That data indicates that the pet overpopulation crisis was real, at least from the perspective of animal shelters. The

¹ Carl Djerassi, Andrew Israel, and Wolfgang Jochle, “Planned Parenthood for Pets?,” *Bulletin of the Atomic Scientists* 29, no. 1 (January 1973): 10–19, doi:10.1080/00963402.1973.11455434; Bruce Max Feldmann, “The Problem of Urban Dogs,” *Science* 185, no. 4155 (September 13, 1974): 903, doi:10.1126/science.185.4155.903; Andrew Rowan and Jeff Williams, “The Success of Companion Animal Management Programs: A Review,” *Anthrozoös* 1, no. 2 (1987): 110, doi:10.2752/089279388787058623.

² Elisabeth Clancy and Andrew Rowan, “Companion Animal Demographics in the United States: A Historical Perspective,” in *The State of the Animals II: 2003*, ed. Deborah Salem and Andrew Rowan (Washington, DC: Humane Society Press, 2003), 14; Rowan and Williams, “Success of Companion Animal Management Programs,” 110 (citing articles in *Time*, *Esquire*, and *Mad* magazines); Karl Kessler, “Keynote Address,” in *Proceedings of the National Conference on Dog and Cat Control, Feb. 3–5, 1976* (Denver: American Humane Association, 1976), 17 (citing articles in the *Christian Science Monitor*, *Washington Post*, *U.S. News and World Report*, *Harper's Bazaar*, and *McCall's*, among others).

³ Robert Allen and William Westbrook, “The Pet Paradox,” chap. 1 in *The Handbook of Animal Welfare: Biomedical, Psychological, and Ecological Aspects of Pet Problems and Control*, ed. Robert Allen and William Westbrook (New York: Garland STPM Press, 1979), 4.

⁴ Allen and Westbrook, “Pet Paradox,” 3–4.

⁵ Alan Beck, “The Public Health Implications of Urban Dogs,” *American Journal of Public Health* 65, no. 12 (December 1975): 1315, doi:10.2105/AJPH.65.12.1315.

⁶ James Childs, abstract for “The Ecology and Public Health Impact of Urban Cats in Baltimore, Maryland,” (PhD diss., Johns Hopkins University, 1982), ii.

⁷ Allen and Westbrook, “The Pet Paradox,” 4.

⁸ Tami Harbolt, *Bridging the Bond: The Cultural Construction of the Shelter Pet* (West Lafayette, IN: Purdue University Press, 2003), 50.

state of California collects data on shelter intake for its rabies control program. In the 19 years from 1956 through 1974, the number of dogs impounded annually by public shelters that reported to the state rose from 126,472 to 808,038.⁹ A survey done in New York State showed that intake for a group of 19 shelters increased from 272,418 in 1967 to 307,956 in 1971.¹⁰ The San Francisco SPCA reportedly had intake of around 65,000 a year in the mid-1960s.¹¹ The City of Los Angeles Department of Animal Regulation took in 144,530 cats and dogs in fiscal year 1971 to 1972, up from 133,040 in fiscal year 1969 to 1970 and 118,082 in fiscal year 1968 to 1969.¹² The ASPCA's intake in New York City peaked in the 1920s and 1930s due to an extremely high cat intake in the early decades of the 20th century, but it still took in over 136,000 cats and dogs in 1974.¹³ If these individual reports were representative of the nation as a whole, then animal shelter intake nationally in the 1960s and 1970s was far higher than it is today.

Much of the publicity about the pet overpopulation crisis centered on free roaming dogs. The apparent increase in the number of free roaming dogs may have been due in part to the rapid suburbanization that occurred after World War II.¹⁴ As returning veterans married, moved to the suburbs, and started families, the demand for pets increased. Suburban homes with yards were particularly conducive to keeping dogs, and the picture of happy family life in those days often included a dog. Dog food sales increased at an average rate of 13% per year from 1965 to 1975.¹⁵ Owned pets may have produced more puppies more often than in years past due to better veterinary care and nutrition.¹⁶ And, as discussed in the next chapter, sterilization of pets was uncommon before the 1970s.

Purebred dogs had been status symbols since the 1800s, but before World War II they were primarily bred as a hobby, often by wealthy people who showed dogs. The pet puppies sold by these hobby breeders had usually been well fed, given veterinary care, and socialized. During the era of suburbanization, purebreds spiked in popularity. The American Kennel Club registered 1.1 million dogs in 1972.¹⁷ Commercial breeding operations that grew in scale after World War II catered to the demand for purebred dogs.¹⁸ Many of these operations marketed puppies through pet stores.

Free roaming cats did not receive nearly as much media attention as free roaming dogs in the 1970s.¹⁹ One 1975 study in California concluded, however, that the overpopulation problem with cats was even worse than with dogs because cats reproduced at a more rapid rate.²⁰ The free roaming cat population has always been hard to track, partly because of the large reservoir of feral cats and partly because shelter statistics for cats are of limited value since animal control operations have historically had wide variations in their approach to impounding cats. When pounds, and later animal shelters, originated in the 1800s their

⁹ Theodore Sorich, "Reduced Cost for Surgical-Neutering Programs," in *Proceedings of the National Conference on Dog and Cat Control*, 217.

¹⁰ Argus Archives, *Unwanted Pets and the Animal Shelter: The Pet Population Problem in New York State*, Report Series # 4 (n.p.: Argus Archives, 1973), 15.

¹¹ Richard Avanzino, interview by author, July 23, 2014.

¹² Andrew Rowan, "Animal Control, Animal Welfare, and Proposals for an Effective Program," in *Proceedings of the First New England Conference on Animals and Society* (Boston: Center for Animals, 1984), 41, table 5; MVP Special Report, "Short Fuse on the Pet Population Bomb," *Modern Veterinary Practice* 52, no. 3 (March 1971).

¹³ Stephen Zawistowski et al., "Population Dynamics, Overpopulation, and the Welfare of Companion Animals: New Insights on Old and New Data," *Journal of Applied Animal Welfare Science* 1, no. 3 (1998): 202, table 4, doi:10.1207/s15327604jaws0103_1.

¹⁴ *Ibid.*, 194. An increase in outdoor dog populations was noted in Britain starting in the early 1950s, coinciding with an increase in the construction of "council" housing. Jenny Remfry, *Ruth Plant: A Pioneer in Animal Welfare* (Barnet, UK: Falkland Press, 2001), 16.

¹⁵ Beck, "Public Health Implications of Urban Dogs," 1315.

¹⁶ Zawistowski et al., "Population Dynamics," 194.

¹⁷ Beck, "Public Health Implications of Urban Dogs," 1315.

¹⁸ Katherine Grier, *Pets in America: A History* (Chapel Hill: University of North Carolina, 2006), 269–70; Martha Armstrong, Susan Tomasello, and Christyna Hunter, "From Pets to Companion Animals," in *The State of the Animals: 2001*, ed. Deborah Salem and Andrew Rowan (Washington, DC: Humane Society Press, 2001), 75.

¹⁹ Rowan and Williams, "Success of Companion Animal Management Programs," 110.

²⁰ *Ibid.*

primary purpose was dog control, and throughout the 1900s many shelters treated cats as an afterthought, if they impounded them at all. In Baltimore in 1970, for example, the animal shelter accepted owner-surrendered cats but animal control did not routinely pick up free roaming cats.²¹

Although the media concentrated on problems presented by free roaming dogs in the 1970s, public health officials were concerned about health threats posed by both cats and dogs. Rabies, of course, was at the top of the list of zoonotic diseases. In the 1970s a bite from a mammal who was not available for quarantine meant a very painful series of preventive rabies vaccinations (today the vaccinations are much less painful).

Another major zoonotic problem was parasites. A 1974 article by a public health expert noted that 40 of the 65 zoonoses that could be transmitted from cats and dogs to humans were known to occur in the United States.²² Worms in dogs were common in those days, and could cause serious health consequences in people.²³ Children were especially prone to acquiring infections from dog feces because they played outdoors. In addition to the esthetic problem of large amounts of feces and the difficulties caused to pedestrians, dog feces led to large numbers of flies. Dog feces were second only to trash cans in the production of flies in residential areas, which in turn led to a significant possibility of salmonella transmission.²⁴ Runoff of animal feces generally went into the storm-sewer system instead of the sanitary system. In Baltimore, dog feces wound up in the city's harbor.²⁵ "Curb laws" and "scoop laws" requiring people to clean up their dogs' feces began to be enacted in the 1970s in reaction to these problems.²⁶ Another sanitary problem with free-roaming dogs was that they overturned trash cans, which encouraged the growth of rat populations.²⁷

Cat parasites could be a more difficult problem for homeowners than dog parasites, since it was not easy to fence cats out of yards. A 1980 study in Baltimore showed that more than 40% of homes with fenced yards and no resident pets nevertheless had visible cat feces in the yards.²⁸ Many of the cats admitted to the Baltimore city shelter were shedding various types of parasitic eggs.²⁹ Cat feces can contain eggs of the parasite *Toxoplasma gondii*, the cause of toxoplasmosis. Fifteen percent of a sample of cats of mixed origin in Baltimore in the late 1970s and early 1980s had antibodies to the parasite, although only one cat was found to be actively shedding *Toxoplasma gondii* eggs.³⁰ Even when feces were not visible, soil could be contaminated. In the 1980 Baltimore study, 9% of soil samples from yards were positive for hookworm and 24% were positive for some type of parasite.³¹

²¹ Alan Beck, *The Ecology of Stray Dogs: A Study of Free-Ranging Urban Animals* (1973; repr., West Lafayette, IN: Purdue University Press/NotaBell Books, 2002), 44.

²² Alan Beck, "Ecology of Unwanted and Uncontrolled Pets," in *Proceedings of the National Conference on the Ecology of the Surplus Dog and Cat Problem, May 21–23, 1974* (Denver: American Humane Association, 1974), 35–36.

²³ Beck, *Ecology of Stray Dogs*, 53–54, 59–65.

²⁴ *Ibid.*, 56.

²⁵ *Ibid.*, 57–58.

²⁶ *Ibid.*, 58–59; see generally, Michael Brandow, *New York's Poop Scoop Law: Dogs, the Dirt, and Due Process* (West Lafayette, IN: Purdue University Press, 2008).

²⁷ Allen and Westbrook, "Pet Paradox," 4.

²⁸ Childs, "Ecology and Public Health Impact of Urban Cats," 197.

²⁹ *Ibid.*, 181.

³⁰ *Ibid.*, 148, 155, 165.

³¹ *Ibid.*, 193.



Figure 27:
Carl Djerassi, 2004. Photograph from Science History Institute,
licensed under CC BY-SA 3.0.

One of the most widely read of the academic articles about the pet overpopulation crisis appeared in January 1973 in the *Bulletin of Atomic Scientists*.³² Carl Djerassi, a professor of chemistry at Stanford University, was the lead author. The authors estimated that over 12% of the dog and cat population (excluding neonates killed by their owners) was destroyed each year in animal shelters.³³

Another influential paper about the pet-overpopulation problem appeared in the December 1973 issue of the journal *Health Services Reports*.³⁴ The authors of the article, Bruce Max Feldmann and Tony Carding, stated that in many communities free-roaming cats and dogs had created severe problems.³⁵ They listed bites, diseases transmitted to humans, property damage, harm to wildlife, accidents, pollution, cost of animal control, and nuisances as issues created by free roaming dogs and cats. To solve the problem, they advocated discouraging pet ownership, encouraging sterilization of female cats and dogs, encouraging people who no longer wanted their pets to surrender them to animal shelters, and prohibiting abandonment of pets.³⁶ Feldmann published a shorter version of these concerns as the lead editorial in the

September 1974 edition of the prestigious journal *Science*.³⁷ He warned that the perception of the American people that the dog was a harmless companion was changing.

Feldmann was a veterinarian who directed the University of California Pet Clinic at Berkeley. Carding was the director of the World Federation for the Protection of Animals. Feldmann and Carding appear to have believed that the pet overpopulation crisis was so dire that they—as animal welfare professionals—had to recommend that public officials discourage pet ownership and have animal-control organizations take in unwanted animals. One concern was that if the situation continued people would begin to see cats and dogs more as dangerous nuisances and less as beloved pets, and turn against them. Alan Beck, an expert on free roaming dogs, observed that dogs, once regarded as man’s best friend, were increasingly attracting the attention of physicians and policymakers due to the problems they were causing.³⁸ A veterinarian who spoke at a national conference in 1976 remarked that people were becoming hostile to pets due to the pet overpopulation situation.³⁹

Much of what we know today about free roaming dogs and cats in the 1970s and 1980s comes from ecological studies, including studies done in Baltimore, Sacramento, and Brooklyn. Baltimore was the venue for several of the studies because it is the home of Johns Hopkins University, with its school of public

³² Djerassi, Israel, and Jochle, “Planned Parenthood for Pets?,” 10.

³³ *Ibid.*, 12.

³⁴ Bruce Max Feldmann and Tony Carding, “Free-Roaming Urban Pets,” *Health Services Reports* 88, no. 10 (December 1973): 956–962, doi:10.2307/4594959.

³⁵ *Ibid.*, 957.

³⁶ *Ibid.*, 959–961.

³⁷ Feldmann, “Problem of Urban Dogs,” 903.

³⁸ Beck, “Public Health Implications of Urban Dogs,” 1317.

³⁹ Loyd Faulkner, “Alternatives to Ovariohysterectomy,” in *Proceedings of the National Conference on Dog and Cat Control*, 125.

health. One of the first of the studies was done by Alan Beck in Baltimore in 1970 and 1971, examining the urban dog.⁴⁰ Robert Allen and William Westbrook compared the ecology of free roaming dogs in different neighborhoods in Sacramento in 1974 and 1975.⁴¹ James Childs did studies on urban cats in Baltimore in the late 1970s and early 1980s.⁴² Carol Haspel and Robert Calhoon did studies in the early 1980s on free roaming cat populations in two neighborhoods in Brooklyn.⁴³

The ecological studies on free roaming cats and dogs, in addition to providing information about public health issues in the 1970s and 1980s, give us a picture of what life was like for outdoor dogs and cats in those years. Some homeless dogs and cats lived their entire lives in the streets, and they could be studied in this habitat in much the way that non-domesticated animals are studied in the wild. Many owned animals spent considerable time roaming freely as well. The work of the urban ecologists in the 1970s and 1980s showed that homeless cats and dogs could not only survive but thrive in city environments.

There were several striking findings in these studies, but one of the most surprising was that free-roaming cats and dogs found plenty of food. Dogs often obtained food by turning over trash cans and digging out their contents.⁴⁴ The photographs from Beck's study show mostly metal garbage cans with non-locking lids, which were easy for dogs to turn over.⁴⁵ Beck observed dogs picking up plastic garbage bags and carrying them to a hiding place where they could go through the contents at their leisure.⁴⁶ Dogs followed garbage trucks and scavenged what was spilled or left behind. Some residents also fed them. Two dogs that Beck studied never spent more than 11% of any activity period in directly foraging for food.⁴⁷ If a dog was noticeably thin, it was often an indication of illness rather than lack of food.⁴⁸

The 1975 Sacramento study looked at free roaming dogs in three types of neighborhoods: inner city, suburban, and rural.⁴⁹ The area with the highest number of free roaming dogs was the suburbs, but the difference in numbers among inner city, suburban, and rural areas was not large.⁵⁰ The study found that 71% of free roaming dogs were wearing collars, indicating that they were owned. Significantly more dogs were observed free roaming on the weekend than on weekdays. The dogs generally appeared to be healthy. Of 2,588 direct human-dog interactions observed, 78% were friendly, including social interactions and people feeding dogs.⁵¹ About 4% of the total direct interactions involved aggression or threat initiated by the dog. The researchers noted that the results of their study were consistent with the results of other studies of free roaming dogs, indicating a predictability in the behaviors of free roaming dogs across a variety of environments.⁵²

⁴⁰ Beck, *Ecology of Stray Dogs*.

⁴¹ Robert Allen and William Westbrook, "Animal Field Research," chap. 12 in *The Handbook of Animal Welfare*, 150.

⁴² Childs, "Ecology and Public Health Impact of Urban Cats," 11, 20–21, 25.

⁴³ Robert Calhoon and Carol Haspel, "Urban Cat Populations Compared by Season, Subhabitat, and Supplemental Feeding," *Journal of Animal Ecology* 58, no. 1 (February 1989): 321–322, doi:10.2307/5003; Carol Haspel and Robert Calhoon, "Activity Patterns of Free-Ranging Cats in Brooklyn, New York," *Journal of Mammalogy* 74, no. 1 (February 1993): 1–2, doi:10.2307/1381900.

⁴⁴ Beck, *Ecology of Stray Dogs*, 23.

⁴⁵ *Ibid.*, 23, 52.

⁴⁶ *Ibid.*, 23.

⁴⁷ *Ibid.*, 26.

⁴⁸ *Ibid.*, 28.

⁴⁹ Allen and Westbrook, "Animal Field Research," 150.

⁵⁰ *Ibid.*, 152.

⁵¹ *Ibid.*, 156, table 12-2.

⁵² *Ibid.*, 161.

In examining cats killed by cars in Baltimore, Childs found that their weights were similar to the weights of indoor cats.⁵³ Few of the cats he saw in alleys appeared to be underfed. Calhoun and Haspel found that food was plentiful in Brooklyn for cats as well, and that the number of cats was not limited by the available food.⁵⁴ They found that food in trash was sufficient to feed all the cats present in both of the neighborhoods they studied and that people also fed the cats.

Calhoun and Haspel found that shelter was a limiting factor for cat populations, and that the number of cats was directly proportional to the accessible space in abandoned buildings.⁵⁵ English biologist Roger Tabor similarly found that the amount of shelter was related to feral cat density in his studies of feral cats in London in the 1970s.⁵⁶ Calhoun and Haspel theorized that sheltering in abandoned buildings allowed cats to hide from people and come out at night to forage. Beck noted that dogs, by contrast, could shelter in relatively public areas in Baltimore because they were accepted by their human neighbors.⁵⁷ He used the term “cultural camouflage” for the phenomenon of homeless dogs who were tolerated because they were indistinguishable from free roaming owned pets.⁵⁸

Conventional wisdom portrays most people as despising homeless cats, but Childs found that many people cared about them. He noted that 16% of the surveyed households in his study fed outdoor cats.⁵⁹ Mother cats and their litters were sometimes given food, shelter, and support by nearby residents.⁶⁰ People also had sympathy for free roaming dogs. In spite of the problems caused by dogs, people would sometimes shoo dogs away to safety when they spotted an animal control truck.⁶¹



Figure 28:
Baltimore's Charles Village neighborhood was one of the areas Childs surveyed. Public domain.

Another enduring belief about free roaming cats and dogs is that they live only a few weeks or months because they are killed quickly by disease, injury, or exposure. Beck's Baltimore study indicated that the life of a free roaming dog was hazardous, but perhaps not as bad as the popular perception. The number of dead dogs picked up by Baltimore animal control in one year from July 1970 through June 1971 represented about one in five of the estimated number of free roaming dogs.⁶² This understates the number killed to some extent because not all of the dogs who died were picked up by animal control. Automobiles

⁵³ Childs, “Ecology and Public Health Impact of Urban Cats,” 114.

⁵⁴ Calhoun and Haspel, “Urban Cat Populations Compared,” 327.

⁵⁵ *Ibid.*

⁵⁶ Remfry, *Ruth Plant*, 50–51.

⁵⁷ Beck, *Ecology of Stray Dogs*, 32.

⁵⁸ Alan Beck and Aaron Katcher, *Between Pets and People: The Importance of Animal Companionship*, rev. ed. (West Lafayette, IN: Purdue University Press, 1996), 231.

⁵⁹ Childs, “Ecology and Public Health Impact of Urban Cats,” 92.

⁶⁰ *Ibid.* 141–142.

⁶¹ Beck, *Ecology of Stray Dogs*, 40.

⁶² *Ibid.*, 8, 35.

were the most likely cause of death from injury, and death from exposure to the elements appeared to be rare.⁶³

Shelters could be as much of a hazard to free roaming animals as were disease and injury. Roughly 15% of the entire estimated dog population in Baltimore, both owned and free-roaming, was killed or sent to research laboratories by the city shelter during the year from July 1970 through June 1971.⁶⁴ Shelter killing, disease, and injury were apparently not enough to keep the population of free roaming and owner-surrendered dogs in check in Baltimore, as the number of dogs taken in by the shelter had reportedly been continuously increasing for the previous 30 years.⁶⁵

The odds of survival for owner-surrendered cats who were impounded in Baltimore were abysmal. The Baltimore shelter received 4,178 owner-surrendered cats and kittens in 1978 and 4,951 in 1979.⁶⁶ Only 13 of them were adopted.⁶⁷ All the rest were transferred to laboratories for experimentation or killed by the shelter.

Mortality of puppies and kittens born to free roaming mothers was much higher than mortality of free roaming adult animals. The observed survival rate for puppies born to free-roaming mothers in Beck's study in their first eight months was a little more than 25%.⁶⁸ Only 33% of kittens in Childs' survey survived their first four months, but even this low survival rate was likely overstated because it did not include kittens who died in the first four to six weeks after birth, before the litters were located and observed.⁶⁹ Kittens who survived their first four months had an excellent chance to survive their first year.⁷⁰ Several kittens who were observed to be sick before dying had symptoms consistent with an upper respiratory virus complicated by subsequent bacterial infection.⁷¹ Other kittens found dead showed no sign of trauma or disease, and may have been killed by rat poison.⁷²

The number of free roaming dogs per square mile in Beck's study was estimated at from 627 to 835 in one neighborhood with predominantly single-family housing, and 1270 to 1690 in a neighborhood with predominantly multi-unit housing.⁷³ Cat density was estimated in Childs' study as ranging from 725 to 1,812 per square mile.⁷⁴ Baltimore was undergoing an economic downturn in the 1970s, so it may have had more free-roaming animals than an average city, but these numbers are strikingly high.

The ready availability of unowned cats and dogs in neighborhoods in the 1970s may have reduced the likelihood that a person would go to the effort of adopting a pet from a shelter. A person in the 1970s who wanted a pet could often acquire one from the street or from a friend or neighbor whose pet had a litter. In a study done in the Las Vegas area in 1982, 84.3% of owned dogs and 88.3% of owned cats had been acquired at less than one year of age.⁷⁵ Of those, 56% of dogs and 46% of cats were acquired from other

⁶³ Ibid., 35.

⁶⁴ Ibid., 10–11, 35.

⁶⁵ Ibid., 41.

⁶⁶ Childs, "The Ecology and Public Health Impact of Urban Cats," 138.

⁶⁷ Ibid., 141.

⁶⁸ Beck, *Ecology of Stray Dogs*, 44.

⁶⁹ Childs, "Ecology and Public Health Impact of Urban Cats," 142, 144, 213.

⁷⁰ Ibid., 144.

⁷¹ Ibid., 145.

⁷² Ibid., 213.

⁷³ Beck, *Ecology of Stray Dogs*, 8. For the city as a whole, Beck estimated from 450 to 750 stray dogs per square mile.

⁷⁴ Childs, abstract for "Ecology and Public Health Impact of Urban Cats," iv.

⁷⁵ R. Nassar, J. E. Mosier, and L. W. Williams, "Study of the Feline and Canine Populations in the Greater Las Vegas Area," *American Journal of Veterinary Research* 45, no. 2 (March 1984): 284, table 3.

pet owners, and 8% of dogs and 19% of cats were acquired as strays. Breeders or pet stores were the source of 20% of dogs and 10% of cats, and only 13% of dogs and 10% of cats had been acquired from a shelter.

One could argue that if it were not for the dangers presented by automobiles and animal control the lives of adult dogs and cats in the street in the 1970s and 1980s, with freedom to come and go as they wanted, to choose other animals to socialize or breed with, and with adequate food and water, would have been better than the lives of some “pampered” pets who were confined in a yard or house and had to wait all day for owners to return home from work. The lives of free roaming cats and dogs as documented by ecological studies did not correspond to the conventional wisdom that a dog or cat out on the street was almost certain to suffer horribly from hunger, thirst, and abuse and die quickly. Animals “rescued” from the street and taken to a city or county shelter in the 1970s and 1980s faced a very high probability of being killed or sold to laboratories as research subjects, so most of those animals no doubt would have preferred to take their chances on the street if they had had a choice.

Leaving free roaming dogs and cats where they were, though, may not have been a realistic option in most places. Before the advent of mass spay-neuter, shelter killing and fatal car strikes appear to have been the only significant checks (outside of environmental limitations) on the growth of the population of free roaming cats and dogs. The fact that animal complaints were the most frequent of all complaints made to city mayors in 1974 indicates that citizens would not have been happy with a laissez-faire attitude toward free roaming pets. And public health officials had good reason to be concerned about the health risks to people presented by free roaming animals. In the absence of any non-lethal alternative, it is unlikely that city officials or the general public would have allowed municipal shelters to simply turn animals away in order to avoid killing them.

Society’s harsh treatment of dogs in the 1800s was a reminder of what could happen when people feared dogs and cats more than loved them. People who were concerned about the welfare of dogs and cats in the 1970s and 1980s were facing a problem with no easy solution.⁷⁶

⁷⁶ Several European countries also had problems with the number of unowned dogs and cats in the 1970s. Josef König, “Surplus Dogs and Cats in Europe,” chap. 8 in *The Handbook of Animal Welfare*, 81–92.

Chapter 9: A Simple Surgery

As the population of free roaming cats and dogs was reaching crisis levels in the United States in the early 1970s (see chapter 8), veterinary medicine was developing a partial solution to the problem—safe, practical sterilization methods that could be incorporated into routine veterinary practice. Although we think of sterilization surgeries for cats and dogs as relatively simple and routine procedures today, that was not always the case. The techniques for doing spaying of the female and neutering (also called “castration”) of the male have been known for centuries, but it was not until the 1960s and 1970s that attitudes of pet owners and surgical techniques used by veterinarians developed to the point where sterilization could become a practical solution to pet overpopulation.



Figure 29:
In the Civil War, farriers were expected to treat horses, as well as shoe them. From “The Photographic History of the Civil War.” Public domain.

The veterinary profession has a long history. The term “veterinarian” was used in print as far back as the 1640s, and veterinary schools were founded in several European countries in the latter half of the 18th century.¹ The profession was slower to develop in the United States, and until the latter part of the 19th century many people who provided medical care for animals were self-trained “cow doctors” or “horse doctors.”² Robert Jennings, a medical doctor who was interested in veterinary training, described self-trained veterinarians in the United States in the mid-1800s as illiterate and intemperate men whose treatments for animals were based on ignorance and superstition.³ Before the advent of veterinary colleges in the United States, the most qualified veterinarians were medical doctors and people who had trained in European veterinary universities, or

had served apprenticeships with those veterinarians.⁴

¹ Robert Dunlop and David Williams, *Veterinary Medicine: An Illustrated History* (St. Louis: Mosby, 1996), 319–349; J. Fred Smithcors, *The American Veterinary Profession: Its Background and Development* (Ames: Iowa State University Press, 1963), 11. The first veterinary school was founded in France in 1761. “World Veterinary Year: Celebrating 250 Years of Improving Animal and Human Health,” *American Veterinary Medical Association*, accessed April 14, 2017, Internet Archive, https://web.archive.org/web/20120126022509/http://www.avma.org/Vet2011/AVMA_WorldVetYear_SympBrochure_PR-7-5-11-FINAL.pdf.

² Susan Jones, *Valuing Animals: Veterinarians and Their Patients in Modern America* (Baltimore: Johns Hopkins University Press, 2003), 11–12.

³ Smithcors, *American Veterinary Profession*, 284.

⁴ Bert Bierer, *A Short History of Veterinary Medicine in America* (East Lansing: Michigan State University Press, 1955), 87.

The earliest veterinary schools in the United States were three private institutions founded in the 1850s. The first was the Veterinary College of Philadelphia, which was founded in 1852 by Jennings.⁵ It shut down in 1866 after years of struggling to attract students. The Boston Veterinary Institute lasted an even shorter time, opening in 1854 and closing by 1860.⁶ The only one of the three earliest veterinary schools to survive for a significant period was the New York College of Veterinary Surgeons, chartered in 1857 by another medical doctor, John Busteed.⁷ It operated until 1899. Several other private veterinary schools of varying quality were established in the latter half of the 1800s, but the failure rate was high.⁸ These 19th century private schools were almost all urban, and they focused on preparing their graduates to take care of the ubiquitous horses that were used for transportation of people and goods in cities in the 1800s.⁹



Figure 30:
Dr. Alexandre Liautard, a French veterinarian who emigrated to the U.S. and founded the U.S. Veterinary Medical Association. Public domain.

One step along the road to the professionalization of veterinary medicine in the United States occurred in June of 1863, when a group of 40 veterinarians from seven mostly east coast states met to form the United States Veterinary Medical Association.¹⁰ The organization was rechristened the American Veterinary Medical Association (AVMA) in 1898.¹¹ For the first several decades of the Association's existence no degree was required to join, but in 1913 the AVMA instituted a requirement that members had to be graduates of accredited veterinary schools.¹²

In the late 1800s and early 1900s, the locus of most veterinary training shifted from cities to rural areas, with profound consequences for the profession. Several agricultural ("land-grant") universities established veterinary colleges, beginning with Iowa State University in 1879.¹³ The veterinary colleges at land-grant universities were primarily concerned with the care of livestock. The predominance of the land-grant universities in veterinary education led to a literal distancing of the profession from the urban academic centers of human medicine and public health.¹⁴ The land-grant veterinary colleges nevertheless proved

⁵ Smithcors, *American Veterinary Profession*, 284–287; "Former Veterinary Medical Institutions in the United States," *American Veterinary Medical Association*, accessed March 13, 2017, https://www.avma.org/KB/Resources/Reference/Documents/former_us_vet_schools.pdf.

⁶ Smithcors, *American Veterinary Profession*, 217, 241–246; "Former Veterinary Medical Institutions in the United States."

⁷ George Cristensen, "Veterinary Medical Education: A Rapid Revolution," in Smithcors, *American Veterinary Profession*, 642.

⁸ "Former Veterinary Medical Institutions in the United States."

⁹ Philip Teigen, "Nineteenth-Century Veterinary Medicine as an Urban Profession," *Veterinary Heritage* 23, no. 1 (May 2000): 2–3.

¹⁰ "History of the AVMA," *American Veterinary Medical Association*, accessed March 3, 2017, <https://www.avma.org/About/WhoWeAre/Pages/history.aspx>; Smithcors, *American Veterinary Profession*, 295–301. A French-trained veterinarian, Alexandre Liautard, who was one of the founders of the USVMA, was also involved with establishing veterinary colleges in New York City and was the editor of the USVMA veterinary journal. Donald Smith, "150th Anniversary of Veterinary Education and the Veterinary Profession in North America," Part I, *Journal of Veterinary Medical Education* 37, no. 4 (2010): 319, doi:10.3138/jvme.37.4.317.

¹¹ "History of the AVMA."

¹² Ibid. The AVMA represented a majority of the profession by 1941. "One for the History Books: A Visual History of the AVMA's First 150 Years," *American Veterinary Medical Association*, July 1, 2013, <https://www.avma.org/News/JAVMANews/Pages/130715a.aspx>.

¹³ Donald Smith, "The 28 Veterinary Colleges in the United States, Part I," *Veritas DVM*, accessed March 15, 2017, <https://www.veritasdvmblog.com/the-28-veterinary-colleges-in-the-united-states-part-i-2/>; Bierer, *Short History of Veterinary Medicine*, 37–38, 88–89. Although Iowa State University was the first school to establish a college of veterinary medicine, Cornell University was the first school to have a professor of veterinary science. Smith, "150th Anniversary of Veterinary Education," Part I, 319. The early university veterinary schools that were not land-grant were the ones at the University of Pennsylvania, Tufts University, Western University of the Health Sciences, and Tuskegee University. Smith, "150th Anniversary of Veterinary Education," Part I, 325–326nq.

¹⁴ Smith, "150th Anniversary of Veterinary Education," Part I, 320.

more successful and longer-lasting than the private urban veterinary schools, which were driven out of business in the early 1900s by competition from the land-grant schools and the replacement of the horse by the internal combustion engine.¹⁵ The rapid change in the nature of veterinary practice caused by the advent of the automobile can be seen in AVMA membership surveys that showed treatment of horses making up 80% of members' work in 1900, but only 10% in 1920 and 19% in 1931.¹⁶ By 1927, the private veterinary schools in the United States had closed, and the university veterinary colleges were firmly in control of veterinary education.¹⁷



Figure 31:
New York State Veterinary College, circa 1898. Public domain.

The reorientation of the veterinary profession away from the urban horse and toward agriculture was further strengthened by the Bureau of Animal Industry (BAI), a federal agency that employed many veterinarians during its existence from 1884 to 1953 within the U.S. Department of Agriculture.¹⁸ The BAI was concerned with promoting economic uses of animals and was heavily involved in meat inspection and the control of several devastating diseases of livestock.¹⁹ The dominance of the land-grant colleges in veterinary education and the emphasis on livestock, as

reinforced by the BAI, led to the profession's academic leadership placing less emphasis on small-animal medicine.²⁰

Despite the relative lack of interest in companion animals shown by academic leaders of the veterinary profession, urban veterinarians found that they could have viable practices treating small animals.²¹ As horses disappeared from cities, veterinarians could support their practices and bolster their professional reputations by treating dogs.²² A non-veterinarian who treated dogs noted in 1881 that people were willing to make "any sacrifice to save a pet dog."²³ Even poor people would find a way to pay for treatment of the family pet.²⁴

Urban pets, as relatively pampered animals accustomed to living in and around homes, required a different type of veterinary approach than livestock and horses. A small animal veterinarian had to have a

¹⁵ Cristensen, "Veterinary Medical Education," 646–647.

¹⁶ "One for the History Books."

¹⁷ Smith, "150th Anniversary of Veterinary Education," Part I, 318. A private veterinary school associated with the University of Massachusetts opened in 1938 and operated until 1947. Cristensen, "Veterinary Medical Education," 647.

¹⁸ Jones, *Valuing Animals*, 29–30, 110; Bierer, *Short History of Veterinary Medicine*, 45.

¹⁹ Smithcors, *American Veterinary Profession*, 479.

²⁰ Jones, *Valuing Animals*, 120, 122.

²¹ Philip Teigen, "Dogs, Consumers, and Canine Veterinarians, 1870–1900," *Veterinary Heritage* 35, no. 2 (November 2012), 47–48.

²² Smithcors, *American Veterinary Profession*, 502–503.

²³ *Ibid.*, 504.

²⁴ 50 Years of Educational Excellence and Practice Improvement (n.p.: American Animal Hospital Association, 1983), 5.

professional appearance, and pet owners expected gentler treatment for their pets than the wrangling used on large animals.²⁵

Some animal hospitals founded by non-profit humane organizations in the early 1900s offered small animal medicine as part of their services, including discounted or free care for the companion animals of poor people. The first such hospital had a modest start as a clinic in Manhattan. In 1910, Ellen Prince Speyer, the founder of the Women's Auxiliary of the ASPCA, spearheaded the establishment of a dispensary and clinic for treating animals whose owners could not afford care.²⁶ The dispensary provided care to over 6,000 animals in its first full year of operation, and the women realized that a larger facility was needed. They incorporated the New York Women's League for Animals, which was independent of the ASPCA, and raised funds for a hospital that opened in 1914. This hospital grew over the years to become a leader in veterinary research and education as well as direct animal care. It was renamed the Animal Medical Center in 1959.²⁷ The ASPCA opened its own dispensary in 1912 that grew into a respected veterinary department and hospital.²⁸

Another notable non-profit hospital was built by the Massachusetts SPCA in 1915 and named the Angell Memorial Hospital after George Angell, who had died in 1909.²⁹ The hospital had a "stray ward" where injured strays were taken in and treated.³⁰ The Angell Memorial Hospital developed advanced surgical protocols in the early 1930s, including the use of intravenous pentobarbital for anesthesia and careful sterile technique to prevent infection.³¹ Angell Memorial was ahead of the profession in its aseptic surgical techniques, and its procedures were not adopted by private veterinarians or even taught in veterinary schools for some time to come.³² An interesting note about Angell Memorial is that it never used animals in research.³³ Other non-profit organizations, including SPCAs and animal leagues in Philadelphia, Boston, San Francisco, Chicago, Los Angeles, and Cleveland, also opened free veterinary clinics by the mid-1920s.³⁴

A monthly newsletter that began publication in 1920, *The North American Veterinarian*, provided aspiring pet veterinarians with information about small animal practice.³⁵ Members of the AVMA organized a special section on small animals at the AVMA's 1925 meeting.³⁶ From 1922 to 1931 in New York City, the number of veterinarians whose practice was at least 75% in small animals grew from 47 to 126.³⁷ An AVMA survey of veterinarians in 1930 showed that 81% of the ones who responded reported that they treated pets, although treatment of pets occupied only 24% of their time on average.³⁸ In the 1930s, standardized

²⁵ Jones, *Valuing Animals*, 123, 129.

²⁶ "History," *Animal Medical Center*, <http://www.amcny.org/about-amc/history>.

²⁷ *Ibid.*

²⁸ Marion Lane and Stephen Zawistowski, *Heritage of Care: The American Society for the Prevention of Cruelty to Animals* (Westport, CT: Praeger, 2008), 78–84; Bernard Unti, "The Quality of Mercy: Organized Animal Protection in the United States, 1866–1930" (PhD diss., American University, 2002), 482.

²⁹ Unti, "Quality of Mercy," 482–484.

³⁰ Carter Luke, interview by author, April 30, 2014.

³¹ Dunlop and Williams, *Veterinary Medicine*, 611; Smith, "150th Anniversary of Veterinary Education," Part I, 322.

³² Dunlop and Williams, *Veterinary Medicine*, 611.

³³ *Ibid.*, 612.

³⁴ Sydney Coleman, *Humane Society Leaders in America* (Albany, NY: American Humane Association, 1924), 213.

³⁵ 50 Years of Educational Excellence, 47.

³⁶ Jones, *Valuing Animals*, 123.

³⁷ Smithcors, *American Veterinary Profession*, 588. An early veterinary practice devoted to small-animal care was opened by Harry Miller in 1903 in New York City. Veterinarian C.P. Zepp, Sr., who joined this practice in 1925, made it into an exemplary center for small-animal medicine that was often visited by other veterinarians as the popularity of small-animal medicine grew. Smith, "150th Anniversary of Veterinary Education," Part I, 322.

³⁸ Susan Jones, "Animal Value, Veterinary Medicine, and the Domestic Animal Economy in the United States, 1890–1930" (PhD diss., University of Pennsylvania, 1997), 265; "One for the History Books." The poll was conducted in 1930 and the results were reported in 1931.

vaccinations for both rabies and distemper became available,³⁹ and the advent of vaccinations gave veterinarians an additional foothold in companion animal practice. The editors of the journal *Veterinary Medicine* observed in 1935 that although veterinarians with livestock practices were struggling, small animal medicine was developing at a rapid pace.⁴⁰

A few private veterinarians had small animal hospitals as part of their practice before World War I.⁴¹ It was not until the late 1920s and early 1930s, though, that a significant number of veterinarians in private practice built hospitals designed specifically for small animals.⁴² Joseph Flynn, a veterinarian in Kansas City, Missouri, built a small animal hospital in 1915 that was regarded as a model.⁴³ He toured the country speaking to veterinary organizations in the 1920s, promoting small animal practice and hospital design.⁴⁴ Flynn was also known for developing a sutureless spaying technique for dogs, which he demonstrated to his audiences.

By 1933, there was enough interest in small animal hospitals that the American Animal Hospital Association (AAHA), which was dedicated to small animal practice, was founded.⁴⁵ About 100 veterinarians attended an informational meeting in August 1933, followed by formal organization in November. As of 1935, there were 19 hospital members of the new organization (up from only seven founding members in 1933).⁴⁶ The AAHA helped remedy the lack of instruction in small animal techniques with its publications and conferences.⁴⁷

Specialized veterinary care for pet cats was slower to develop than for pet dogs.⁴⁸ Louis Camuti set up the first veterinary practice devoted exclusively to cats in the 1930s.⁴⁹ A later proponent of feline medicine was Jean Holzworth, a 1950 Cornell graduate who worked at Angell Memorial Hospital.⁵⁰ There was sufficient demand from cat owners by the 1960s to support specialized hospitals for cats, and in the late 1960s and 1970s veterinary colleges began to pay more attention to feline medicine.⁵¹ The American Association of Feline Practitioners, which was established in 1971 with 25 members, had 200 members when it incorporated in 1974.⁵² By that time, small animal medicine was well on its way to being a dominant practice area in veterinary medicine. The percentage of AVMA members who listed themselves as small animal practitioners increased from 10% in 1954 to over half in 1990.⁵³

In addition to changes in the type of practice, veterinary medicine has seen a major change in its gender balance. Veterinary colleges in the 1930s favored applications from young men who had experience

³⁹ Jones, *Valuing Animals*, 130–133. Distemper epidemics affecting dogs in the American colonies were reported starting around 1760, and cat distemper appeared by 1796. Smithcors, *American Veterinary Profession*, 67, 151.

⁴⁰ Smithcors, *American Veterinary Profession*, 589.

⁴¹ Jones, "Animal Value," 264–265; Smithcors, *American Veterinary Profession*, 525–526.

⁴² Smithcors, *American Veterinary Profession*, 526.

⁴³ "KVCV Graduates 1892–1918," *Kansas State University College of Veterinary Medicine*, accessed April 15, 2017, <http://www.vet.k-state.edu/about/history/kvcv/graduate-bios.html>.

⁴⁴ Smithcors, *American Veterinary Profession*, 524–526.

⁴⁵ American Animal Hospital Association, *50 Years of Educational Excellence*, 8–9; Dunlop and Williams, *Veterinary Medicine*, 610–611.

⁴⁶ *50 Years of Educational Excellence*, 9, 13.

⁴⁷ *Ibid.*

⁴⁸ Dunlop and Williams, *Veterinary Medicine*, 615–617.

⁴⁹ Smith, "150th Anniversary of Veterinary Education," Part I, 322–323.

⁵⁰ Donald Smith, "150th Anniversary of Veterinary Education and the Veterinary Profession in North America: Part 2, 1940–1970," *Journal of Veterinary Medical Education* 38, no. 1 (2011): 94, doi:10.3138/jvme.38.1.84.

⁵¹ Jones, *Valuing Animals*, 136.

⁵² "The Mission and History of the AAFP," *American Association of Feline Practitioners*, accessed April 15, 2017, <http://www.catvets.com/about/mission-and-history>.

⁵³ "One for the History Books."

working with large animals on farms.⁵⁴ Discrimination on the basis of race⁵⁵ and religion⁵⁶ was common in veterinary college admissions, and discrimination on the basis of gender was almost universal.⁵⁷ In 1915, only four female veterinarians were listed in AVMA records as having active practices.⁵⁸ One study found that veterinary medicine was the most male-dominated of 34 professional categories in the period from 1910 to 1930 and remained among the most male dominated into the 1970s.⁵⁹ In 1960, the veterinary profession was 98% male.⁶⁰ By the 1969 to 1970 academic year, women made up 8.85% of students admitted to veterinary schools.⁶¹ Change was happening, but at a very slow pace.

In 1972, a federal law was enacted that, with a few exceptions, barred gender discrimination on the basis of sex in federally funded education programs.⁶² This law dramatically increased the pace of change, and in the years from 1972 to 1976 more women graduated from veterinary colleges than in the previous 70 years combined.⁶³ By the mid-1980s, approximately as many women were enrolling in veterinary school as men.⁶⁴ Since 2011, the AVMA has had more female than male members.⁶⁵ That year, 78% of veterinary students were female,⁶⁶ a reversal that has sparked comment about the feminization of the profession.⁶⁷ Progress in increasing racial diversity in veterinary medicine has lagged, however, and as of 2011 only about 10% of veterinarians in the workforce in the United States were non-Caucasian.⁶⁸

The pet overpopulation crisis that was recognized in the early 1970s had a major impact on small animal veterinary practitioners. Spaying and neutering are mainstays of veterinary practice today, but the surgeries were rare for dogs and cats until at least the 1930s.⁶⁹ Spaying of the female and castration of the male are different in their level of technical difficulty and in their risk to the animal. Castration of the male animal is a relatively straightforward surgery that does not involve cutting into the abdominal cavity. A veterinarian noted as far back as 1884 that castration of horses was one of the safest operations.⁷⁰ Spaying of the female is abdominal surgery and is far more complex.

⁵⁴ Smith, "150th Anniversary of Veterinary Education," Part I, 320–321.

⁵⁵ Billy Hooper, "The Aerial Mosaic: A Historical Picture of Diversity in Veterinary Medicine," in *Navigating Diversity and Inclusion in Veterinary Medicine*, ed. Lisa Greenhill et al. (West Lafayette, IN: Purdue University Press, 2013), 12–13, 15–24; Smith, "150th Anniversary of Veterinary Education," Part 2, 89, 96–97.

⁵⁶ Hooper, "Aerial Mosaic," 24; Smith, "150th Anniversary of Veterinary Education," Part I, 323–324.

⁵⁷ Smith, "150th Anniversary of Veterinary Education," Part 2, 90–96. Even when women were admitted to a veterinary school, they could be excluded from field work. Dana Peirce and Donald Smith, "A Biography of and Interview with Patricia Thomson Herr, DVM," *eCommons@Cornell*, June 12, 2010, 6, <http://ecommons.library.cornell.edu/bitstream/1813/17052/2/Herr%2c%20Patricia%20Thomson%2c%201960%2c%20BioInt.pdf>. In 1938 a prominent veterinarian expressed the view that the deans of veterinary schools might prefer to exclude the "weaker sex" because a "personable young woman," unlike a man who could be trained in her place, would be unlikely to remain in the profession during an entire working career. Smithcors, *American Veterinary Profession*, 538.

⁵⁸ "One for the History Books."

⁵⁹ Kim Weeden, "Profiles of Change: Sex Segregation in the United States, 1910–2000," chap. 5 in *Occupational Ghettos: The Worldwide Segregation of Women and Men*, ed. Maria Charles and David Grusky (Stanford: Stanford University Press, 2004), 163, table A5.1.

⁶⁰ Anne Lincoln, "The Shifting Supply of Men and Women to Occupations: Feminization in Veterinary Education," *Social Forces* 88, no. 5 (July 2010): 1976, doi:10.1353/sof.2010.0043.

⁶¹ Hooper, "Aerial Mosaic," 13.

⁶² 20 U.S.C. § 1681. See generally "Overview of Title IX of the Education Amendments of 1972, 20 U.S.C.A. § 1681 et. seq.," *United States Department of Justice*, accessed May 4, 2017, <https://www.justice.gov/crt/overview-title-ix-education-amendments-1972-20-usc-1681-et-seq>.

⁶³ Patricia Lowrie et al., "Origin of Coordinates: The Dilemma of Social Constructs," chap. 4 in *Navigating Diversity*, 46.

⁶⁴ Hooper, "Aerial Mosaic," 14; Lincoln, "Shifting Supply," 1977.

⁶⁵ "One for the History Books."

⁶⁶ Lowrie et al., "Origin of Coordinates," 46.

⁶⁷ Lincoln, "Shifting Supply."

⁶⁸ Hooper, "Aerial Mosaic," 26.

⁶⁹ Katherine Grier, *Pets in America: A History* (Chapel Hill: University of North Carolina, 2006), 80.

⁷⁰ Smithcors, *American Veterinary Profession*, 269.

A spaying technique for pigs and cows was known in the 15th and 16th centuries, and the procedure for sows was described in several colonial era publications in the United States and England.⁷¹ The innovative veterinarian George Dadd, in his 1850 book *American Cattle Doctor*, recommended the spaying of cows for improving the quality of their meat.⁷² His charge for the surgery was \$2.00 for heifers and \$3.00 for adult cows.⁷³ Dadd is also credited with being the first veterinarian in the United States to successfully spay horses.⁷⁴

Spaying of small animals seems to have been uncommon in the 1800s. An 1881 treatise on dogs stated that spaying of bitches was “almost unheard of” and was “inhuman and useless.”⁷⁵ Frank Billings, a prominent veterinarian in the late 1800s,⁷⁶ had a different view. He was certainly ahead of his time in anticipating the importance of spaying dogs, commenting that “it will tend to decrease the number of dogs.”⁷⁷ Billings reported that he had spayed “400 bitches of all ages,” with only one death. The death was caused not by the surgery itself but by the chloroform anesthetic, which led him to switch to ether.

One barrier to widespread adoption of spaying of dogs and cats was economic. Because spaying was abdominal surgery, it was expensive. An idea of the difference in the difficulty of spaying as opposed to castration can be gleaned from fees charged in 1936—an average of \$3.71 to castrate a cat versus \$10.57 to spay a dog (a price for castrating dogs was not given).⁷⁸ Another deterrent to sterilization was a common belief that the surgery was bad for the general health of an animal even beyond the dangers of the surgery itself.⁷⁹ A 1935 survey of 22 proprietors of veterinary hospitals showed that although most of them would recommend spaying a dog, 17 of them believed that there was some danger that spaying would make a dog fat and lethargic.⁸⁰

One of the technical difficulties in spay surgeries was the risk of infection. In the early 1900s, the lack of modern antibiotics, combined with a sometimes-careless approach to keeping the surgical site clean, meant that spaying had far more risk of infection than today.⁸¹ A veterinarian named Charles Saunders developed a model aseptic technique for spay surgery for dogs in 1915,⁸² and sterile techniques for small animal surgery became the standard method taught at veterinary colleges by the mid-1940s.⁸³ The first safe and effective modern antibiotic, penicillin, was mass produced for use in World War II. After the war ended, penicillin and several additional antibiotics became available for veterinary use.⁸⁴ By the early 1950s, the development of antibiotics and sulfa drugs had greatly reduced the incidence of infection as a complication of surgery.⁸⁵

⁷¹ Ibid., 121, 313. The spaying procedure for cows was forgotten and then rediscovered in 1831 when an American farmer was found practicing it.

⁷² Ibid., 221, 224.

⁷³ Ibid., 252.

⁷⁴ J.F. Smithcors, *The Veterinarian in America: 1625–1975* (Santa Barbara, CA: American Veterinary Publications, 1975), 61–62.

⁷⁵ Smithcors, *American Veterinary Profession*, 504–505.

⁷⁶ Ibid., 337.

⁷⁷ Ibid., 505–506.

⁷⁸ American Animal Hospital Association, *50 Years of Educational Excellence*, 14.

⁷⁹ Grier, *Pets in America*, 80.

⁸⁰ American Animal Hospital Association, *50 Years of Educational Excellence and Practice Improvement*, 13

⁸¹ Grier, *Pets in America*, 79.

⁸² Dunlop and Williams, *Veterinary Medicine*, 610.

⁸³ *50 Years of Educational Excellence*, 21; Andrew Messaro, “A Biography of and Interview with George E. Ross, Jr., DVM,” eCommons@Cornell, February 9, 2012, 11n12, <http://ecommons.library.cornell.edu/bitstream/1813/28694/2/Ross,%20George%20E.,%201960%20BioInt.pdf>.

⁸⁴ Jones, *Valuing Animals*, 97–98.

⁸⁵ Ibid.

Anesthesia was another important surgical consideration. In the early 1900s, there was no safe anesthesia agent for cats, and the anesthesia options for dogs were inadequate.⁸⁶ Veterinarians in the 1800s and early 1900s, therefore, frequently did surgery on unanesthetized animals.⁸⁷ Surgery on unanesthetized animals had to be done very quickly, leading to errors.⁸⁸

Many veterinarians had a lack of appreciation for animal pain. One 19th century veterinarian suggested that the primary reason to use anesthesia on veterinary patients was to relieve their owners' perceptions of pain.⁸⁹ Another argued that animals did not need anesthesia for most surgeries because they were not significantly influenced by the "nervous shock" that humans experience when subjected to surgery.⁹⁰ In 1898, a veterinarian physician identified anesthesia as a "neglected branch of veterinary medicine," wondering if the lack of interest in it reflected a lack of experience with the techniques or a low valuation assigned to animals.⁹¹ As late as 1920, a veterinarian decried the fact that veterinary medicine still lagged in its use of anesthesia, noting the bad impression made on pet owners by the cruelty of surgery without pain relief.⁹²

George Dadd, a leader in promoting spay surgeries for livestock, was also a leader in promoting the use of anesthesia for humane reasons.⁹³ Dadd used a mixture of ether and chloroform and recommended it in his writings in the mid-1800s.⁹⁴ But there were many difficulties with ether and chloroform, including danger to the people who administered them, the unpredictability of an animal's reaction to them, and the risk of killing the animal by an overdose.⁹⁵

Overdosing the patient was a particular concern, since veterinarians often worked alone and it was difficult to adequately monitor ether and chloroform dosing while also doing surgery.⁹⁶ In the 1930s veterinarians began to use epidural anesthesia and barbiturates.⁹⁷ Barbiturates, which were injected before surgery, were easier to use than inhaled agents such as ether or chloroform, but they had the disadvantage that there was no way to modify the dose once it was injected.

In the 1960s and early 1970s, medical doctors who specialized in human anesthesiology undertook the training of veterinarians at several universities across the United States.⁹⁸ This helped veterinarians learn to use the monitoring equipment developed for human anesthesiology.⁹⁹ The use of monitoring, combined with the availability of a new generation of inhalant anesthetics, greatly increased the safety of anesthesia, allowing veterinarians to quickly correct the dosage if an animal had too much or too little anesthesia. By

⁸⁶ Leo Lieberman, "Neutering Sexually Immature Animals," in *Overpopulation of Cats and Dogs: Causes, Effects, and Prevention*, ed. Marjorie Anchel (New York: Fordham University Press, 1990), 151.

⁸⁷ Ronald Jones, "A History of Veterinary Anesthesia," *Anales de Veterinaria* 18 (January 2002): 11–12; Dunlop and Williams, *Veterinary Medicine*, 610; Eugene Steffey, "A History of Veterinary Anesthesia," chap. 23 in *The Wondrous Story of Anesthesia*, ed. Edmond Eger, Lawrence Saidman, and Rod Westhorpe (New York: Springer, 2014): 293–295, 301, doi10.1007/978-1-4614-8441-7_23.

⁸⁸ Andrew Gardiner, "The Animal as Surgical Patient: A Historical Perspective in the 20th Century," *History and Philosophy of the Life Sciences* 31, no. 3–4 (2009): 357.

⁸⁹ Steffey, "History of Veterinary Anesthesia," 294.

⁹⁰ Smithcors, *American Veterinary Profession*, 362.

⁹¹ *Ibid.*, 384.

⁹² *Ibid.*, 545.

⁹³ *Ibid.*, 215, 217, 229–230, 253–254.

⁹⁴ *Ibid.*, 217.

⁹⁵ *Ibid.*, 186; Jones, "History of Veterinary Anesthesia," 9–12.

⁹⁶ Smithcors, *American Veterinary Profession*, 384.

⁹⁷ Steffey, "History of Veterinary Anesthesia," 296; Jones, "History of Veterinary Anesthesia," 12–13.

⁹⁸ "The History of the American College of Veterinary Anesthesiologists," *American College of Veterinary Anesthesia and Analgesia*, accessed May 4, 2017, <http://acvaa.org/docs/History>; Steffey, "History of Veterinary Anesthesia," 298–299.

⁹⁹ Steffey, "History of Veterinary Anesthesia," 298. One of the new inhalants was halothane, which was discovered in the 1950s and had the great advantage of being non-flammable. Jones, "History of Veterinary Anesthesia," 13–14.

1975, the AVMA had recognized anesthesiology as a specialty, and the American College of Veterinary Anesthesiologists was founded.¹⁰⁰

Modern techniques for spaying dogs and cats were not immediately recognized as a possible solution to the pet overpopulation problem described in chapter 8. In 1974, spaying was described at a major shelter industry conference as having so many drawbacks that alternatives, including chemical sterilization, should be sought.¹⁰¹ The difficulties cited included the need for a pre-operative examination, general anesthesia, cutting open the abdomen (with its greater risk of infection and concomitant requirement for careful sterile procedures), the need for an experienced surgeon, and care following surgery. The report noted that spaying was time consuming and expensive due to the requirements for a surgical suite and staff to assist the veterinarian. In 1976, a veterinarian at another national conference raised similar objections to sterilization of pets.¹⁰²

What was not foreseen in the early 1970s was how quickly the veterinary profession would develop the capability to do safe, low-cost, high-volume sterilization of dogs and cats. The next chapter discusses the development of major nationwide campaigns in the period from 1970 to 2000 to solve the pet overpopulation problem, including attacking the problem at its source by sterilizing cats and dogs. Those campaigns worked synergistically with the development of mass sterilization procedures by the veterinary profession in a concerted effort to solve the pet overpopulation problem.

¹⁰⁰ "History of the American College of Veterinary Anesthesiologists;" Steffey, "History of Veterinary Anesthesia," 301.

¹⁰¹ "Conclusions and Recommendations: Contraception," in *Proceedings of the National Conference on the Ecology of the Surplus Dog and Cat Problem, May 21–23, 1974* (Denver: American Humane Association, 1974), 118–119.

¹⁰² Robert Slobody, "Surgical-Neutering as a Pet Animal Population Reduction Tool," in *Proceedings of the National Conference on Dog and Cat Control, February 3–5, 1976* (Denver: American Humane Association, 1976), 222. A research veterinarian at the same conference characterized the "overall incidence of complications associated with spaying" as "relatively low." S. W. J. Seager, "Review of Reproduction Control in Cats and Dogs," in *Proceedings of the National Conference on Dog and Cat Control*, 229.

Chapter 10: Reducing Shelter Intake

When the pet overpopulation crisis came to the attention of the media in the early 1970s, the question was what to do about it. One possible reaction would have been for cities to redouble efforts to collect cats and dogs off the street and kill them. This approach may have been used in some cities, but there was a growing realization that it was impractical to try to round up and kill enough animals to reverse population growth.¹ Local governments were reluctant to spend the money that would have been needed to impound and kill all free roaming cats and dogs, and such programs would have been deeply unpopular with citizens, many of whom allowed their own pets to roam. A different approach was needed.

In the 1950s, the usual recommendation for preventing unwanted litters was to urge people to isolate their female pets during heat.² As techniques for sterilization surgeries became safer and more efficient (see chapter 9), sterilization was increasingly seen as a possible way to reduce the population of homeless cats and dogs. Friends of Animals, an organization founded in 1957 by Alice Herrington,³ was an early national leader in advocating for and subsidizing low-cost spaying and neutering.⁴ The Humane Society of the United States (HSUS) began to advocate for mass spaying and neutering in the 1960s.⁵

Kay Clausing, a New Jersey shelter official and humane advocate, wrote an article in 1966 that urged humane advocates to promote spay-neuter to pet owners and private veterinarians.⁶ She commented on the conundrum faced by shelter workers when adopting out unspayed females, and reported on the success of early-age spaying and neutering of cats and dogs as young as five weeks of age. Many shelter workers who were stressed and frustrated due to the large numbers of animals pouring into shelters became strong advocates for spaying and neutering.⁷

Most populations of free roaming dogs and cats are not isolated, but constantly have new members coming in from outside. Under these circumstances, neutering of males has little effect, and spaying of females is the key to reducing population.⁸ The percentage of female cats who must be spayed to achieve zero population growth may be higher than the percentage of female dogs.⁹ Pet sterilization campaigns were generally aimed equally at all cats and dogs, however.

¹ Baltimore appears to have been an example of a city where the dog control system did not reduce the number of free-roaming dogs, despite a substantial portion of the city's dogs going through the system each year. Alan Beck, *The Ecology of Stray Dogs: A Study of Free-Ranging Urban Animals* (1973; repr., West Lafayette, IN: Purdue University Press/NotaBell Books, 2002), 41.

² Bernard Unti, *Protecting All Animals: A Fifty-Year History of the Humane Society of the United States* (Washington, DC: Humane Society Press, 2004), 94.

³ "Who We Are: History," Friends of Animals, accessed March 15, 2017, http://friendsofanimals.org/about_us/who_we_are; Wolfgang Saxon, "Alice Herrington, 75, Founder of Friends of Animals, Is Dead," *New York Times*, April 28, 1994.

⁴ "Spay and Neuter Certificates," Friends of Animals, accessed June 25, 2017, <http://www.friendsofanimals.org/programs/spaying-neutering/spay-and-neuter-certificates>. An even earlier organization that supported spay-neuter was Mercy Crusade, which started providing assistance for sterilization in 1949 in the Los Angeles area. "Mercy Crusade's History," Mercy Crusade's Spay, Neuter & Wellness Clinic, accessed March 15, 2017, <http://www.dogcatfix.com/aboutus.html>.

⁵ Unti, *Protecting All Animals*, 94–95.

⁶ Kay Clausing, "Our Pet Population Explosion and Operation SPARED" in *The Humane Movement, 1966: Selected Discussion Papers of the National Leadership Conference of the Humane Society of the United States*, September 24–26, 1965, ed. R.J. Chenowith (Washington, D.C.: Humane Society of the United States, 1966): 32–26, http://animalstudiesrepository.org/cgi/viewcontent.cgi?article=1006&context=acwp_ca.

⁷ Douglas Fakkema, interview by author, May 21, 2015.

⁸ Carl Djerassi, Andrew Israel, and Wolfgang Jochle, "Planned Parenthood for Pets?," *Bulletin of the Atomic Scientists* 29, no. 1 (January 1973): 12, doi:10.1080/00963402.1973.11455434.

⁹ Andrew Rowan, "Animal Control, Animal Welfare, and Proposals for an Effective Program," in *Proceedings of the First New England Conference on Animals and Society* (Boston: Center for Animals, 1984), 43; Ann Manning and Andrew Rowan, "Companion Animal Demographics and Sterilization Status: Results from a Survey in Four Massachusetts Towns," *Anthrozoös* 5, no. 3 (1992): 197, doi:10.2752/089279392787011368.

The city of Los Angeles started a low-cost municipal spay-neuter clinic in February 1971,¹⁰ and adopted a differential licensing system that charged more to license unsterilized animals.¹¹ The clinic was available to any pet owner regardless of income and charged \$17.50 for a spay and \$11.50 for castration.¹² This initiative attracted a lot of attention, and by 1976, there were six low-cost clinics in California and a few clinics in other places.¹³

Despite the enthusiasm for these clinics, the spay-neuter movement faced considerable criticism in the early and mid-1970s. Some people argued that spay and neuter surgeries were not a practical method of birth control because they were costly and resource intensive.¹⁴ The campaign for more spay-neuter surgeries went forward not because everyone approved and was sure it would work, but because no one had come up with a non-surgical solution.¹⁵ A supporter of the low-cost spay-neuter effort pointed out in 1976 that state and local governments were increasingly turning to sterilization surgeries as an answer to the pet population crisis because no better alternative had been identified.¹⁶

Opposition to the early spay-neuter programs also came from private veterinarians who saw a threat to their business. Many in the veterinary profession felt that tax-supported spay-neuter clinics were unfair competition.¹⁷ Veterinary opposition grew so strong that one article characterized the result as “the war between the humane and veterinary communities.”¹⁸ In the 1980s, the struggle included court cases and an appeal to Congress to impose taxes on non-profits that engaged in unrelated business operations.¹⁹

One of the biggest questions faced by the early spay-neuter movement was whether there were enough veterinarians in the United States to do the volume of spaying and neutering that would be needed to control the pet population.²⁰ This question was answered in the affirmative by the development of new surgical



Figure 32:
Dr. Marvin Mackie. Photograph by Esther Mechler. Used with permission.

¹⁰ Theodore Sorich, “Reduced Cost for Surgical-Neutering Programs,” in *Proceedings of the National Conference on Dog and Cat Control, Feb. 3–5, 1976* (Denver: American Humane Association, 1976), 215. The clinic followed a pilot program that was started in August 1970. MVP Special Report, “Short Fuse on the Pet Population Bomb,” *Modern Veterinary Practice* 52, no. 3 (March 1971).

¹¹ Elisabeth Clancy and Andrew Rowan, “Companion Animal Demographics in the United States: A Historical Perspective,” in *The State of the Animals II: 2003*, ed. Deborah Salem and Andrew Rowan (Washington, DC: Humane Society Press, 2003), 15.

¹² MVP Special Report, “Short Fuse on the Pet Population Bomb.”

¹³ Sorich, “Reduced Cost for Surgical Neutering Programs,” 205; Rowan, “Animal Control,” 41, table 5.

¹⁴ See, e.g., Donald Mahan, “Veterinary Association Surgical-Neutering Programs,” in *Proceedings of the National Conference on Dog and Cat Control*, 203.

¹⁵ “Conclusions and Recommendations: Surgical Neutering Programs,” in *Proceedings of the National Conference on Dog and Cat Control*, 283.

¹⁶ Sorich, “Reduced Cost for Surgical Neutering Programs,” 204.

¹⁷ Unti, *Protecting All Animals*, 95; Djerassi, Israel, and Jochle, “Planned Parenthood for Pets?,” 13–14; David Drenan, “Limitations of Spay/Neuter Clinics,” in *Proceedings of the National Conference on the Ecology of the Surplus Dog and Cat Problem, May 21–23, 1974* (Denver: American Humane Association, 1974), 71; Clancy and Rowan, “Companion Animal Demographics in the United States,” 15.

¹⁸ Martha Armstrong, Susan Tomasello, and Christyna Hunter, “From Pets to Companion Animals,” in *The State of the Animals: 2001*, ed. Deborah Salem and Andrew Rowan (Washington, DC: Humane Society Press, 2001), 74.

¹⁹ *Ibid.*, 74–75; Unti, *Protecting All Animals*, 95.

²⁰ Djerassi, Israel, and Jochle, “Planned Parenthood for Pets?,” 14; Rutherford Phillips, “Animal Welfare Problems in the 1970s (American Humane Association Executive Director’s Annual Report),” in *Achieving Humanitarian Aims: Our Commitment—The American Humane Association 95th Annual*

techniques that reduced the time it took to do safe, high quality spay operations. Marvin Mackie, a veterinarian in private practice who cofounded several spay-neuter clinics in California from 1976 to 1982,²¹ was a pioneer in developing high volume spay procedures that did not sacrifice safety.²² That concept was developed and expanded into today's "high quality, high volume spay/neuter" (HQHVSN) clinics. The Humane Alliance, founded in 1994 in Asheville, North Carolina, has been a leader in training veterinarians in HQHVSN and mentoring the formation of HQHVSN clinics.²³

Some local governments passed ordinances in the early 1970s requiring shelters to spay and neuter animals before adopting them out,²⁴ but cost was a problem. When shelters raised adoption fees to compensate for the cost of sterilization, adoption rates could drop, at least temporarily. New York City and Charlotte both saw declines in adoptions after they enacted pre-adoption sterilization requirements.²⁵ A 1970 state law in California that required shelters to ensure sterilization of all cats before adoption correlated with increased killing of cats in shelters.²⁶



Figure 33:

Andrew Rowan and his dog, Charles. Used with permission of The Human Society of the United States.

Despite doubts about whether spay-neuter efforts would work, the evidence we have suggests that shelter intake started to decline around 1970. The decline was not uniform, but shelter statistics and surveys indicate it happened in a large number of cities and counties across the United States. Anecdotally, it was not just the number of dogs and cats going into shelters that began to decline, but also the number of homeless dogs and cats on the streets. In 1970 it was common to see dogs and cats in the streets. By the year 2000, that was much less common, at least in some places. A problem that had seemed intractable had begun to abate.

Andrew Rowan, Chief Scientific Officer of HSUS, has tracked animal shelter statistics for decades. He believes that "where sterilization was promoted, it was associated with a change in dog/cat intake."²⁷ Rowan found that estimates of shelter intake nationwide relative to human population showed "a big drop (40% or so) in the 1970s and then a leveling off in the 1980s."²⁸ In the 1990s, "dog intakes began a steady decline" and after the year 2000 "cat intakes began to decline."

Meeting, October 17–21, 1971 (Denver: American Humane Association, 1971), 11; Stephen Seager, "Review of Reproduction Control in Cats and Dogs," in *Proceedings of the National Conference on Dog and Cat Control*, 229.

²¹ "Bio/History," *QuickSpay—Spay Your Pet*, accessed March 15, 2017, <http://www.quickspay.com/bio.html>.

²² Philip Bushby, "The History of High Quality, High Volume Spay Neuter (HQHVSN)," lecture, ASPCA Cornell Maddie's Shelter Medicine conference (September 2016), accessed March 15, 2017, <http://www.maddiesfund.org/the-history-of-high-quality-high-volume-spay-neuter.htm>; "Welcome," *QuickSpay—Spay Your Pet*, accessed March 15, 2017, <http://www.quickspay.com/>.

²³ Humane Alliance was acquired by the ASPCA in 2015. "The ASPCA Acquires Humane Alliance, A National Pioneer in High-Quality, High-Volume Spay/Neuter Service and Training," *American Society for the Prevention of Cruelty to Animals*, accessed April 17, 2017, <https://www.aspc.org/about-us/press-releases/aspc-acquires-humane-alliance-national-pioneer-high-quality-high-volume>.

²⁴ William Hooper, "Municipal Animal Control Ordinances," in *Proceedings of the National Conference on Dog and Cat Control*, 114.

²⁵ Alexandra Wilson and Andrew Rowan, eds., *Animal Management and Population Control, What Progress Have We Made?* (Boston: Center for Animals, 1985), 21; Marion Lane and Stephen Zawistowski, *Heritage of Care: The American Society for the Prevention of Cruelty to Animals* (Westport, CT: Praeger, 2008), 40.

²⁶ George Crosier, "Controlling Animal Population: Population Control Through Legislation," in *Achieving Humanitarian Aims*, 129.

²⁷ Andrew Rowan, email message to author, November 17, 2016.

²⁸ *Ibid.*

What part did low-cost sterilization clinics play in the fall in shelter intake that started in the 1970s? The spread of low-cost clinics correlated with the fall in shelter intake, but Rowan does not think it was simply cause and effect. He believes that the clinics were part of a national debate about pet overpopulation that stimulated private veterinarians to begin offering spay-neuter surgeries to their clientele in order to avoid losing that segment of their business.²⁹ It appears to have been this entry into the field by private veterinarians that ultimately succeeded in pushing spay-neuter rates up to the point where the pet-population crisis began to abate.³⁰ A study in the early 1970s showed that the willingness of owners to get their pets spayed was extremely sensitive to cost.³¹ The reduced cost clinics may have led private veterinarians to lower their prices on the surgeries, which in turn made the surgeries more attractive to pet owners.³²

The motive for private veterinarians to do more spay-neuter surgeries in their practices may not have been entirely a matter of protecting themselves from the low-cost spay-neuter clinics. One veterinarian said at a 1974 conference that “until recently the vast majority of practicing veterinarians were unaware of the problem of overpopulation of pet animals.”³³ Competition from the clinics may have accelerated a trend that would have happened anyway as veterinarians realized they could help control the population of homeless cats and dogs.

In addition to a possible role of low-cost spay-neuter clinics in motivating private veterinarians to perform more sterilizations at lower cost, the publicity surrounding the clinics may have had the effect of educating the public about the importance of sterilizing their pets. An executive with the Peninsula Veterinary Medical Association noted in an editorial in a veterinary magazine in the 1970s that controversy over low-income spay-neuter clinics had increased people’s awareness of the pet-population issue.³⁴ As a result, the social acceptability of allowing a pet dog to have a litter was declining. A 2007 study showed that low-cost sterilization programs increased the number of regular-cost spay-neuter surgeries as well, perhaps because of the increased marketing of the benefits of sterilization.³⁵

If an increasing acceptance of sterilization as a part of health care for pets was behind the fall in shelter intake in the 1970s, and the fall in intake leveled off in the 1980s, what caused the renewed fall in dog intake in the 1990s and cat intake in the 2000s? Several factors were probably at work, but Rowan points to the fact that in the 1990s veterinarians began to recommend spay-neuter as part of a routine package of pet care, so that their clients had to opt out in order to avoid sterilizing their pets.³⁶ This differed from the 1970s, when veterinarians simply made spay-neuter available and clients had to opt in for the surgery.

Another factor that may have been important in the renewed fall in shelter intake in the 1990s was the increasing acceptance of pediatric spay-neuter (sterilization at as young as eight weeks of age). The prime breeding age for cats and dogs is one to three years.³⁷ A 1991 study that was done before the use of

²⁹ Andrew Rowan, interview by author, April 29, 2014; Andrew Rowan, “Animal Sheltering Trends in the U.S.: A Historical Lesson From—And For—U.S. Animal Shelters,” *Humane Society of the United States*, accessed March 15, 2017, http://www.humanesociety.org/animal_community/resources/timelines/animal_sheltering_trends.html?credit=web_id97546296.

³⁰ Rowan, interview.

³¹ Sorich, “Reduced Cost for Surgical Neutering Programs,” 207.

³² “Spay Clinics: The Other Side of the Story,” *Modern Veterinary Practice* (April 1973), 30; Robert Slobody, “Surgical-Neutering as a Pet Animal Population Reduction Tool,” in *Proceedings of the National Conference on Dog and Cat Control*, 222–223.

³³ Drenan, “Limitations of Spay/Neuter Clinics,” 72.

³⁴ Donald Dooley, “Take a Look at the Forest,” editorial, *Modern Veterinary Practice* (circa 1971), 2.

³⁵ Joshua Frank and Pamela Carlisle-Frank, “Analysis of Programs to Reduce Overpopulation of Companion Animals: Do Adoption and Low-Cost Spay/Neuter Programs Merely Cause Substitution of Sources?,” *Ecological Economics* 62, no. 3 (May 2007): 745, doi:10.1016/j.ecolecon.2006.09.011.

³⁶ Rowan, “Animal Sheltering Trends in the U.S.”

³⁷ Jacqueline Vaughn, “The Shelter Charade: The Dilemmas of Urban Animal Control,” in *State & Local Government Review* 10, no. 3 (September 1978), 87.

pediatric spay-neuter had become widespread showed that spayed female cats and dogs had 78% as many litters as unspayed females.³⁸ This happened because the females had not been spayed early enough in life to keep them from reproducing.

For the spay-neuter campaign to have maximum effect, it had to convince people to not only spay their female pets, but to spay them early in life before they had a litter. That was difficult. A tradition of waiting to do spaying and neutering on cats and dogs until they were six months old or older had started in the early 1900s, at a time when anesthesia was still primitive.³⁹ It was thought that adult animals, with their larger body size, were better able to tolerate the anesthetics in use at the time.⁴⁰ By the 1970s, sterilization surgeries were much safer, but the old tradition of waiting to six months of age for sterilization hung on.

Leo Lieberman, a veterinarian in private practice, was a pioneer in advocating for pediatric spay-neuter. Lieberman published a letter on pediatric spay-neuter in 1982 that reported good results with sterilization of over 100 puppies and kittens at 8 to 10 weeks of age.⁴¹ In 1987, he published a widely read article about the safety and advantages of pediatric sterilization.⁴² Marvin Mackie was also a proponent of early age spay-neuter. He began doing early age spay-neuter in 1988 and found that puppies and kittens tolerated the surgery well.⁴³ Acceptance of pediatric spay-neuter grew rapidly in the 1990s.⁴⁴

Early age spay-neuter helped solve a problem that had been bedeviling shelters, which was what to do with puppies and kittens who were too young (under the old rule of waiting until at least six months of age before sterilization) to be spayed or neutered before adoption. Shelters had tried requiring adopters to sign a contract promising to get their new pet sterilized when the pet was old enough, but that was not very effective. The National Animal Control Association reported in the 1980s that up to 70% of owners failed to carry out the promised sterilizations.⁴⁵ In 1987, the ASPCA, which offered free spaying and neutering for adopted puppies and kittens when they reached six months of age, was reported to have had as low as a 20% to 30% response rate to their program.⁴⁶ Another shelter reported that even when the entire cost of sterilization surgery was collected at the time of adoption, 30% of puppy and kitten adopters failed to follow up and have the surgery performed.⁴⁷

Shelters were under considerable pressure starting in the 1970s not to add to the pet overpopulation problem by adopting out animals who could breed,⁴⁸ and some shelters reacted to this difficult situation by simply killing all puppies and kittens who were under six months of age rather than adopting them out

³⁸ Manning and Rowan, "Companion Animal Demographics and Sterilization Status," 197, table 3.

³⁹ Leo Lieberman, "Neutering Sexually Immature Animals," in *Overpopulation of Cats and Dogs: Causes, Effects, and Prevention*, ed. Marjorie Anchel (New York: Fordham University Press, 1990), 151.

⁴⁰ Ibid.

⁴¹ Leo Lieberman, "Advantages of Early Spaying and Neutering," *Journal of the American Veterinary Medical Association* 181 (1982), 420–422. Some shelters had started doing pediatric spay-neuter even earlier, in the 1970s. Lieberman, "Neutering Sexually Immature Animals," 157; Leslie Appel and Janet Scarlett, "Pediatric Neutering," in *Shelter Medicine for Veterinarians and Staff*, 2nd ed., ed. Lila Miller and Stephen Zawistowski (Ames, IA: Wiley-Blackwell, 2013), 647.

⁴² Leo Lieberman, "A Case for Neutering Pups and Kittens at Two Months of Age," *Journal of the American Veterinary Medical Association* 191, no. 5 (September 1987): 518–521.

⁴³ "Bio/History," QuickSpay—Spay Your Pet.

⁴⁴ For an evaluation of the risks and benefits of pediatric spay-neuter surgeries, see Appel and Scarlett, "Pediatric Neutering," 651–658.

⁴⁵ Lieberman, "Neutering Sexually Immature Animals," 150.

⁴⁶ "Editor's Notes," Appendix B in *Overpopulation of Cats and Dogs*, 243.

⁴⁷ Lieberman, "Neutering Sexually Immature Animals," 150.

⁴⁸ "Conclusions and Recommendations, Chemical and Mechanical Reproduction Control," in *Proceedings of the National Conference on Dog and Cat Control*, 267; Rutherford Phillips, "Problems of Euthanasia and Adoption," in *Proceedings of the National Conference on the Ecology of the Surplus Dog and Cat Problem*, 52.

unsterilized.⁴⁹ The ability to sterilize puppies and kittens before they went out the door took away what had been a serious obstacle to their adoption.

In addition to the increased acceptance of pediatric spay-neuter, another factor in the renewed decline in shelter intake in the 1990s may have been further growth in the availability of low-cost spay-neuter programs for owned pets. In 1990, Esther Mechler founded SpayUSA to serve as a nationwide referral center for low-cost spaying and neutering.⁵⁰ The SpayUSA referral procedure was a streamlined version of the Friends of Animals approach.⁵¹ Instead of collecting the discounted spay-neuter fee from the clients and then paying the providers as Friends of Animals did, SpayUSA arranged with providers for a discounted fee and then referred clients to them directly. This approach proved so popular that Mechler could not keep up with the number of calls that SpayUSA received.⁵² In 1993, North Shore Animal League took over SpayUSA and provided a telephone center and full-time referral agents to answer calls. Mechler continued to manage the program for the next 17 years.⁵³ She was a popular speaker at conferences and helped many people develop local programs.



Figure 34:
The SpayUSA concept is not limited to the USA. This spay-day event was held by SpayPanama, which was founded by Patricia Chan. Photograph used with permission of SpayPanama.

Another consequential event in the 1990s was a conference held by the International Society for Animal Rights in Washington, DC, in September of 1991 on the current state of efforts to manage pet overpopulation.⁵⁴ The conference included presentations on mandatory spay-neuter, pediatric spay-neuter, trap-neuter-return programs for feral cats, pet-population issues as part of the veterinary curriculum, the effect of purebred dog breeding on the dog population, and prospects for non-surgical sterilization.

Barbara Carr and Peter Marsh of New Hampshire attended the 1991 conference. Carr was a shelter director in Dover at that time and she was interested in identifying ways to reduce shelter intake.⁵⁵ Marsh was a New Hampshire attorney who was working on state legislative initiatives for animal welfare.⁵⁶ They heard Arthur Baeder, a veterinarian from New Jersey, speak at the conference about New Jersey's

⁴⁹ Lieberman, "Neutering Sexually Immature Animals," 150.

⁵⁰ Esther Mechler, interview by author, February 25, 2016.

⁵¹ Ibid.

⁵² The number of calls fluctuated with publicity. In May 1993, Mechler received 23,000 calls after an article about SpayUSA appeared in *Cat Fancy* magazine. Calls also increased when SpayDay USA was established in 1995 by the Doris Day Animal League. Mechler, interview.

⁵³ Ibid.

⁵⁴ International Society for Animal Rights, *Special Report: Killing the Crisis, Not the Animals* (Clarks Summit, PA: International Society for Animal Rights, 1991).

⁵⁵ Peter Marsh, interview by author, February 20, 2014.

⁵⁶ Ibid.

state-subsidized program for spaying and neutering the pets of low income people at very low cost.⁵⁷ That same year Carr did a study on kitten intake at her shelter and found that 48% of people who surrendered litters of kittens had incomes below the poverty line, even though the poverty rate in the county was only 12%.⁵⁸

New Hampshire had various pet sterilization programs at that time that reduced the cost of spaying and neutering by about half, but Carr and Marsh realized that was still too much for poor families to pay.⁵⁹ They succeeded in getting the state to adopt a program for subsidized cat and dog sterilization where pet owners with poverty level incomes had to pay only \$10.00.⁶⁰ The program took effect in 1994. Between 1994 and 2000, the yearly intake of cats and dogs at New Hampshire shelters fell from 18,388 to 12,800.⁶¹ The fall in intake in New Hampshire may not have been due to the spay-neuter effort alone,⁶² but the fact that reasonably accurate intake statistics were available for the state and showed a steep decline attracted interest to the New Hampshire program and the importance of very-low-cost and free spay-neuter services.

The percentage of pets who are sterilized appears to have trended up sharply in the United States since 1970. Surveys of sterilization rates for owned pets in the 1970s produced widely varying results, perhaps reflecting differences from one location to another, or differing survey methodologies. A nationwide survey by the Pet Food Institute in 1975, after the spay-neuter movement had been underway for a few years, found that 47% of female dogs but only 12% of male dogs had been sterilized.⁶³ For cats, 31% of females and 38% of males had been sterilized. Recent surveys show a greatly improved picture. The American Pet Products Association estimated that in 2012, 83% of owned dogs were sterilized (up from 72% 10 years earlier) and 91% of owned cats were sterilized (up from 84% 10 years earlier).⁶⁴

A concept that attracted much interest in the 1970s was chemical birth control. A 1973 article proposed that chemical birth control might solve what was then believed to be a problem of not enough veterinarians to do spay-neuter surgeries.⁶⁵ The authors of the article argued that owners would be more willing to accept chemical birth control than sterilization because chemical birth control did not involve a large up-front cost and could potentially be reversible.⁶⁶ Chemical birth control, although it was regarded as a great hope in the 1970s,⁶⁷ did not develop as quickly as its proponents had expected.⁶⁸ The rapid development of safer and more efficient surgical sterilization techniques took away some of the perceived need for developing chemical birth control.

⁵⁷ Ibid. For a discussion of the New Jersey program, see Sharon Secovich, "Case Study: Companion Animal Over-Population Programs in New Jersey, New Hampshire, and Maine and a New Program for Maine," August 2003, 15–21, accessed April 16, 2017, http://www.spayusa.org/assets/pdfs/study_three_state_programs.pdf.

⁵⁸ Marsh, interview.

⁵⁹ Peter Marsh, *Getting to Zero: A Roadmap to Ending Pet Overpopulation in the United States* (Concord, NH: Town and Country Reprographics, 2012), chapter 2, accessed April 16, 2017, http://www.shelteroverpopulation.org/Getting_To_Zero.htm.

⁶⁰ Ibid. The program also included subsidized sterilization for cats and dogs adopted from shelters.

⁶¹ Peter Marsh, email message to author, March 2, 2014.

⁶² See the discussion on New Hampshire in chapter 17.

⁶³ Robert Wilbur, "Pets, Pet Ownership and Animal Control: Social and Psychological Attitudes, 1975," in *Proceedings of the National Conference on Dog and Cat Control*, 22.

"Spay Clinics: The Other Side of the Story."

⁶⁴ "APPA National Pet Owners Survey 2013–2014" (Greenwich, CT: American Pet Products Association, 2014), 72, 177.

⁶⁵ Djerassi, Israel, and Jochle, "Planned Parenthood for Pets?," 14.

⁶⁶ Ibid., 13–14.

⁶⁷ Phillips, "Animal Welfare Problems in the 1970s," 11–12.

⁶⁸ Unti, *Protecting All Animals*, 95–96; Lieberman, "Neutering Sexually Immature Animals," 152; Wolfgang Jochle, "Chemosterilants" in *Overpopulation of Cats and Dogs*, 164–165.

Sterilization was the first of two major campaigns that gained momentum in the 1970s to solve the pet overpopulation problem. The second campaign, which got underway around the same time as the spay-neuter effort, was to persuade or require people to keep their pets off the streets by keeping cats indoors and confining dogs to their property or walking them on leashes. The effect of this second campaign is even harder to quantify than the effect of spay-neuter. But it did lead to a considerable cultural change in how people regarded free roaming dogs and, to a lesser extent, cats.

To succeed, the campaign to get cats and dogs off the streets had to change the perception among many pet owners that it was acceptable to allow their animals to roam. Since colonial times, pet owners in the United States had typically allowed their cats and dogs outdoors for at least part of the day to roam about as they pleased. As shown by several field studies of free roaming animals, this practice was still very common in the 1970s.⁶⁹ Alan Beck's Baltimore study in the early 1970s, for example, found that at least 37% of owned dogs were allowed to roam and that it was common in the morning and evening to see people letting their dogs out to run.⁷⁰ A 1975 Sacramento study found that 71% of free roaming dogs wore collars, indicating that they were owned and their owners were simply letting them roam.⁷¹

The authors of a study done in Manhattan, Kansas observed that pet owners who did not allow their female dogs to roam were generally not contributing to the dog population problem whether the dogs were spayed or not.⁷² Beck pointed out that having dogs leashed could not only solve the dog overpopulation problem but also stop the nuisance and public-health problems caused by roaming dogs.⁷³

The twin needs for sterilization of pets and keeping pets off the street were behind a program called LES (Legislation, Education, and Sterilization) developed by HSUS in the early 1970s.⁷⁴ The LES program was promoted by Phyllis Wright, director of HSUS's Animal Sheltering and Control department.⁷⁵ The concepts behind the LES program were discussed at two national conferences on the pet-overpopulation problem held in 1974 and 1976.⁷⁶ The LES program, with its slogan that "LES is more" became a central focus in animal sheltering.⁷⁷

The legislation portion of the LES program was aimed at modernizing laws affecting companion animals, especially animal control ordinances. Animal control ordinances were made at the local level and varied widely, leading to what one commentator in 1976 called a "hodgepodge" of different procedures in different places.⁷⁸ An animal control superintendent from Albuquerque noted at a 1971 conference that most of the towns and hamlets in New Mexico had no animal control ordinances for pets.⁷⁹ The simplest animal control

⁶⁹ See chapter 8.

⁷⁰ Beck, *Ecology of Stray Dogs*, 4.

⁷¹ William Westbrook and Robert Allen, "Animal Field Research," chap. 12 in *The Handbook of Animal Welfare: Biomedical, Psychological, and Ecological Aspects of Pet Problems and Control*, ed. Robert Allen and William Westbrook (New York: Garland STPM Press, 1979), 152, 164.

⁷² R. Nassar and J. E. Mosier, "Canine Population Dynamics: A Study of the Manhattan, Kansas, Canine Population," *American Journal of Veterinary Research* 41, no. 11 (November 1980): 1802.

⁷³ Alan Beck, "The Ecology of Urban Dogs," chap. 6 in *Handbook of Animal Welfare*, 54.

⁷⁴ Andrew Rowan and Jeff Williams, "The Success of Companion Animal Management Programs: A Review," *Anthrozoös* 1, no. 2 (1987): 110, doi:10.2752/089279388787058623; Unti, *Protecting All Animals*, 92.

⁷⁵ Rowan and Williams, "Success of Companion Animal Management Programs," 110.

⁷⁶ The conferences were sponsored by the American Humane Association, HSUS, the AMVA, the American Kennel Club, and the Pet Food Institute. *Proceedings of the National Conference on the Ecology of the Surplus Dog and Cat Problem; Proceedings of the National Conference on Dog and Cat Control*; Richard Marshall, "The United States of America Conferences," chap. 10 in *Handbook of Animal Welfare*, 119–126. HSUS president John Hoyt was instrumental in arranging the 1974 conference. Rowan and Williams, "Success of Companion Animal Management Programs," 110.

⁷⁷ John Wenstrup and Alexis Dowidchuk, "Pet Overpopulation: Data and Measurement Issues in Shelters," *Journal of Applied Animal Welfare Science* 2, no. 4 (1999): 311, doi:10.1207/s15327604jaws0204_5.

⁷⁸ Hooper, "Municipal Animal Control Ordinances," 106.

⁷⁹ E. V. Hughey, "Animal Control," in *Achieving Humanitarian Aims*, 31.

ordinances in the United States in the mid-1970s generally applied only to free roaming dogs, not cats.⁸⁰ In larger cities, ordinances were likely to be more comprehensive and have provisions such as impoundment and reclamation fees that increased with the number of violations.⁸¹ Ordinances in the 1970s were heavily weighted toward protecting people from nuisances and diseases caused by animals, and few of them contained provisions for animal welfare.⁸²

Many jurisdictions enacted new or revised animal control ordinances in reaction to the pet overpopulation crisis of the 1970s.⁸³ HSUS developed a proposed model ordinance that included a leash law and mandatory licensing for dogs and cats.⁸⁴ Leash laws that were enacted throughout the country in the 1970s helped change the public perception that allowing dogs to roam was acceptable. Today, we take it for granted that in most urban and suburban areas dogs must be under their owners' control, and this change in the culture largely correlated with the passage and enforcement of leash laws.

Recommended control measures in the 1970s were somewhat different for dogs and cats. Dogs can be walked on leashes, and many dogs can be trained to be reliable under voice control off lead. Cats are not usually leashed, and are not easy to confine with a fence. The lack of effective options for maintaining control of cats outdoors resulted in recommendations for making cats indoor-only animals, a step that many cat owners were reluctant to take.

The "education" aspect of LES was designed to emphasize the importance of sterilization and owner responsibility, and was part of the broader effort on the part of humane advocates to increase awareness of the need for pet sterilization.⁸⁵ Barbara Cassidy of HSUS described at a 1987 conference some of the marketing efforts that shelters were making to encourage owner responsibility and sterilization.⁸⁶ One of her examples was a campaign created by the Massachusetts SPCA, which was a leader in humane education dating back to the 1800s. The program used newspaper advertisements and posters with messages such as: "Surprise! Your four-year-old is the grandfather of 173."⁸⁷

Another type of promotion was designed to get attention by informing the public about the extent of shelter killing. Shelters had traditionally downplayed how much killing they were doing, but by the 1980s many people in the shelter industry felt that this silence was harmful to the cause of pet population control.⁸⁸ In the early 1990s, officials of the Peninsula Humane Society in California invited the media into the euthanasia room to witness animals being killed.⁸⁹ A less graphic version of this approach was the "chain of collars" vigil, where each collar represented an animal killed at a shelter.⁹⁰

⁸⁰ Hooper, "Municipal Animal Control Ordinances," 107.

⁸¹ Ibid.

⁸² Ibid., 110, 114.

⁸³ Rowan and Williams, "Success of Companion Animal Management Program," 111; Barbara Cassidy, "Who is Responsible for Pet Overpopulation?," in *Overpopulation of Cats and Dogs*, 42.

⁸⁴ Other provisions included a requirement for tags to be worn on collars, differential pricing for licenses based on spay-neuter status, a requirement that all animals adopted from a shelter be sterilized, a requirement for pet owners to pick up dog feces, a requirement that animal-handling facilities be licensed, and provisions for proper care of pets. Thomas Durkin, "Human Relations and Public Relations as They Relate to Animal Control," in *Proceedings of the National Conference on Dog and Cat Control*, 160; Unti, *Protecting All Animals*, 92.

⁸⁵ Cassidy, "Who is Responsible for Pet Overpopulation?," 43, 49–50.

⁸⁶ Ibid., 50.

⁸⁷ Ibid.

⁸⁸ Gordon Robinson, "Euthanasia: Agents Used; Public Perception; Stress on Technicians," panel discussion in *Overpopulation of Cats and Dog*, 78–79; B. J. Ellis, *Paws for Thought: A Look at the Conflicts, Questions and Challenges of Animal Euthanasia* (Columbia, SC: Paw Print Press, 1993), 22–23.

⁸⁹ Ellis, *Paws for Thought*, 73; "Euthanasia in the Public Eye" *Animal Sheltering*, March 1992, 25.

⁹⁰ Marsh, interview.

The “sterilization” aspect of LES encouraged differential licensing, low-cost spay-neuter programs, and sterilization or sterilization contracts for all animals placed by shelters.⁹¹ Differential licensing charged significantly more to license an unsterilized animal than a sterilized one. A differential licensing program in Los Angeles in the 1970s correlated with a sharply increased sterilization rate of licensed animals.⁹²

LES was just one of many programs promoting spay-neuter, but it was a leader in advocating for pets to be kept at home or under their owner’s supervision. LES may have had its greatest impact in helping to change the culture to make it less acceptable to allow dogs and cats to roam.

Mandatory sterilization ordinances were another popular idea in the period from 1970 to 2000. A 1998 survey of 186 shelters found that shelter managers named mandatory sterilization as the most important and effective type of program for reducing pet overpopulation.⁹³ There was considerable sentiment in those days for emphasizing penalties, rather than persuasion in animal control ordinances, because people felt that persuasion had been tried and had not worked.⁹⁴ Today, mandatory sterilization ordinances are thought by many animal-control experts to be ineffective or even counterproductive, as people who do not want to sterilize their pets will simply avoid licensing them.

Programs to sterilize owned pets and ordinances requiring owned pets to be kept off the street do not directly target homeless cats and dogs. Even so, the number of feral and unowned dogs decreased from an estimated 20% of the total dog population in 1969 to a very small number as of 1995.⁹⁵ Beck has suggested that unowned dogs do not have a high rate of reproductive success and that maintaining their population requires input from the owned dog population.⁹⁶ Thus, a decrease in the number of litters born to owned dogs may eventually cause the population of unowned dogs to decline. It is not clear whether the free-roaming cat population declined from 1970 to 2000. Shelter intake of cats appears to have declined substantially during that time, but cat intake is not necessarily an accurate reflection of cat populations since impoundment policies for cats can vary a great deal from one place to another and from one time to another.

In addition to an increasing percentage of sterilized pets and a decreasing acceptance of allowing pets to roam, a change in how people valued their pets may have been a factor in the fall in shelter intake from 1970 to 2000. There are anecdotal reports from some people who were active in the shelter industry in the 1970s and 1980s that people became more reluctant to surrender pets to shelters for trivial reasons. The phenomenon of changing attitudes toward pets is discussed at more length in the next chapter, but it appears as though for an increasing number of people in the 1970s and 1980s it was no longer a casual matter to surrender a pet to the shelter.

⁹¹ Rowan and Williams, “Success of Companion Animal Management Programs,” 110; Cassidy, “Who is Responsible for Pet Overpopulation?,” 43.

⁹² Clancy and Rowan, “Companion Animal Demographics in the United States,” 15; Rowan and Williams, “Success of Companion Animal Management Programs,” 119.

⁹³ Wenstrup and Dowidchuk, “Pet Overpopulation,” 312, table 9.

⁹⁴ Rowan and Williams, “Success of Companion Animal Management Programs, 110-111; Cassidy, “Who is Responsible for Pet Overpopulation?,” 42.

⁹⁵ Gary Patronek and Andrew Rowan, “Determining Dog and Cat Numbers and Population Dynamics,” editorial, *Anthrozoös* 8, no. 4 (1995): 202.

⁹⁶ Beck, “Ecology of Urban Dogs,” in *Handbook of Animal Welfare*, 52.

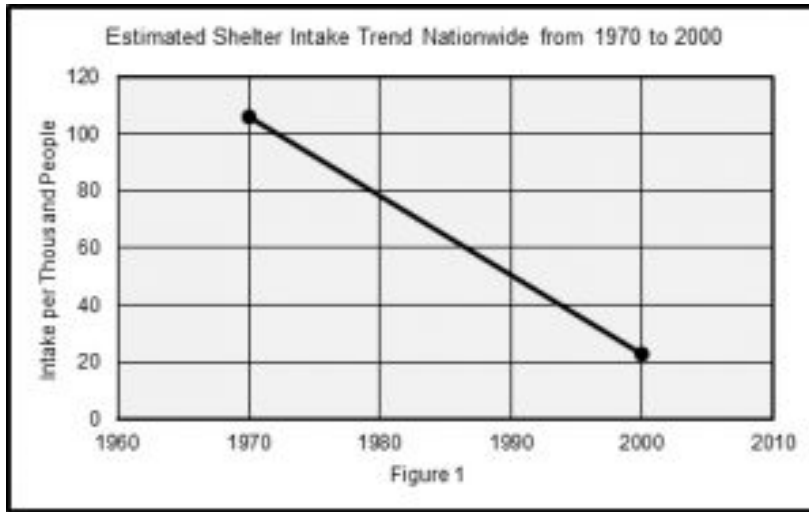

The fall in shelter intake that happened in the years from 1970 to 2000 set the stage for shelters to begin to raise their live release rates and finally reduce shelter killing. This effort was aided by the fact that, while shelter intake was declining, the number of people in the United States was increasing, thus providing more potential homes for those shelter animals. Shelter statistics such as intake and disposition are often reported “per thousand people,” to reflect the fact that the size of the

population served by a shelter is a relevant variable when looking at shelter performance.

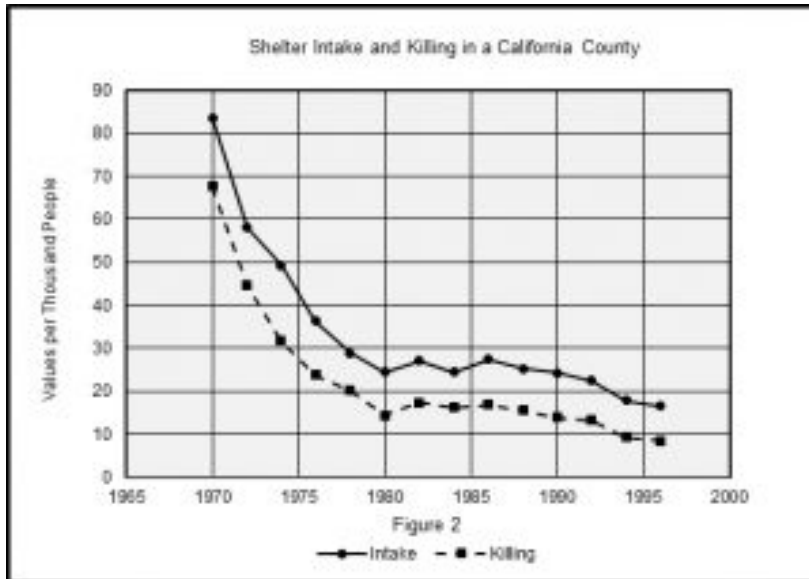

Most experts agree that by the year 2000 annual shelter intake in the United States was around seven million cats and dogs, or about 23 per thousand people. Estimates for nationwide shelter intake in the 1970s and 1980s vary, and the 1970 intake number per thousand people in Figure 1 is based on an average of those estimates. Whether a low or high intake estimate is used for 1970, though, the trend in intake between 1970 and 2000 is sharply down. Figure 1 shows estimated shelter intake per thousand people from 1970 to 2000. Figure 1 is derived

from estimates that have a good deal of uncertainty, and the downward trend was probably not as uniform as it appears in the graph.

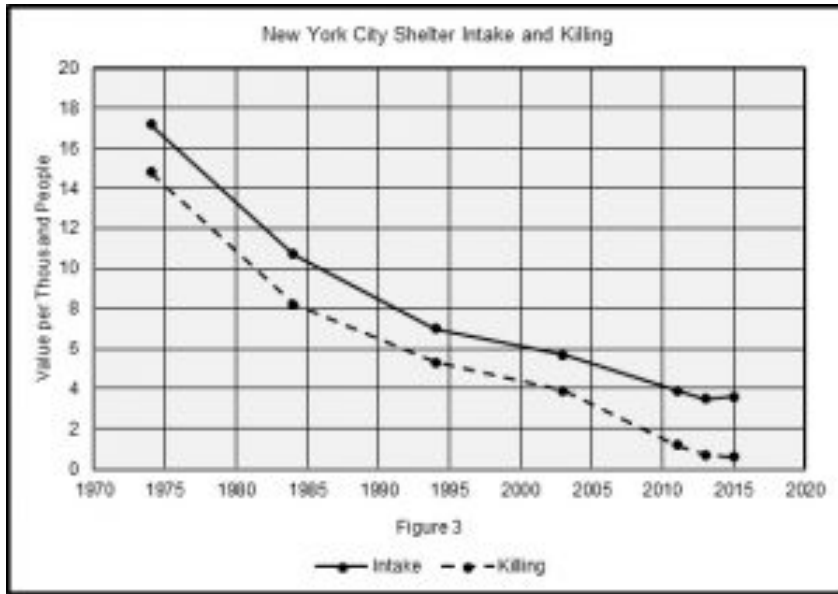

We have actual data from a couple of large shelter systems for the period from 1970 to 2000, and that data also shows a downward trend. Figure 2 shows data from a county in California.⁹⁷

A striking conclusion from this graph is that at least until 1997 (when the method of data collection changed) the reduction in shelter killing in this California county closely paralleled the reduction in shelter intake. This meant that, although the percentage of animals killed declined sharply,

the decline was due to fewer animals coming in the door, not more animals leaving alive.⁹⁸ As has been pointed out by Peter Marsh, this phenomenon was a common trend in shelters.⁹⁹

Actual data from the New York City shelter system from 1970 to 2000 also shows shelter intake declining sharply and in parallel with shelter killing. In New York City, though, the two lines in the graph begin to diverge in the early 2000s. For the first time, the number of live releases per thousand people was increasing.

What explains this pattern of live releases failing to increase from 1970 to 2000 even as shelter intake was declining? The explanation may be that the number of pets that could be easily obtained from friends, neighbors, and on the street had to decline to a certain level before shelter animals could compete for homes. As long as dogs and cats were freely available in the environment, people may have had little interest in adopting from a shelter. And shelters in the 19th and 20th centuries were ill-equipped to take advantage of a better climate for marketing their animals, since their operating procedures had been designed for taking in and killing large numbers of animals.

An alternative model for shelter operations existed in which healthy and treatable animals were not killed. This model, although it originated in the late 1800s, was never able to gain much traction during the years of pet overpopulation. Around 1970, at about the same time that shelter intake started to decline, this model slowly began to evolve from its very simple beginnings and gain in popularity. The next three Parts discuss the origin of this new operational model, which came to be known as No Kill, in the years from 1970 to 2000.

⁹⁷ Figure 2 is based on data supplied to the author by Andrew Rowan.

⁹⁸ It is possible that the composition of live releases may have changed somewhat. For example, there could have been an increase in adoptions or redemptions as the number of animals going to laboratories declined.

⁹⁹ Peter Marsh, *Replacing Myth with Math: Using Evidence-Based Programs to Eradicate Shelter Overpopulation* (Concord, NH: Town and Country Reprographics, 2010), 6–7, accessed April 16, 2017, http://www.shelteroverpopulation.org/SOS_Chapter-1.pdf.

Part IV: The No Kill Idea

Chapter 11: Evolving Attitudes Toward Homeless Pets

As shelter intake relative to human population fell in the period from 1970 to 2000, interest in new models of shelter operation grew. The way in which these new models developed was naturally affected by public attitudes toward shelter animals. Before looking at the evolution of new models, it is worth examining the evolution of human attitudes toward homeless pets.

The way the media treats homeless cats and dogs has changed notably over time. Newspapers in the post-Civil War years often took a dismissive attitude toward shelter killing and sometimes took a mocking attitude toward humane advocates who tried to protect homeless cats and dogs. For example, journalists belittled the Women's Branch of the Pennsylvania SPCA in 1870 for opening a humane shelter for impounded dogs.¹ By the early 1900s, though, newspapers were running occasional sympathetic stories about homeless pets.

In 1902, the *Boston Globe* featured such a story, describing how a homeless mixed breed dog who had become a police mascot had a narrow escape from the dog catcher.² And in the fall of 1905, the *Philadelphia Inquirer* reported that the mayor of Atlantic City had decided to close the city's pound until the following year because of public protests that the dogs were starved and mistreated.³ This story was reported in a straightforward manner, not with the jocular tone that was common in articles about dog pounds in the middle and late 1800s.

The sympathetic approach struck a chord with the public. One example was a story that started in March of 1913 in Boston, when a young woman found a four-month-old puppy shivering in a doorway on a cold day. The woman lived in an apartment where she could not keep a pet, so she took the puppy to the city shelter, which was run by the Animal Rescue League (ARL) of Boston. The ARL named the puppy "Susie." No owner appeared to claim her and she was scheduled to be killed. The woman who had found Susie and brought her to the shelter did not want that to happen, so she made an appeal to the *Boston Post*. The ARL agreed to delay Susie's killing to see if an adopter would come forward.

On March 31st, the *Boston Post* featured a prominent article about the puppy and her impending execution.⁴ The story included a photograph of Susie, who was a homely, nondescript little mutt described as having a friendly and playful nature. She was scheduled to be killed at noon the following day if no one came to adopt her. Susie made news again the next day when the *Boston Post* reported that "hundreds of men, women, and children" who had seen her story "wrote, telephoned, telegraphed, and called in person" wanting to adopt her.⁵ The successful applicant was Mrs. Estelle Tyler-Warner, a woman of "wealth and social standing." The newspaper printed a photograph of Mrs. Tyler-Warner posing with Susie before carrying her off to a new life.

Some of the change in attitude toward homeless dogs that had occurred by the early 1900s was probably due to the discovery of a post-exposure vaccine for rabies in the late 1800s. Free roaming dogs, particularly homeless, mixed-breed dogs, were seen as the primary vector for transmitting rabies to humans in the

¹ Mary Lovell, *Outline of the History of the Women's Pennsylvania Society for the Prevention of Cruelty to Animals: From Its Foundation April 14, 1869, to December 31, 1899* (Philadelphia: Women's Pennsylvania Society for the Prevention of Cruelty to Animals, 1900), 4.

² "But Spider Didn't Die," *Boston Globe*, July 30, 1902.

³ "Atlantic's Dog Pound Closed," *Philadelphia Inquirer*, October 21, 1905.

⁴ "Reprieve is Granted to Homeless Puppy," *Boston Post*, March 31, 1913.

⁵ "Hundreds Strive to Make Home for Susie," *Boston Post*, April 1, 1913.

1800s,⁶ and as the danger of death from rabies waned the status of mixed breed dogs increased. Animal welfare organizations began to make efforts to promote homeless dogs as pets. The San Francisco SPCA held a children's pet show in 1905, a concept that became widely promoted as part of humane education.⁷ The Women's Pennsylvania SPCA held a "Just Plain Dog Show" in 1915 with silver cups for prizes.⁸ Humane societies, SPCAs, and animal rescue leagues started to promote adoption of shelter pets and worked to change the bad image of mixed breeds.⁹ By the 1920s, the view that mixed breed dogs were inherently inferior had faded.

Another important factor in changing attitudes toward homeless pets may have been humane education. When the early SPCAs started their humane-education programs in the years after the Civil War, they used written materials and lectures to promote their message.¹⁰ Later, in the 1890s and early 1900s, humane education advocates used evolving forms of media to promote their message, although some educators were suspicious of the corrupting influence of popular media on children.¹¹ In the period from 1920 to 1970, formal humane education in many places relied on animal control officers or other humane workers or volunteers visiting schools and talking to children about kindness to animals.¹² This school outreach did not generally deal with controversial issues like the increasing use of factory-style conditions for raising meat animals, the ongoing cruelties of livestock transport and slaughter, and animal experimentation.

Although humane education advocates made some use of popular media in the 1920s and beyond, their influence was small compared to that of commercially produced animal stories. Sympathetic stories about animals, particularly dogs, became a fixture of films, radio, and eventually television in the 20th century. These stories often echoed the "animal autobiographies" that were central to humane education in the late 1800s,¹³ although the motivation for their production appears to have been more commercial than hortatory. Films and television programs about animals allowed children to imagine what it felt like to be an animal and may have helped children realize that animals are creatures with their own awareness and emotions.



Figure 35:
Sunnybrook Lad, the prototype of a hero collie in
Albert Payson Terhune's stories. Public domain.

⁶ See chapter 1.

⁷ Bernard Unti, "The Quality of Mercy: Organized Animal Protection in the United States, 1866–1930" (PhD diss., American University, 2002), 496–497.

⁸ "Plain Dogs to Compete," *Philadelphia Inquirer*, May 20, 1915.

⁹ Unti, "Quality of Mercy," 493.

¹⁰ See chapter 4.

¹¹ Janet Davis, *The Gospel of Kindness: Animal Welfare and the Making of Modern America* (New York: Oxford University Press, 2016), 60–61.

¹² Bernard Unti and Bill DeRosa, "Humane Education Past, Present, and Future," in *The State of the Animals II: 2003*, ed. Deborah Salem and Andrew Rowan (Washington, DC: Humane Society Press, 2003), 32–33.

¹³ See chapter 4.

A popular theme in both print and films following World War I was the hero dog.¹⁴ Albert Payson Terhune wrote stories during this time that drew on his experiences with collies he raised on his 40-acre estate in New Jersey. Terhune's collie stories might seem sentimental to some readers today, but they have considerable narrative force and are notable in their respect for the intelligence and character of dogs.



Figure 36:
Rin Tin Tin circa 1929. Public domain.

Silent films, which were popular from the late 1800s to the late 1920s, made a star of a dog named Rin Tin Tin. The real-life story of Rin Tin Tin was as remarkable as any of his movie roles. He was a German Shepherd who was born in 1918 in an area of active battle in France during World War I.¹⁵ An American soldier, Lee Duncan, found him and his mother and littermates in the remains of a bombed-out kennel when the puppies were a few days old. Substantial numbers of dogs were deployed by armies in World War I—an estimated 30,000 by the Germans and at least 20,000 by the Allies—and the kennel where Rin Tin Tin was found had probably been used to train German war dogs.¹⁶

Duncan kept two of the puppies, a male and a female, and found homes for the mother and the rest of the litter. He named his puppies Rin Tin Tin and Nanette after small dolls that were popular with the soldiers as good luck charms. When the war ended the future of

the puppies was uncertain. The majority of war dogs were killed, but Duncan wanted to bring the puppies home with him. At the last minute, he was able to obtain the needed paperwork, and all three of them boarded a ship for the United States.¹⁷

Rin Tin Tin appeared in 29 films, most of them silent films that have been lost.¹⁸ He died in 1932, but left many descendants (including one who starred in a Rin Tin Tin television series in the 1950s).¹⁹ Silent films offered an ideal vehicle for hero dog stories. One barrier that can prevent people from fully identifying with animals is their lack of speech. This barrier was overcome in novels such as *Black Beauty* by the device of having the animal tell his or her own story. In silent movies, no one could speak, and the hero dog communicated the same way the human actors did, by actions and facial expressions.²⁰ This served to equalize dog and man. Rin Tin Tin was an excellent silent film actor, with the ability to telegraph his emotions on screen and draw his viewers in.

¹⁴ Susan Jones, *Valuing Animals* (Baltimore: Johns Hopkins University Press, 2003), 116–118.

¹⁵ Susan Orlean, *Rin Tin Tin: The Life and the Legend* (2011; repr., New York: Simon & Schuster, 2012), 11, 28–29.

¹⁶ *Ibid.*, 21–22, 28.

¹⁷ *Ibid.*, 32–33.

¹⁸ *Ibid.*, 68, 96–97.

¹⁹ *Ibid.*, 4–5.

²⁰ *Ibid.*, 101.

Lassie, like Rin Tin Tin, was a hero dog who had a career in film and television. The first Lassie movie, adapted from Eric Knight's 1940 book *Lassie Come-Home*, was released in 1943 and was very successful.²¹ The message from the Lassie films was that any dog, even the family pet, could be a hero. Although the fictional Lassie was a female, the movie and television Lassies were played by a series of male dogs. The trainer of the original Lassie (a dog named Pal) felt that Pal had several qualities that drew audiences to the dog both on and off the stage, including an ability to perceive how people were feeling and a true actor's instinct to play to a crowd. Like Rin Tin Tin, he was able to engage the audience by his expressiveness. When MGM gathered 58 of its greatest stars for a group photograph in 1949, Pal was not only included but was front and center.²²



Figure 37:
Pal, the dog who played Lassie in the 1943 film Lassie Come Home. Public domain.

“Old Yeller” was another hero dog whose popularity in the media spanned multiple genres. His story was told first in Fred Gipson's eponymous 1956 novel,²³ and then made into a movie by Disney. Old Yeller was like Lassie in that he saved his family many times. Unlike Lassie, Rin Tin Tin, and Terhune's collies, though, Old Yeller was a mixed breed. In fact, the term “yellow dog” was a synonym for mongrel. Old Yeller was a talented working dog, which was more valuable than bloodlines in the mid-1800s frontier setting of the story. One interesting thing about this story is that, although Old Yeller is ultimately shot because he was bitten by a rabid wolf (while saving the family yet again), he is presented as a sympathetic victim of the dread disease rather than a propagator of it.

In addition to realistic films like *Old Yeller*, Disney made a series of animated films featuring talking animals. These films solved the language problem in a new way, by allowing animals to speak directly to each other and to the audience. Disney movies presented a wide variety of animals in a humanlike way, including wild animals. And whereas the hero dog genre featured only animals of exceptional ability and intelligence, Disney movies included typical, everyday animals.

The trope of the speaking animal was carried even further in Universal Studio's movie *Babe*, adapted from a 1983 novel and released in 1995. *Babe* was a typical realistic movie except that it featured a pig who could converse with other animals, although not with humans. The movie received both critical and popular acclaim.

Books, films, and television programs that presented sympathetic depictions of animals had several different relationships to reality. The novel *Black Beauty* was realistic in everything except the device that the book was narrated by a horse. The Terhune books told stories that were realistic and believable about dogs who were almost, but not quite, too good to be true. The Rin Tin Tin and Lassie movies and television shows featured real dogs but the stories they told about the dogs sometimes stepped over the line of a real

²¹ Ace Collins, *Lassie: A Dog's Life* (New York: Penguin, 1993), 14–22, 47.

²² *Ibid.*, 53.

²³ Fred Gipson, *Old Yeller* (1956; repr., New York: Harper Perennial Modern Classics, 2009).

dog's capabilities. The Disney animated films had an even more tenuous relationship to reality, but this allowed Disney films to deal with issues like hunting that might have been thought too brutal for a realistic film for small children.

One of the Disney movies—*Lady and the Tramp*, released in 1955—had special relevance to animal shelters. At the time the film was released, American Kennel Club registration of purebreds was on the way up,²⁴ but the male star of the movie was a mixed-breed dog. He was also homeless—a “tramp,” as unowned dogs were called in the 1800s and early 1900s.²⁵ In the animal autobiographies from the 1800s and the hero dog books and films from the 1900s, the animals existed to serve humans. *Black Beauty*, *Rin Tin Tin*, *Lassie*, and *Old Yeller* were all presented as admirable due to their devotion to their human masters and their willingness to sacrifice their own interests for those of humans. *Tramp's* life, as depicted in the film, contradicted the idea that homeless dogs and cats were miserable, helpless creatures and that shelters were doing them a favor by impounding and killing them. In fact, *Lady and the Tramp* presented shelter killing as an evil and undeserved fate that ended worthwhile lives.²⁶ By challenging the idea that dogs cannot live happy lives as strays, the film implicitly challenged the idea that that death is a kindness for a homeless animal.



Figure 38:
Cleveland Amory wrote popular stories about his rescued cat, Polar Bear.
Public domain.

Books in the post-World War II period featured many types of humanized animals. Cleveland Amory, the founder of the Fund for Animals (1967), and a successful novelist, reporter, commentator, and critic, wrote a popular series of stories about his rescued cat, Polar Bear. E.B. White, the legendary expert on English language style and a longtime contributor to the *New Yorker* magazine, wrote the novels *Charlotte's Web* and *Stuart Little*, which featured a pig, a spider, a rat, and a mouse among other creatures. *Stuart Little* is particularly interesting in that it presents the hero as simultaneously a human (the child of two humans) and a mouse, which is one of the most despised types of animal.

The genre of books and films that presented animals as comparable to humans, at least as to their ability to feel emotions, served as a counterweight to the scientific emphasis in the mid-1900s on condemning anthropomorphism. The post-World War II baby

boom generation was arguably exposed to more anthropomorphic animal stories, in more types of media, than any generation before it. *Stuart Little* was published in 1945, *Charlotte's Web* in 1952, and *Old Yeller* in 1956. Some of the most popular Disney movies about animals were from that period as well, including *Bambi* (1942), *Lady and the Tramp* (1955), *Old Yeller* (1957), and *101 Dalmatians* (1961). The original

²⁴ Martha Armstrong, Susan Tomasello, and Christyna Hunter, “From Pets to Companion Animals,” in *The State of the Animals: 2001*, ed. Deborah Salem and Andrew Rowan (Washington, DC: Humane Society Press, 2001), 75.

²⁵ Katherine Grier, *Pets in America: A History* (Chapel Hill: University of North Carolina Press, 2006), 213–214.

²⁶ Alan Beck's studies of stray dogs in Baltimore 15 years after *Lady and the Tramp* was released provided some evidence to back up the idea that the life of a stray dog was not as miserable as was generally thought. See chapter 8.

Lassie novel was published in 1940, and there were seven Lassie movies between 1943 and 1951, as well as the Lassie television series that started in 1954 and ran for 20 years.²⁷

Stephen Kellert, who was a professor of social ecology at Yale University, did research in the 1970s on attitudes of people in the United States toward animals, including wildlife.²⁸ He found that there were two common positive attitudes toward animals, which he called Humanistic (a love of individual animals, usually pets), and Moralistic (a concern with the ethical treatment of animals and opposition to animal exploitation).²⁹

At the time Kellert did his surveys in the 1970s, people expressing Humanistic and Moralistic attitudes toward animals were disproportionately young.³⁰ The Humanistic view was especially common in people age 18 to 25. Negative attitudes toward animals were more common in people over 45.³¹ In the mid-1970s people under age 25 were in the baby boom generation, which constituted a major demographic bulge. As the large number of baby boomers with Humanistic and Moralistic attitudes toward animals matured, it is possible that they retained those attitudes.

The increased incidence of pet sterilization in the 1970s may itself have had a part in a change of attitude by pet owners, because a sterilized pet is less likely to wander and may have better behavior within the home. The greater tendency of sterilized pets to stay at home and the decline in nuisance behaviors may have made people bond more closely with their pets. And as the number of homeless pets in the environment declined, people may have valued the remaining animals more. It was easy to place a low value on cats and dogs when there were strays everywhere and a puppy or kitten could be had for the asking.

Andrew Rowan has proposed several other factors that may have been at work in changed attitudes toward animal issues in general since 1950. These include a movement away from the “behaviorism” school of animal psychology to a greater appreciation for the cognitive abilities of animals, the migration of people away from farms where they had direct experience with the realities of meat production, the animal rights movement, and the increasing social status and political power of women, who show measurably higher support than men for animal protection.³²

The 1960s and 1970s also coincided with an increased concern about the environment and more attention to conservation. And increased pet food advertising may have helped create the perception that it was socially permissible to regard a pet as a valued family member.³³ All these factors may have helped influence people’s attitudes toward their pets and toward homeless dogs and cats.

²⁷ Collins, *Lassie*, 81–83, 173.

²⁸ Stephen Kellert, “American Attitudes Toward and Knowledge of Animals: An Update,” in *Advances in Animal Welfare Science*, ed. M. W. Fox and L. D. Mickley (Dord, NL: Martinus Nijhoff Publishers, 1984), 177, reprinted in *Humane Society Institute for Science and Policy: Societal Attitudes Toward Animals*, http://animalstudiesrepository.org/cgi/viewcontent.cgi?article=1000&context=acwp_sata; Stephen Kellert, “Human-Animal Interactions: A Review of American Attitudes to Wild and Domestic Animals in the Twentieth Century,” in *Animals and People Sharing the World*, ed. Andrew Rowan (Hanover, NH: University Press of New England, 1988), 138.

²⁹ Kellert, “American Attitudes Toward and Knowledge of Animals,” 179; Kellert, “Human-Animal Interactions,” 142–143.

³⁰ Kellert, “American Attitudes Toward and Knowledge of Animals,” 184, figure 4; Kellert, “Human-Animal Interaction,” 149–150.

³¹ Kellert, “American Attitudes Toward and Knowledge of Animals,” 184, figure 4; Kellert, “Human-Animal Interactions,” 150–151.

³² Andrew Rowan, “Animal Well-Being: Key Philosophical, Ethical, Political, and Public Issues Affecting Food Animal Agriculture,” in *Food Animal Well-Being, 1993 Conference Proceedings and Deliberations* (West Lafayette, IN: USDA/Purdue University, 1993), 28–30, accessed April 18, 2017, http://www.ansc.purdue.edu/wellbeing/FAWB1993/Food_Animal_Well_Being.html.

³³ Jones, *Valuing Animals*, 119–120.

Part IV: The No Kill Idea
Chapter 11: Evolving Attitudes Toward Homeless Pets

This change in attitude toward pets in the 20th century, and the public's increasing willingness to embrace homeless and mixed-breed cats and dogs as well as purebreds, may have been an important factor in encouraging new models for shelter operations that emphasized live releases. The next chapter looks at early adoption-promoting shelters, particularly a very successful one called Bide-A-Wee Home.

Chapter 12: Early No-Kill Sheltering

The great majority of animal shelters in the United States in the 1800s and 1900s killed most of the dogs and cats they took in, whether the shelters were public or private. There were a few private shelters that were exceptions to this rule. Bide-A-Wee Home in New York City was one of the most influential of those exceptions. Its operating plan was that only incurably ill animals would be killed.¹

Flora D'Auby Kibbe, née Jenkins, the founder of Bide-A-Wee, was born in Utica, New York after the Civil War.² Her father, who was the district attorney, died soon after her birth and her mother moved the family to New York City. Kibbe was impressed with a shelter she visited in France called Barrone d'Herpents Dog Refuge, which had a policy of finding adoptive homes for animals rather than killing them.³ In 1903, Kibbe founded the Bide-A-Wee Home as a private organization, modeling it on the French shelter. She formally incorporated the organization as the Bide-A-Wee Home Association in the state of New York on May 28, 1906.⁴ It was a membership corporation with seven original members, all women.⁵



Figure 39:
Flora D'Auby Kibbe

Kibbe had cared for strays in her home for several years before establishing Bide-A-Wee.⁶ She had Fox Terriers as pets, including a special favorite named Beau who was born in 1898 and lived for 18 years.⁷

Kibbe cited her love for Beau as her inspiration for founding Bide-A-Wee, and she sometimes took Beau with her when she went to visit the shelter.⁸ Bide-A-Wee was not intended as a sanctuary for permanent housing, a fact that was emphasized by its name, which means “stay a while” in the Scottish dialect. Although animals could stay as long as it took until they found a home, the expectation was that they would find homes.⁹

Bide-A-Wee took in sick, injured, and abandoned dogs and cats as well as owner surrenders, and it offered temporary boarding for dogs whose owners were on vacation.¹⁰ The shelter was designed to provide comfort to the canine and feline residents and emphasize their dignity and value.¹¹ Cats had group housing,

¹ William Swallow, *Quality of Mercy: History of the Humane Movement in the United States* (Boston: Mary Mitchell Humane Fund, 1963), 85–86.

² “Mrs. H. U. Kibbe Dies, Bide-A-Wee Founder,” *New York Times*, September 16, 1943.

³ Bide-A-Wee Family Album, 1903–2003, Newsletter Centennial Edition (New York: Bide-A-Wee Home Association, 2003), 4.

⁴ *Bide-A-Wee Family Album*, 4; NYS Department of State, Division of Corporations, Entity Information.

⁵ Bide-A-Wee Home Association, Certificate of Incorporation, State of New York (1906).

⁶ “Mrs. H.U. Kibbe Dies.”

⁷ *The Story of Bide-A-Wee: The Home for Friendless Animals* (New York: privately printed, 1924), 5–6, 11.

⁸ *Ibid.*, 5–8.

⁹ “Bide-A-Wee’s 85th Year: ‘Serving and Saving Since 1903,’” *Bide-A-Wee News*, Spring 1988, 7.

¹⁰ *Story of Bide-A-Wee*, 6, 9–10; “Streets Waifs Safe in Bide-A-Wee Home,” *New York Times*, July 25, 1920; “A Home Where the Despised ‘Yellow Dog’ is Welcome,” *New York Times*, March 18, 1906; “Bide-A-Wee Dogs Ordered Turned Out,” *New York Times*, June 18, 1909.

¹¹ *Story of Bide-A-Wee*, 4–8.

with indoor and outdoor areas for adult cats and a separate area for kittens.¹² Their diet was described as “plenty of milk and the finest cat meat.”¹³ Dogs apparently liked the Bide-A-Wee shelter, as there were stories of dogs who were placed in adoptive homes and then ran away and made their way back to the shelter.¹⁴ By 1907, Bide-A-Wee was operating a free emergency hospital for animals.¹⁵ There were isolation areas in the shelter for new arrivals and for dogs suffering from distemper, which was common in those years.¹⁶

Since Bide-A-Wee’s mission was to find homes for all of its healthy and treatable animals, adoptions were a priority. Kibbe used various adoption promotions, including one that invited people to stop by for a cup of tea and then take home a dog if they wished.¹⁷ Bide-A-Wee did not charge an adoption fee, but people had to show that they were financially able to care for a pet and agree to a home visit and follow-up calls.¹⁸ A small fee was charged for a collar, leash, and muzzle for dogs,¹⁹ to ensure that they would not be picked up by animal control for lack of compliance with city ordinances.

Bide-A-Wee’s adoption rate in 1907 and 1908 was roughly two out of every three animals taken in.²⁰ One reporter said that Bide-A-Wee saved almost 80% of its intake in 1912.²¹ Those save rates were impressive for the early 1900s, especially given the state of veterinary care for dogs and cats at the time and the fact that Bide-A-Wee took in many injured and ill animals.

Bide-A-Wee’s original shelter was located in Manhattan, where the ASPCA had its headquarters. At the time Bide-A-Wee was founded in 1903, the ASPCA had been running New York City’s public-shelter system by contract for almost 10 years. The ASPCA also had the responsibility for animal control in the city. Bide-A-Wee’s operating procedure of routinely treating animals for their illnesses and injuries rather than killing them meant that at any given time there were likely to be sick and injured animals at its shelter. In July of 1904, Bide-A-Wee’s shelter superintendent was summoned to answer an ASPCA complaint that the shelter contained dogs suffering from mange and other illnesses.²² The judge dismissed the charge for lack of evidence of a violation.

¹² *Ibid.*, 13–14.

¹³ *Ibid.*, 14.

¹⁴ “A Home Where the Despised ‘Yellow Dog’ is Welcome”; “Bide-A-Wee Home Homeless,” *New York Times*, April 3, 1911.

¹⁵ “Dreadful News for the Animals,” *New York Times*, May 6, 1907.

¹⁶ “A Home Where the Despised ‘Yellow Dog’ is Welcome.”

¹⁷ “A Dog with A Cup of Tea,” *New York Times*, March 7, 1912.

¹⁸ “A Home Where the Despised ‘Yellow Dog’ is Welcome.”

¹⁹ Story of Bide-A-Wee, 17–18.

²⁰ “Dreadful News;” “Bide-A-Wee Entertains,” *New York Times*, May 15, 1908.

²¹ Edwin Brewster, “A City of 4,000,000 Cats,” *McClure’s Magazine*, May 1912, 59.

²² “Bide-A-Wee Man Goes Free,” *New York Times*, July 3, 1904.



Figure 40:
Bide-A-Wee Home helped horses too, with sun hats and water troughs. "Sun Hats for Horses," 1907 photograph. Public domain.

That was only the beginning of Bide-A-Wee's problems with city officials. The shelter was relocated several times during its early years, sometimes because of a need for more space and sometimes because of neighbors' complaints about dogs barking.²³ The original Bide-A-Wee shelter was a small building located near Kibbe's home.²⁴ In the spring of 1907, Bide-A-Wee moved to 36 Lexington Avenue, which was a residential area at the time.²⁵ An article in the *New York Times* in July 1907 reported that neighbors of the shelter complained of "evil odors" and could not sleep due to barking dogs and howling cats.²⁶

In 1908 Bide-A-Wee took in an unusually large number of dogs to try to protect them from a city order that any dog who was not muzzled and leashed would be killed on sight.²⁷ To add to the problems that year, the Department of Health took action on the ongoing nuisance complaints against Bide-A-Wee, ordering the shelter to relocate.²⁸ Kibbe did not want to move the shelter out to some remote location, because she knew the importance of having a convenient in-town location to attract adopters.²⁹ She argued to city officials that the shelter did not have large numbers of dogs in residence most of the time, and mentioned that some of the most prominent people in New York were supporters of Bide-A-Wee.³⁰

The city relented enough to allow Bide-A-Wee to continue to operate the Lexington Avenue shelter as a receiving station, on the condition that the nuisances were abated.³¹ Kibbe agreed to transfer most of the dogs to an out-of-town location soon after they were admitted. She had to appear in court on a nuisance charge a month later, but by that time an investigation had cleared the shelter of any violation.³² The Chief Sanitary Inspector for the city stated that Bide-A-Wee was currently in compliance with all regulations, and blamed the complaints on conditions created by employees who had since been fired.³³

²³ Bide-A-Wee Family Album, 4.

²⁴ Ibid.

²⁵ Ibid.; "Dreadful News."

²⁶ "Complain of Bide-A-Wee," *New York Times*, July 17, 1907.

²⁷ "Animals' Friends Appeal," *New York Times*, September 28, 1908.

²⁸ "Bide-A-Wee Home Ordered to Move," *New York Times*, May 27, 1908.

²⁹ Ibid.

³⁰ Ibid.

³¹ "Respite for Dogs," *New York Times*, May 28, 1908.

³² "After Bide-A-Wee Home: Its Woman President Called to Court," *New York Times*, June 25, 1908.

³³ Ibid.

The following summer, with the shelter still located at 36 Lexington Avenue, neighbors' complaints reached a level that caused the city to take action to close the shelter without notice.³⁴ At eight o'clock in the morning on June 17, 1909, a Department of Health official appeared at the shelter and ordered it to turn out all the dogs.³⁵ ASPCA vans were standing by to pick up the animals. Since the ASPCA was killing over 90% of the animals it took in at the time,³⁶ letting the dogs go to the ASPCA likely would have meant death for most of them. The superintendent of Bide-A-Wee refused to release the dogs and the Department of Health official threatened to arrest him.³⁷ The superintendent called Kibbe, who told the official to proceed with the arrest if he insisted on it, because they were not going to turn over the dogs.

The official left to get a warrant, and Kibbe quickly arranged for two wagons to transport the dogs to Bide-A-Wee's property in Harrington Park, New Jersey.³⁸ Then she rushed to the Lexington Avenue shelter herself with her attorney in tow. The attorney managed to stall the police long enough for the wagons that Kibbe had ordered to arrive, but then another problem arose as an ASPCA veterinarian said that the wagons were not suitable for transporting the dogs. Kibbe dashed to ASPCA headquarters and talked to the president, who sent another representative, who finally allowed the Bide-A-Wee wagons to be loaded with the dogs and leave. The only animals remaining at the Lexington Avenue shelter were the cats and one dog, a mascot named Tiddlewinks. Kibbe resolved the situation by again getting permission to use the Lexington Avenue shelter as a receiving station where dogs could remain a short time before being taken to the Harrington Park property,³⁹ but this was far from an ideal solution.

In 1910, after Bide-A-Wee had been at the Lexington Avenue address for three years, a supporter offered a new home for the shelter at 244 East 65th Street.⁴⁰ The home was an old mansion with a large yard that was located away from residences. Bide-A-Wee had outgrown the Lexington Street location, and the new location allowed them to expand. The new property had room for a medical clinic with wards for different conditions. At the time of the move, Kibbe described Bide-A-Wee as being in better condition financially than it ever had been.⁴¹ She looked forward to a period of prosperity and growth, as they had a long-term lease on the new property.⁴²

In only a year though, Bide-A-Wee was uprooted again as a problem with its lease developed.⁴³ The animals were moved to temporary quarters while Kibbe looked for another permanent location.⁴⁴ On August 5, 1911, Bide-A-Wee obtained permission from the city's Department of Health to locate a "shelter for homeless animals" at 410 East 38th Street,⁴⁵ and the shelter moved into what would be its permanent Manhattan location. This location was far enough away from residences that the dogs would not bother anyone.⁴⁶ All the disruptions caused money troubles that Kibbe had to make up from her personal funds.⁴⁷

³⁴ "Bide-A-Wee Dogs Ordered Turned Out."

³⁵ Ibid.

³⁶ Stephen Zawistowski et al., "Population Dynamics, Overpopulation, and the Welfare of Companion Animals: New Insights on Old and New Data," *Journal of Applied Animal Welfare Science* 1, no. 3 (1998): 202, table 4, doi:10.1207/s15327604jaws0103_1.

³⁷ "Bide-A-Wee Dogs Ordered Turned Out."

³⁸ Ibid.

³⁹ Ibid.

⁴⁰ "Animal Rescuers Move Eastwards," *New York Times*, March 21, 1910.

⁴¹ Ibid.

⁴² "Bide-A-Wee Home Homeless."

⁴³ Ibid.

⁴⁴ Ibid.; "Bide-A-Wee Home Has Moved Again," *New York Times*, October 15, 1911.

⁴⁵ Department of Health, permit, City of New York (August 15, 1911).

⁴⁶ "Bide-A-Wee Home Has Moved Again."

⁴⁷ "Bide-A-Wee Head Is Ill," *New York Times*, October 5, 1912.

It was probably around this time that Bide-A-Wee commissioned an American sculptor, Laura Gardin Fraser, to create a medal for the Home.⁴⁸ The undated medal, which is a collector's item today, shows three dogs. The watchwords of the shelter—loyalty, devotion, forgiveness, and humor—are printed on the medal.⁴⁹ A shield with the same design was set above the door of the building at the East 38th Street location.⁵⁰ One of the dogs on the medal was modeled after Kibbe's dog Beau, and the other two were homeless dogs.⁵¹

Bide-A-Wee prospered after moving to its permanent location. In 1915, the organization was able to add a permanent country home for animals on a property in Wantagh, Long Island, about 25 miles east of Manhattan.⁵² The Wantagh property was large enough to allow sheltering of horses as well as dogs and cats.⁵³ This property was the location of Bide-A-Wee's Pet Memorial Park, a pet cemetery that had its first burial in 1916.⁵⁴



Figure 41:
The Bide-A-Wee Home medal, image licensed under CC BY-NC 4.0.

The Wantagh property in turn attracted the scrutiny of the ASPCA, and in 1916, the ASPCA filed charges against the property's manager, Isaac Parker.⁵⁵ The ASPCA alleged that dogs with mange were housed with healthy dogs and that the dogs were not given enough food.⁵⁶ The case went to trial, and several of the socially prominent women who supported Bide-A-Wee attended.⁵⁷ After the first day of the trial, Bide-A-Wee announced that the ASPCA's prosecution had motivated one of Bide-A-Wee's admirers to donate \$10,000 to the Home, and another to donate an ambulance.⁵⁸ On the second day of the trial, Bide-A-Wee presented evidence that the dogs on the Wantagh property were housed in clean quarters, fed on table scraps supplied by hotels such as the Waldorf-Astoria and the Vanderbilt, and did not have any contagious diseases.⁵⁹ The jury found Parker not guilty on the charges.⁶⁰

⁴⁸ David Alexander, "Honoring Bide-A-Wee: Medal Anything but a Dog," *Coin World*, November 4, 2011, <http://www.coinworld.com/news/us-coins/2011/11/honoring-bide-a-wee.all.html>.

⁴⁹ *Ibid.*

⁵⁰ *Story of Bide-A-Wee*, 8–9. The shield, in addition to the four watchwords that were on the medal, had the words "justice" and "compassion" on the lower rim.

⁵¹ *Ibid.*

⁵² *Bide-A-Wee Family Album*, 6.

⁵³ *Ibid.*, 9.

⁵⁴ *Ibid.*, 6.

⁵⁵ "Attacks Bide-A-Wee Home," *New York Times*, August 31, 1916.

⁵⁶ *Ibid.*; "After Bide-A-Wee Home: S.P.C.A. Starts a New Prosecution at Hempstead, L.I.," *New York Times*, November 23, 1916.

⁵⁷ "After Bide-A-Wee Home: S.P.C.A. Starts a New Prosecution at Hempstead, L.I."

⁵⁸ *Ibid.*

⁵⁹ "Clears Bide-A-Wee Home," *New York Times*, November 25, 1916.

⁶⁰ *Ibid.*

Bide-A-Wee's intake was 3,200 dogs and cats in 1906,⁶¹ about 4,500 in 1907,⁶² over 5,000 in 1908,⁶³ and about 7,000 in 1912.⁶⁴ In 1920, Bide-A-Wee reported that it had taken in almost 86,000 animals since it was founded in 1903.⁶⁵ Average weekly intake in 1924 was estimated at about 150 cats and at least 100 dogs.⁶⁶ From its founding in 1903 until at least into the 1920s, Bide-A-Wee appears to have accepted every animal brought to it, except for a brief period in 1917 while the Manhattan shelter was being rebuilt.⁶⁷

Although Bide-A-Wee may have been an open intake shelter in its early years in the sense that it did not turn animals away, in another sense it was not open intake because it did not have the duty to take in animals impounded by animal control. That duty was carried out by the ASPCA, under contract with the city. The ASPCA took in over 86,000 dogs and cats in 1904, which increased to about 237,000 in 1914, and increased again to over 303,000 in 1928.⁶⁸ In that time period and until after World War II, the ASPCA's overall live release rate was around 5% or less.⁶⁹ The number of animals Bide-A-Wee took in, although significant, was not enough to provide a solution for all homeless animals in the city.

The fact that the first 20 years of Bide-A-Wee's existence included frequent scrambles to avert disaster was not surprising, since it was operating on an unusual business model. One 1911 article described Bide-A-Wee as "leaping from crag to crag," like a mountain goat, to avoid disaster.⁷⁰ The constant drama of Bide-A-Wee being pursued by city authorities, the battles with the ASPCA, the money problems, and the high society fundraisers had an upside, though, which was that Bide-A-Wee was frequently in the news.

The newspapers were also happy to print the numerous human-interest stories that came out of Bide-A-Wee. Some were sad, like the story of the superintendent's stolen mascot who became a victim of the vivisectionists.⁷¹ Some were funny, like the story of the dog who became so fond of the attention he got for his injured paw that he continued to act the part of invalid even after the paw healed.⁷² Some were touching, like the story of Bide-A-Wee providing gifts for poor children in the neighborhood at Christmas.⁷³

Bide-A-Wee helped other shelters in emergency situations. Two sisters, Madeleine and Stella Mills, established a private shelter for dogs in the late 1890s in the Bronx.⁷⁴ For ten years they took in homeless dogs. Then Madeleine became ill, and Stella could not keep up with the kennel. Bide-A-Wee stepped in and took 70 dogs. Another shelter helped by Bide-A-Wee was the Be Kind to Animals Rest Farm, founded by James Briggs in Maryland in 1920.⁷⁵ It was a model establishment for many years, but was hit hard by the Depression and forced to close in 1932. Bide-A-Wee accepted 150 of the least adoptable dogs.⁷⁶

⁶¹ "Dreadful News."

⁶² "For the Johnston Bill," *New York Times*, February 29, 1908; "Bide-A-Wee Entertains."

⁶³ "Bridge for Bide-A-Wee Home," *New York Times*, May 19, 1909.

⁶⁴ Brewster, "A City of 4,000,000 Cats," 59.

⁶⁵ "Streets Waifs Safe in Bide-A-Wee Home."

⁶⁶ Story of Bide-A-Wee, 9.

⁶⁷ "Reconstruction at Bide-A-Wee Home," *New York Times*, January 27, 1917; *Story of Bide-A-Wee*, 10.

⁶⁸ Zawistowski et al., "Population Dynamics," 202, table 4.

⁶⁹ *Ibid.*

⁷⁰ "Bide-A-Wee Home Has Moved Again."

⁷¹ "Vivisectionists Got a Bide-A-Wee Pet," *New York Times*, May 29, 1910.

⁷² "A Home Where the Despised 'Yellow Dog' is Welcome."

⁷³ "Dog Xmas to the Children," *New York Times*, December 27, 1916.

⁷⁴ "Anybody Want a Dog?," *New York Times*, July 2, 1909.

⁷⁵ Anna Briggs, *For the Love of Animals: The Story of the National Humane Education Society* (n.p.: Potomac Publishing, 1990), 52. Anna Briggs, James' spouse, went on to found the National Humane Education Society in 1948.

⁷⁶ *Ibid.*, 70–71.

Bide-A-Wee continued to make progress under Kibbe's leadership, even during the Depression. She remained president of Bide-A-Wee until her death in 1943, following complications from a broken leg.⁷⁷ Her daughter Dorothea succeeded her as president and held that office for many years.⁷⁸ Bide-A-Wee still exists today, now known as Bideawee.⁷⁹

After World War II, in response to the growth of the human population of Long Island, Bide-A-Wee developed the Wantagh property from an overflow facility into a second shelter.⁸⁰ In the 1950s, Bide-A-Wee acquired a third property, 25 miles further out on Long Island from Wantagh, aided by donations from the Hofstra family.⁸¹ This property, 200 acres in Westhampton, had kennels and a cattery. An adoption center was built on the Westhampton property in 1966 with funds donated by author P.G. Wodehouse and his wife, and a second Pet Memorial Park was established at the site soon after.⁸² The Bide-A-Wee Pet Memorial Parks are the final resting place of some famous dogs, including president Nixon's dog Checkers and Sarge, the K-9 Corps mascot in World War II.⁸³

As Bide-A-Wee has continued to expand and develop its three properties, it has also continued its emphasis on medical treatment, with veterinary clinics open to the public at all three locations.⁸⁴ And it continues the policy, which is built into its charter, of never killing an animal unless the animal is incurably ill.⁸⁵

Another early shelter that aspired to find new homes for its healthy and treatable animals was the Ellen M. Gifford Sheltering Home, founded in 1884 in Boston by Ellen Gifford and Captain Nathan Appleton.⁸⁶ Gifford provided the funds to found the Home and Appleton donated the land for the shelter.⁸⁷ Gifford and Appleton were reportedly inspired by animal shelters in Paris and London.⁸⁸ Gifford stated that she wanted to take in "the waifs, the strays, the sick, the abused" and any "starved or ill-treated animal."⁸⁹

The Gifford Home was turned over to the Massachusetts SPCA to manage during its first two years of existence.⁹⁰ The superintendent of the shelter, Albert Perkins, said that homes were found for some animals during that two-year period and others were killed. Gifford felt that the SPCA was not giving the home enough attention, so she took over management of it in 1886 and appointed a woman from Boston, Mrs. Cushing, to oversee the shelter. At first, the Home had taken in both cats and dogs, but it became a dog only shelter in 1886 because, as Perkins explained, they did not have enough land to accommodate the rapid multiplication rate of cats.

⁷⁷ "Mrs. H. U. Kibbe Dies."

⁷⁸ Swallow, *Quality of Mercy*, 86.

⁷⁹ Home page, *Bideawee*, accessed April 19, 2017, <https://www.bideawee.org/>.

⁸⁰ Bide-A-Wee Family Album, 8.

⁸¹ *Ibid.*

⁸² *Ibid.*, 10.

⁸³ "Bide-A-Wee's 85th Year," 7.

⁸⁴ *Ibid.*, 10.

⁸⁵ Kathleen Young, "Responsibilities of Shelters," panel discussion in *Overpopulation of Cats and Dogs: Causes, Effects, and Prevention*, ed. Marjorie Anchel (New York: Fordham University Press, 1990), 107.

⁸⁶ Helen Winslow, *Concerning Cats: My Own and Some Others* (Boston: Lothrop, Lee & Shepard, 1900), 190–191; "About Us," *Gifford Cat Shelter*, accessed April 20, 2017, <http://www.giffordcatshelter.org/about-us/>.

⁸⁷ Winslow, *Concerning Cats*, 189–191.

⁸⁸ "A Canine Charity," *Boston Daily Globe*, June 4, 1886; Winslow, *Concerning Cats*, 189–190.

⁸⁹ Winslow, *Concerning Cats*, 191.

⁹⁰ "A Canine Charity."

After Gifford took back control of the shelter, the policy was to kill only animals who were sick and incurable.⁹¹ Cushing stated that the Gifford Home was able to maintain its policy of not killing healthy or treatable dogs because there were “very few curs left” in Boston. She cited Boston’s licensing ordinance, the work of the city’s dog catchers, and the popularity of imported purebred dogs for the small number of free roaming mixed-breed dogs in Boston. She said that the shelter was able to quickly find homes for the dogs they received. They took in only homeless animals, not animals surrendered by their owners.⁹²

By 1888, the Gifford Home was again taking in cats.⁹³ It had separate areas for dogs and cats, with yards for each, and shelves with straw bedding for the cats.⁹⁴ It took in 142 dogs and 116 cats in 1888, with save rates roughly comparable to Bide-A-Wee.⁹⁵ It emphasized adoptions, and in one case adopted out six cats to a man who had a large granary and needed cats to keep the mice in check.⁹⁶ The superintendent investigated potential adopters to ensure that they could provide a good home. Eventually, the Gifford Home transitioned to caring for cats only, and changed its name to the Gifford Cat Shelter.⁹⁷ It still exists today.

Another type of organization in the late 1800s that did not kill healthy or treatable animals was the horse sanctuary. The Home of Rest for Horses, founded by Ann Lindo in England in 1886, was an influential model.⁹⁸ Lindo wanted to provide a place where working horses who were injured or in poor condition could be rehabilitated and then return to their jobs.⁹⁹ The Ryerss Infirmary for Dumb Animals, located near Philadelphia, was an early horse sanctuary in the United States.¹⁰⁰ It was incorporated in 1888 and received its first horse—“old, blind, and weak”—in 1889.¹⁰¹ It housed horses that needed a permanent retirement home as well as those who just needed a rest before returning to work.¹⁰² The sanctuary still exists today and is known as the Ryerss Farm for Aged Equines.¹⁰³ The Red Acre Farm, another early horse sanctuary, was established in 1903 in Stow, Massachusetts.¹⁰⁴

The term “No Kill” was not used for shelters in the late 1800s and early and mid-1900s. The term “Home” was often used for shelters that sought to treat animals kindly, but apparently there were too few shelters that had non-killing policies before the 1970s to warrant their own descriptive term. Bide-A-Wee appears to have operated much like a modern No Kill shelter in its use of promotions and community outreach to find homes for animals that other shelters of the day would have considered unadoptable. Its operations in the early 1900s were surprisingly modern, so much so that they would not be replicated on a similar scale for decades to come.

⁹¹ Ibid.

⁹² Ibid.; Winslow, *Concerning Cats*, 192.

⁹³ “Sheltering Home for Animals,” *Boston Post*, April 29, 1889.

⁹⁴ Winslow, *Concerning Cats*, 192–193.

⁹⁵ “Sheltering Home for Animals.”

⁹⁶ Winslow, *Concerning Cats*, 192.

⁹⁷ “Our History,” *Gifford Cat Shelter*, accessed April 20, 2017, <http://www.giffordcatshelter.org/about-us/our-history/>.

⁹⁸ Frederic Haskin, “Homes for Animals,” *Washington Herald*, May 14, 1909; “The Home of Rest for Horses, Founded 10th May 1886,” *The Horse Trust*, accessed April 20, 2017, <http://www.horsetrust.org.uk/history/yesterday/home-of-rest-for-horses-1886/>. This sanctuary was renamed “The Horse Trust” in 2006. “After 120 Years the Horse Trust is Born,” *The Horse Trust*, accessed April 20, 2017, <http://www.horsetrust.org.uk/history/today/welcome-to-the-horse-trust/>.

⁹⁹ “The Home of Rest for Horses.”

¹⁰⁰ Haskin, “Homes for Animals”; “The History of Ryerss Farm,” *Ryerss Farm for Aged Equines*, accessed April 20, 2017, http://ryerssfarm.org/?page_id=1374.

¹⁰¹ “The History of Ryerss Farm.”

¹⁰² Haskin, “Homes for Animals.”

¹⁰³ “The History of Ryerss Farm.”

¹⁰⁴ “Red Acre Farm: The First Hundred Years,” *Red Acre Foundation*, accessed April 20, 2017, <http://redacrefoundation.org/history.htm>.

Chapter 13: Using Marketing to Save Lives

As discussed in the previous chapter, shelters that do not kill healthy or treatable animals have been around since the late 1800s in the United States. It was not until the 1970s, though, that “No Kill” became a generally recognized label for such shelters. The term “no kill” was used in the 1950s and 1960s to refer to the conservation practice of catch-and-release fishing,¹ and it is possible that the term migrated to sheltering from that context.² By the mid-1970s, several shelters called themselves “no kill.”³ Guy Hodge with the Humane Society of the United States estimated in 1974 that there were 12 to 15 shelters in the country that had policies not to destroy animals.⁴

No Kill shelters in the 1970s were private shelters that could control their intake. They did not have contracts with cities or counties that required them to take in all the animals impounded by animal control and all the animals surrendered by their owners. The ability to control intake was critical to the success of the early No Kill private shelters, since they could simply stop taking in animals when they had reached capacity.

Running a successful No Kill shelter in those days required considerable attention to balancing intake with adoption. No Kill private shelters used adoption instead of killing to get animals out of the shelter, and this required them to think about making their cats and dogs attractive to the public—in other words, marketing. One shelter in particular became known in the period from 1970 to 2000 for the very high number of adoptions it was able to achieve by using marketing methods. That shelter, the North Shore Animal League, may have been the first to call itself No Kill.⁵ Its success at getting animals out the door alive drew wide attention to the No Kill concept.

North Shore had its start as the North Shore Animal League and Dog Protective Association, granted incorporation on May 1, 1944, in Nassau County on Long Island, not far from New York City.⁶ North Shore was established as a membership corporation by eight people, all residents of Great Neck.⁷ The Certificate of Incorporation set forth the purposes of the organization, including “to act as a dog protective association in the protection, care, and disposition of dogs, lost, strayed, homeless or otherwise” and “to maintain a shelter house or houses for dogs and other animals” The founders started with just a garage and a few dog runs.⁸

¹ The National Park Service started a “Fishing for Fun” program in 1954 on an experimental basis to promote conservation by catch-and-release fishing, and in 1961 referred to “no-kill restrictions” under the program. “Anglers Fish for Fun in National Parks,” press release, *National Park Service*, June 11, 1961. “No Kill” became a common term for catch-and-release fishing.

² In the mid-1960s a Bakersfield, California, newspaper article reported that the local shelter had a “no-kill policy.” It is not clear if the shelter itself used the term “no kill” for its policy or if the reporter came up with the term. “No-Kill Rule Kept at Shelter,” *Bakersfield Californian*, August 20, 1965. The New York Times once analogized no-kill animal sanctuaries to no-kill rivers. “Humanities: Animal Welfare,” *New York Times Magazine*, June 4, 1995.

³ See, e.g., Tom Hennessy, “Finder of Felines at Tree House,” *Pasadena Star-News*, March 8, 1977; Sandy Riemer, “Local Save-A-Pet Warns of Ad Package,” *Daily Herald Suburban Chicago*, January 17, 1980.

⁴ William Mathewson, “With Right Tactics, It’s Easy to Market a Three-Legged Cat,” *Wall Street Journal*, March 6, 1975.

⁵ Mike Arms, email messages to author, February 17, 2015 and August 11, 2016.

⁶ New York State, Certificate of Incorporation (filed May 1, 1944).

⁷ The names of the founders as listed on the 1944 Certificate of Incorporation were J. G. William Greeff, Meyer Berliner, Alice Swanson, Anne Saunders, Estella R. Steiner, Ralph Fleidner, Mary Gray, and Marion Sanders.

⁸ “North Shore Animal League America—Our Beginnings,” *North Shore Animal League America*, accessed April 21, 2017, <http://www.animalleague.org/about-us/who-we-are/history/the-beginnings.html>.



Figure 42:
The town hall of North Hempstead is on the National Register of Historic Places. Photograph by Jim Henderson, licensed under CCO 1.0. Public domain.

Little information appears to have survived about the earliest years of North Shore. Journalist Merritt Clifton has reported that Marianne H. Sanders was the principal founder and that she formed the organization for the purpose of bidding on the animal control contract for the Town of North Hempstead.⁹ Clifton noted that Sanders had a goal of saving all healthy dogs who came into the organization's shelter.¹⁰ This information was based on interviews and some surviving documentation from North Shore's early days.¹¹ The eight founders who signed the 1944 incorporation certificate included a "Marion Sanders." "Marian H. Sanders" signed a certificate that North Shore

filed with the state in 1951.¹²

Bideawee,¹³ which had a policy of not killing healthy or treatable animals, had a shelter in Nassau County only about 20 miles from North Shore's headquarters, and Bideawee's main shelter in Manhattan was also not far from Great Neck. Bideawee's founder and president, Flora Kibbe, died on September 15, 1943, just a few months before North Shore's founders applied for incorporation in April 1944.¹⁴ The founders of North Shore probably knew about Bideawee, and it is an interesting question whether Kibbe's work was an inspiration for their goal to minimize shelter killing.¹⁵

North Shore was reportedly doing canine animal control for several villages in the Great Neck area by the 1950s, but began to give up animal control contracts in the 1960s, as population growth in the area burdened their efforts to save all adoptable dogs.¹⁶ By 1969, the organization was struggling financially and its future was in doubt.¹⁷ In this crisis, the North Shore board invited two of its financial supporters, Elisabeth ("Babette") and Alexander ("Alex") Lewyt, a wealthy couple who lived in the area, to a meeting to discuss the situation.¹⁸

⁹ Merritt Clifton, "Who Invented No Kill?," *Animal People*, September 2005, accessed September 10, 2014, <http://www.animalpeoplenews.org/05/9/whoinventedNoKill9.05.htm>.

¹⁰ *Ibid.*

¹¹ Merritt Clifton, email messages to author, February 15–16, 2015.

¹² New York State, Certificate of Incorporation; New York State, Certificate of Report of Existence (filed April 30, 1951).

¹³ See chapter 12.

¹⁴ "Mrs. H.U. Kibbe Dies, Bide-A-Wee Founder," *New York Times*, September 16, 1943; New York State, Certificate of Incorporation.

¹⁵ Clifton has written about this possibility. Merritt Clifton, "Babette Lewyt, Rescuer Who Rescued the North Shore Animal League," *Animal People*, January-February 2013; Merritt Clifton, "Anna Briggs, 101, Lived an Animal Rights Lifestyle Before There Was a Movement," *Animal People*, April 2011.

¹⁶ Clifton, "Babette Lewyt."

¹⁷ Audrey Allen, "This Very Special Dog Needs a Home," *Family Weekly*, March 18, 1973.

¹⁸ John Rendel, "Modern Merchandising Format Makes Animal Shelter Success," *New York Times*, May 14, 1970.

Babette Lewyt was born in France in 1913.¹⁹ She emigrated to the United States in 1936 and married Alex in 1953.²⁰ She was interested in animal welfare and was active with several humane organizations in the 1960s,²¹ and it was at her urging that Alex agreed to attend the North Shore board meeting.²² Alex, who was born in 1908 in New York City, was the son of immigrants from Austria.²³ He was a high school dropout who took over his father's modest factory and won government contracts during World War II.²⁴ He was given the French Legion of Honor for supplying equipment to Allied forces during the war.²⁵ After the war, he invented a new type of vacuum cleaner and marketed it very successfully.²⁶

The Lewyts promised at the North Shore board meeting in 1969 that they would raise \$3,000.00 for the shelter and recruit 1,000 contributors.²⁷ Their campaign got off to a good start when Perry Como, who lived in their neighborhood, agreed to serve as honorary chairperson.²⁸ The Lewyts compiled a list of 24,000 people who had bought dog licenses in Long Island and added the names of 4,000 potential large donors.²⁹ Harold Mertz, who had founded Publishers Clearing House in Port Washington in 1953, contributed half the cost of the campaign and drafted a letter for a direct mail appeal.³⁰ The letter, signed by Perry Como, was sent out in September of 1969.³¹ It contained a photograph of a puppy and a kitten with the text: "Would you give a dollar—just \$1.00—TO SAVE THEIR LIVES?"³² The campaign far exceeded its goals, and in six weeks, North Shore had donations of \$11,000 from 3,120 new donors.³³

By that time, the Lewyts were "hooked," as Babette put it.³⁴ They agreed to take over management of North Shore. The organization shortened its name in November of 1969 to North Shore Animal League, symbolizing a new era in its existence.³⁵ Babette became the chairman of the board,³⁶ and in the summer of 1970, Alex became the president of North Shore.³⁷ Their operating principle was to save all the healthy and treatable animals who came into the shelter.³⁸ In order to learn about animal sheltering, Alex visited 22

¹⁹ "Elizabeth Lewyt," *New York Times*, Jan. 15, 2013.

²⁰ *Ibid.*

²¹ Mathewson, "With Right Tactics."

²² Allen, "This Very Special Dog"; Walter Fletcher, "Dog's Best Friend a Master Salesman," *New York Times*, April 11, 1971.

²³ George Vecsey, "A Supersalesman Turns from Vacuum Cleaners to Homeless Pets," *New York Times*, Feb. 19, 1976; Sarah Lyall, "Alexander M. Lewyt Dead at 79; Invented Lewyt Vacuum Cleaner," *New York Times*, Mar. 21, 1988.

²⁴ Vecsey, "Supersalesman."

²⁵ *Ibid.*; Lyall, "Alexander M. Lewyt Dead at 79."

²⁶ Vecsey, "Supersalesman."

²⁷ Rendel, "Modern Merchandising Format."

²⁸ Mathewson, "With Right Tactics."

²⁹ Rendel, "Modern Merchandising Format."

³⁰ Linda Saslow, "It's Sweepstakes Time, and It's a Frenzy," *New York Times*, January 20, 1991; Rendel, "Modern Merchandising Format"; Mathewson, "With Right Tactics."

³¹ Mathewson, "With Right Tactics."

³² *Ibid.*

³³ Fletcher, "Dog's Best Friend"; Rendel, "Modern Merchandising Format." In addition to the direct-mail appeal, the campaign included thousands of posters, a Pet of the Week column, and 650,000 leaflets in bills mailed by a Long Island electric company. Rendel, "Modern Merchandising Format."

³⁴ Matthew Hickerson, "Aid from the Lewyts," *New York Times*, July 28, 1991.

³⁵ New York State, Certificate of Change of Name of North Shore Animal League and Dog Protective Association, Inc., to North Shore Animal League, Inc. (filed November 6, 1969). North Shore changed its name again, to North Shore Animal League America, Inc., on June 8, 2000. State of New York, Certificate of Amendment of the Certificate of Incorporation of North Shore Animal League, Inc (filed June 8, 2000).

³⁶ "Elizabeth Lewyt."

³⁷ Fletcher, "Dog's Best Friend."

³⁸ Vecsey, "Supersalesman."

shelters around the country.³⁹ In September 1970, the American Humane Association gave North Shore a plaque “[i]n appreciation for significant contributions to the humane cause.”⁴⁰

The Lewyts instituted several operational procedures at North Shore that have become common in shelters today but were unusual at the time. One example was preventive medical care for shelter animals. Every animal was vaccinated on intake unless it had received vaccinations in the preceding six months.⁴¹ North Shore also quarantined puppies and kittens on intake, a health practice that many traditional shelters did not follow.⁴²

The most influential of North Shore’s innovations in the 1970s had to do with management philosophy, including the use of marketing. An article in the *Wall Street Journal* in 1975 described Alex as running North Shore as if it were a large corporation, paying attention to receivables and inventories.⁴³ In a 1976 interview, Alex emphasized that his role was to move animals into homes.⁴⁴ If an animal was not adopted within a few weeks, they would try to determine the cause, and take steps to make the animal more attractive to adopters.

North Shore’s shelter, at that time, was a one-story house in Port Washington.⁴⁵ It had room for only 15 adult dogs, 12 puppies, and 12 cats or kittens.⁴⁶ Adoption numbers increased rapidly despite the small space, going from 127 in 1969 to about 4,200 in 1976.⁴⁷ Alex believed the answer to shelter killing was better adoption methods, not more shelter space.⁴⁸ He believed that it was more efficient to move animals quickly than to build extra space to hold animals longer.⁴⁹

Extended hours were an important part of the emphasis on marketing. One of the first things the Lewyts did was to arrange to have the shelter open every day of the week.⁵⁰ Many shelters in the 1970s had very limited hours, and often no hours during the evenings and weekends when people could visit the shelter as a family to pick out a pet. North Shore itself, before the Lewyts took over, was open only 10 hours per week and had only one paid employee.⁵¹ The Lewyts’ strategy of longer hours paid off, and the shelter had 10,000 visitors in 1970.⁵²

There was a widespread belief in traditional animal sheltering that advertising or offering any other type of incentive to adopt was bad because incentives would lead people to adopt on impulse or for the wrong reasons.⁵³ The Lewyts rejected this thinking, and made it a practice to use both promotions and incentives. In 1974, North Shore had an advertising budget of \$50,000.00.⁵⁴ Reaching out to the public was certainly

³⁹ Fletcher, “Dog’s Best Friend.”

⁴⁰ *Ibid.*

⁴¹ Fletcher, “Dog’s Best Friend”; Allen, “This Very Special Dog.”

⁴² Fletcher, “Dog’s Best Friend.”

⁴³ Mathewson, “With Right Tactics.”

⁴⁴ Vecsey, “Supersalesman.”

⁴⁵ Arms, email messages.

⁴⁶ Mathewson, “With Right Tactics.”

⁴⁷ Walter Fletcher, “City Dog Gives Rural Cousins Lesson,” *New York Times*, December 26, 1971; Vecsey, “Supersalesman.”

⁴⁸ Vecsey, “Supersalesman.”

⁴⁹ Allen, “This Very Special Dog.”

⁵⁰ Fletcher, “Dog’s Best Friend.”

⁵¹ Mathewson, “With Right Tactics.”

⁵² Fletcher, “Dog’s Best Friend.”

⁵³ Merritt Clifton, “Cutting Euthanasia Rates and Choking Puppy Mills: The Controversial Case for the North Shore Animal League’s Unconventional Methods,” *Animal People*, March 1993; Cornelia Lewine, “Before Abandoning and Adopting Pets,” letter to the editor, *New York Times*, August 25, 1991.

⁵⁴ Mathewson, “With Right Tactics.”

effective for fundraising, and the number of North Shore contributors went from 13,000 in the spring of 1971 to 100,000 in 1975.⁵⁵

By the mid-1970s, North Shore had a staff of 25 people, including eight full-time employees.⁵⁶ The adoption program was placing animals so quickly that Babette would set out almost every day in the North Shore “Love-A-Pet” van to drive around to other shelters on Long Island and bail out animals who were scheduled to be killed.⁵⁷ She reportedly rescued 3,000 dogs in this manner in 1980 alone.⁵⁸ Alex was frequently at the shelter.⁵⁹ Babette told a reporter in 1980 that working in the shelter was “all we want to do.”⁶⁰

In addition to pulling animals from other shelters, North Shore sometimes took in owner surrenders. A person who wanted to surrender a pet was asked to answer questions about the pet so that the shelter had background information on the animal.⁶¹ North Shore started programs in the early 1970s to help keep pets in their homes, including classes in dog training, a 24-hour lost pet hotline, and advice on animal care.⁶²

North Shore used marketing to place handicapped animals that most shelters of the time would have considered unadoptable. In a 1971 interview, Alex mentioned that North Shore had placed a blind German Shepherd and a deaf Dalmatian named La Veda.⁶³ In 1973, an advertisement for another deaf Dalmatian, Sasha, resulted in 30 families contacting the shelter wanting to adopt her.⁶⁴ Some animals who were not handicapped were hard to adopt for other reasons, as with one cat who had a hairless tail. Alex told a reporter that they would present the hairless tail as a feature and find the cat a home.⁶⁵ They used positive advertising for less than perfect animals, stressing their good points rather than trying to create pity for them.⁶⁶ North Shore used volunteer professional photographers to take pictures of animals for Pet-of-the-Week features that ran in local newspapers.⁶⁷ In a case where even North Shore’s adoption promotions could not find a home for an elderly dog with health issues, the dog became a mascot at the shelter.⁶⁸

Although North Shore’s goal was to move animals into homes, they had a screening process, and in the 1970s, they reportedly turned down 20% to 30% of people who applied to adopt.⁶⁹ In a 1975 interview, the North Shore kennel manager stated that they judged their success by their return percentage.⁷⁰ If an adoption failed, they tried to determine the cause, and used that information to make a better placement for that animal the next time. For example, one large dog who was returned because of reactive barking eventually found a permanent home in the suburbs in a quiet environment with fewer triggers.⁷¹ North Shore followed up adoptions with telephone calls to see how the animals were doing, and asked people to return

⁵⁵ Fletcher, “Dog’s Best Friend”; Mathewson, “With Right Tactics.”

⁵⁶ Mathewson, “With Right Tactics.”

⁵⁷ “Elizabeth Lewyt”; Arms, email messages.

⁵⁸ Associated Press, “Woman Saves Abandoned Pets,” *Farmington Daily Times*, December 24, 1980.

⁵⁹ Arms, email messages.

⁶⁰ Associated Press, “Woman Saves Abandoned Pets.”

⁶¹ Allen, “This Very Special Dog”; Fletcher, “Dog’s Best Friend.”

⁶² Allen, “This Very Special Dog.”

⁶³ Fletcher, “City Dog.”

⁶⁴ Allen, “This Very Special Dog.”

⁶⁵ Mathewson, “With Right Tactics.”

⁶⁶ Ibid.

⁶⁷ Allen, “This Very Special Dog.”

⁶⁸ Ibid.

⁶⁹ Arms, email messages; Vecsey, “Supersalesman”; Allen, “This Very Special Dog”; Mathewson, “With Right Tactics”; Fletcher, “Dog’s Best Friend.”

⁷⁰ Mathewson, “With Right Tactics.”

⁷¹ Allen, “This Very Special Dog.”

the pet if things were not going well.⁷² The return rate for adopted pets was about 15% to 20% in the 1970s, down from 25% when the Lewyts took over.⁷³ By 1993, North Shore's rate of animals returned after adoption was reported as less than 4%.⁷⁴

The procedure that North Shore used to evaluate adopters was considered unusual at the time. It was common for traditional shelters in the 1970s and for many years thereafter to have rigid adoption criteria.⁷⁵ They might require, for example, that anyone adopting a dog had to have a fenced yard, or that someone had to be home during the day. They might have a blanket rule that families with young children could not adopt pets. They might have a minimum income requirement. Adopters at traditional shelters were typically asked to fill out a written application, and if any of the answers were "wrong" the adopter was denied. North Shore rejected this inflexible system in favor of a more informal approach that centered on adoption counselors talking to prospective adopters and observing how they interacted with pets.⁷⁶ Today, a similar approach known as Open Adoption has gained wide acceptance in the shelter industry.⁷⁷

The *New York Times* featured a North Shore "adoption matchmaker" in an article in 1986.⁷⁸ The matchmaker, Paul Berman, used conversations with prospective adopters to match them with a suitable pet. North Shore did have general guidelines for adopters, such as no adoptions of young animals to older people, but the rules were flexible and Berman not infrequently broke them. If he felt that older adopters were in good health, he would adopt a puppy or kitten to them. He questioned people about allergies, paid attention to how they had treated their previous pets, and was careful to match pets to the entire family, including young children. Berman's specialty was placing adult dogs, and he could usually place 50 to 60 of them on a Sunday.

The Lewyts hired staff to run the shelter, but they remained involved with North Shore until their deaths.⁷⁹ Alex died in 1988, at the age of 79 years.⁸⁰ Babette died on December 9, 2012, not long before her 100th birthday.⁸¹ Her family asked that people wanting to honor her memory adopt a pet.⁸²

Perhaps the most notable of the hires that the Lewyts made at North Shore was Mike Arms, who started with the organization in 1977.⁸³ North Shore greatly increased its adoptions under the Lewyts, but with Arms, the shelter raised its adoption totals to new heights. North Shore adopted out 6,330 dogs and cats in 1977, the year Arms joined the organization.⁸⁴ By 1990, that number was up to 42,150.⁸⁵ About 1,200 families per week came through the facility during the busiest years while Arms was there.⁸⁶

⁷² Ibid.; Mathewson, "With Right Tactics"; Vecsey, "Supersalesman."

⁷³ Mathewson, "With Right Tactics."

⁷⁴ Clifton, "Cutting Euthanasia Rates and Choking Puppy Mills."

⁷⁵ *1999 Adoption Forum* (Englewood, CO: American Humane Association, 1999), 6.

⁷⁶ Mathewson, "With Right Tactics."

⁷⁷ See chapter 20.

⁷⁸ "Our Towns; An Adoption Matchmaker for Pets," *New York Times*, July 22, 1986.

⁷⁹ "Elizabeth Lewyt"; Lyall, "Alexander M. Lewyt Dead."

⁸⁰ Lyall, "Alexander M. Lewyt Dead."

⁸¹ "Elizabeth Lewyt."

⁸² Ibid.

⁸³ Arms, email messages.

⁸⁴ Matthew Hickerson, "Love for Animals Runs Deep on L.I.," *New York Times*, July 28, 1991.

⁸⁵ Ibid.

⁸⁶ Arms, email messages.

Arms continued the approach of using marketing as the key to increased adoptions.⁸⁷ His previous experience had been in animal sheltering with the ASPCA,⁸⁸ but he turned out to be a highly effective marketer. One of his ideas was to take advantage of the market opportunity presented by holiday adoptions. Traditional municipal animal shelters in the 1970s often prohibited holiday adoptions and adoption of pets as gifts. Their directors thought that people were too busy on holidays, especially Christmas, to bring a new animal into the home. And they thought that black cats should not be adopted out around Halloween.



Figure 43:
Many shelters in the 1900s refused to adopt out black cats around Halloween because of their association with witchcraft. Public domain.

Arms felt that if parents went to a shelter to adopt a puppy as a Christmas present for a child and were turned down, then the shelter might as well have given them a gift certificate to the pet store because that was where they were headed next.⁸⁹ They were not going to wait until after Christmas to get a puppy at the shelter. As for adopting out black cats near Halloween, he told the staff at North Shore that if they saw a broom parked outside then they could turn down the adopter.⁹⁰

In the 1970s, sales of AKC-registered puppies through pet stores was big business.⁹¹ A study done in one city in 1979 showed that over 40% of owned puppies had been purchased from breeders.⁹² Alex had expanded North Shore's hours so that North Shore could compete with the pet store in the mall that was open nights and weekends.⁹³ Arms wanted to continue to expand North Shore's market share so that his mixed breed puppies would have as much of a chance for a home as puppies from commercial breeders. This effort was so successful that North Shore was able to start transporting large numbers of homeless puppies to its shelter from other parts of the country.⁹⁴ North Shore provided initial funding for the Northeast Animal Shelter, founded in 1976, which became another leader in transporting pets from shelters in other parts of the country.⁹⁵

⁸⁷ Sharon Castellanos, "Mike Arms of HWAC," *Life + Dog*, accessed March 18, 2017, <http://www.lifeanddog.com/mike-arms/>.

⁸⁸ Mike Arms, interview by author, January 30, 2014; Mike Arms, email messages.

⁸⁹ Arms, interview; "Marketing Change: A Longtime Animal Welfare Leader Talks About How Shelters Can Better Promote Their Pets," *Animal Sheltering*, May-June 2009, 51–52.

⁹⁰ Arms, interview.

⁹¹ Martha Armstrong, Susan Tomasello, and Christyna Hunter, "From Pets to Companion Animals," in *The State of the Animals: 2001*, ed. Deborah Salem and Andrew Rowan (Washington, DC: Humane Society Press, 2001), 75.

⁹² R. Nassar and J. E. Mosier, "Canine Population Dynamics: A Study of the Manhattan, Kansas, Canine Population," *American Journal of Veterinary Research* 41, no. 11 (November 1980): 1798, 1801, table 5.

⁹³ Arms, email messages.

⁹⁴ Arms, interview.

⁹⁵ "About the Shelter," *Northeast Animal Shelter*, accessed April 22, 2017, <http://www.northeastanimalshelter.org/about-shelter/>; "Saving Homeless Pets Across America," *Northeast Animal Shelter*, accessed April 22, 2017, <https://www.northeastanimalshelter.org/our-programs/saving-homeless-pets-across-america/>.

North Shore used its own van to transport puppies,⁹⁶ and worked with several high intake, high kill shelters, primarily in the southern states. Puppies were often surrendered to those shelters without their mother, but if the mother was in the shelter too, North Shore sometimes brought her with the puppies.⁹⁷ In cases where the owners were keeping the mother, the shelter sending the puppies had to spay her.⁹⁸

North Shore also took in cats. As women went to work in larger numbers in the 1970s and 1980s, the popularity of cats as pets increased.⁹⁹ And landlords who said “no” to dogs in a highly urbanized area might allow a cat.¹⁰⁰ By 1989, 44% of pet adoptions at North Shore were cats.¹⁰¹

North Shore began in the early 1980s to make grants to other shelters to help them advertise their adoptable pets. One of the first cities that received this support was Denver, where North Shore provided the Dumb Friends League with funds for advertising in local newspapers.¹⁰² In Greensboro, North Carolina, the kill rate dropped after North Shore began assisting the shelter.¹⁰³ John Freed, the Greensboro shelter director, believed that North Shore had put puppy mills out of business throughout the United States by promoting the adoption of homeless animals.¹⁰⁴ North Shore also supported spay-neuter programs, spending more than \$3.5 million on pet sterilization programs in 1991 alone.¹⁰⁵

By 1990, North Shore’s shelter had space for 400 animals.¹⁰⁶ The organization was operating out of a complex of buildings that it had added over the years at its original location.¹⁰⁷ To modernize and add capacity, North Shore built a new 16,000 square foot shelter that opened in July of 1991.¹⁰⁸

In 1992, North Shore started the Pet Savers Foundation to manage its shelter assistance outreach programs.¹⁰⁹ The foundation included the Cooperative Advertising Initiative (which was eventually phased out), the SPAY USA program, the Cooperative Buying Program (a consortium to enable small shelters to buy supplies at lower cost), the Cooperative Adoption Program (using vans to transport animals and host adoption events across the country), national shelter conferences, and an educational program.¹¹⁰

North Shore expanded its veterinary services over time, and by the 1980s, it was offering comprehensive veterinary care and rehabilitation for its animals. A 1988 case that was featured in a *New York Times* article illustrated the extent to which North Shore veterinarians would go for a sick animal.¹¹¹ A puppy that had been brought to the shelter turned out to have a serious congenital heart defect that would soon kill it. There was a small possibility that open heart surgery could save the puppy’s life, so North Shore paid to have the puppy cared for in a foster home for a few weeks until he had matured enough to undergo the surgery. The

⁹⁶ Arms, interview.

⁹⁷ Arms, email messages.

⁹⁸ Arms, interview.

⁹⁹ Linda Saslow, “Adoption of Cats Increasing,” *New York Times*, June 24, 1990.

¹⁰⁰ Ibid.

¹⁰¹ Ibid.

¹⁰² Robert Rohde, interview by author, March 26, 2014.

¹⁰³ Clifton, “Cutting Euthanasia Rates and Choking Puppy Mills.”

¹⁰⁴ Ibid.

¹⁰⁵ Ibid.

¹⁰⁶ Saslow, “Adoption of Cats.”

¹⁰⁷ Hickerson, “Love for Animals.”

¹⁰⁸ Ibid.

¹⁰⁹ “Our History,” *The Pet Savers Foundation*, accessed March 18, 2017, <http://www.petsavers.org/history/>.

¹¹⁰ Ibid.

¹¹¹ Michael Winerip, “Our Towns; Drama in O.R.: Fighting to Save Puppy N-52471,” *New York Times*, April 19, 1988.

puppy unfortunately did not survive, but it was unusual in those days for a shelter to even try to save a puppy with such a poor prognosis.

Another veterinary case that had a happier outcome occurred in 1996. Firefighters found a badly burned mother cat and her five kittens at the site of a garage fire and took them to North Shore.¹¹² The case created a sensation in the media because the mother cat had apparently gone repeatedly into the burning garage, literally through fire, to carry her kittens to safety.¹¹³ When she arrived at North Shore, her ears, eyelids, stomach, and paws were burned and her eyes were swollen shut.¹¹⁴ The kittens, who were three or four weeks old, had less severe burns but were in danger from smoke inhalation.¹¹⁵ North Shore provided them with emergency care and rehabilitation. The mother cat, who was given the name Scarlett, and four of the kittens survived and were eventually placed in homes.¹¹⁶

One of Arms' lasting legacies to animal sheltering is the mass adoption event. While he was at North Shore, he pioneered marathon adoption extravaganzas that he called "adoptathons."¹¹⁷ Arms got the idea from marathon promotions that were popular with stores in the 1990s. The first North Shore adoptathon was held in 1995. It lasted 36 hours, from 9:00 a.m. Saturday to 9:00 p.m. Sunday.¹¹⁸ The media helped promote the event and reported on it afterward. In order to make it an occasion and attract the largest possible crowds, North Shore had events including a dance and a 4:00 a.m. coffee klatch. North Shore staff and volunteers stayed throughout the adoptathon. They brought their children, who slept on the floor. In later years, additional shelters were involved.

Adoptathons were very successful, and today many shelters in the United States and other countries have them.¹¹⁹ It is not unusual to have dozens or even hundreds of animals adopted out during an adoptathon at an individual shelter, and large events with multiple participating shelters have reached adoption numbers of 1,000 and more.

During Arms' 20-year tenure at North Shore, the shelter found adoptive homes for some 400,000 pets.¹²⁰ After Arms left North Shore in 1997, he developed another highly successful mass-marketing concept, "Home 4 the Holidays," which promoted adoption of shelter animals during the year-end holidays. The first Home 4 the Holidays event was held in December 1999 at the Helen Woodward Animal Center.¹²¹ By 2015, the Home 4 the Holidays event had reportedly found homes for over 12 million pets since its inception, with over 4,000 organizations participating.¹²² Home 4 the Holidays was a particularly important concept because it encouraged many traditional shelters to sign on to the idea Arms had always promoted, that the holidays are a great adoption opportunity for shelters.

North Shore was influential in bringing new ideas into sheltering during the crucial period from 1970 to 2000 when average shelter intake in the United States was declining and shelter workers in many places could begin to think about getting more animals out alive. Merritt Clifton reported in a 1993 article that North Shore

¹¹² Jane Martin and J. C. Suarès, *Scarlett Saves Her Family* (New York City: Simon & Schuster Editions, 1997), 23–32.

¹¹³ Joseph Fried, "Following Up," *New York Times*, March 4, 2001.

¹¹⁴ Martin and Suarès, *Scarlett Saves Her Family*, 36–37.

¹¹⁵ *Ibid.*, 36–37, 48.

¹¹⁶ *Ibid.*, 66–69.

¹¹⁷ Arms, interview.

¹¹⁸ *Ibid.*

¹¹⁹ "Our History of Innovation," *North Shore Animal League America*, accessed April 22, 2017, <http://www.animalleague.org/about-us/who-we-are/history/>.

¹²⁰ Castellanos, "Mike Arms of HWAC."

¹²¹ Arms, interview.

¹²² "Home 4 The Holidays," *Helen Woodward Animal Center*, accessed March 18, 2017, <http://www.animalcenter.org/home4theholidays/about.aspx>.

was placing more animals per year through adoption than any other shelter in the country and was providing more funds for sterilizing animals than any other national program in the country.¹²³

In spite of this success, North Shore was criticized for some of its innovations. One criticism was that North Shore's policy of transporting puppies from other states was taking homes away from local animals.¹²⁴ Arms saw it differently because he had observed that having puppies in the shelter could actually help local dogs get adopted by drawing more people away from pet stores and into the shelter. He put the puppies at the back of the adoption room, hoping that people would be distracted by one of the older dogs on their way to see the puppies.¹²⁵ If someone stopped and looked at a dog an attendant would ask the person to take the dog out for a walk.¹²⁶

Even after North Shore started doing transports, it continued taking in animals who were at risk in local public shelters. The ASPCA's director attributed a 34% reduction in the ASPCA kill rate from 1986 to 1992 in part to North Shore placing some 5,000 animals per year from the ASPCA shelter, as well as North Shore's funding of sterilization surgeries.¹²⁷ And the ASPCA's intake of dogs and cats, far from increasing due to transports of animals from the south, declined from 136,035 in 1974 to 50,443 in 1994.¹²⁸ Its kill rate declined from 86% to 77% over the same period. A North Shore spokesperson said in 1992 that North Shore had commissioned an independent group to evaluate intake to shelters on Long Island, and the group had concluded that intake to Long Island shelters had decreased by one-third over the previous 10 years.¹²⁹

North Shore's use of marketing techniques in the years from 1970 to 2000 correlated with what appears to have been an increasing acceptance of the idea of adopting a pet from a shelter. The Google Ngram Viewer¹³⁰ shows an increase in the use of the term "no kill" starting about 1970.¹³¹ The terms "animal shelter" and "pet adoption" both began a steady rise in the early 1970s. This was probably due to many factors, but the high profile of North Shore and its use of modern marketing techniques may have reached many people who otherwise would not have adopted from a shelter.

Private shelters like Bideawee and North Shore that saved all of their healthy and treatable animals were an important stage on the road to ending shelter killing, but they were not able in the 1970s and 1980s to save enough animals to end shelter killing in their jurisdictions. They coexisted with public shelters that killed a high percentage of their intake. The next great challenge for No Kill progress would be to expand the No Kill approach beyond private shelters to save all the homeless pets in a community, including the ones who were impounded at the public animal shelter. That effort is described in Parts V and VI. But one type of animal that could not be adopted out to a typical home was the feral cat. A different approach was needed for feral cats, and that is discussed in the next chapter.

¹²³ Clifton, "Cutting Euthanasia Rates and Choking Puppy Mills."

¹²⁴ See, e.g., Kenneth Allen, "Animal League Called Self-Serving," *New York Times*, December 29, 1991.

¹²⁵ Arms, interview.

¹²⁶ Ibid.

¹²⁷ Clifton, "Cutting Euthanasia Rates and Choking Puppy Mills."

¹²⁸ Stephen Zawistowski et al., "Population Dynamics, Overpopulation, and the Welfare of Companion Animals: New Insights on Old and New Data," *Journal of Applied Animal Welfare Science* 1, no. 3 (1998): 202, table 4, doi: 10.1207/s15327604jaws0103_1.

¹²⁹ Marge Stein, "How North Shore Handles Pets," *New York Times*, February 2, 1992

¹³⁰ Jean-Baptiste Michel et al., "Quantitative Analysis of Culture Using Millions of Digitized Books," *Science* 331, no. 6014 (January 2011): doi:10.1126/science.1199644.

¹³¹ "Ngram Viewer," *Google Books*, <http://books.google.com/ngrams>.

Chapter 14: Feral Cats and the Origin of TNR

Domestic cats in the United States have a variety of lifestyles. They have been classified by their ownership status (owned or unowned), where they spend their time (confined to a dwelling or free roaming) or socialization status (tame or feral).¹ Free roaming cats can be further subdivided into cats who split their time between indoors and outdoors, cats who are cared for by humans but who spend all their time outdoors, former pets (lost or abandoned), and feral cats.² The classification of cats is complicated by the fact that an individual cat's ownership status and lifestyle can change during its lifetime, and even socialization status can change to some extent.³

A more recent and perhaps simpler way to look at cats divides them into three classes: owned (the traditional pet relationship), stray (lost or abandoned cats), and community (cats who have no owner in the traditional sense, although they may have caregivers).⁴ Community cats may be tame or feral. They live on resources that are available in their area, including food and shelter that they may receive regularly or occasionally from humans. This three-part way of classifying cats is becoming very popular, as the community cat concept lends itself to practical management techniques that are discussed at the end of this chapter.



Figure 44:
Feral cat groups often include relatives who have similar coat colors. Photograph by Bob Adams, licensed under CC BY-SA 2.0.

“Feral” refers to the socialization status of a cat (untamed and evasive), not its ownership or where it spends its time,⁵ although feral cats are typically unowned and free roaming. A feral cat may have been born outdoors away from humans, or it may have been born in a home and then lost its home and gradually lost its acceptance of human contact.⁶ For the most thorough socialization, handling of a kitten should start by three weeks of age.⁷ A kitten that is not handled at all until it is eight weeks old may always be

¹ Julie Levy and Christine Wilford, “Management of Stray and Feral Community Cats,” in *Shelter Medicine for Veterinarians and Staff*, 2nd ed., ed. Lila Miller and Stephen Zawistowski (Ames, IA: Wiley-Blackwell, 2013), 669.

² *Ibid.*, 670, figure 41.1.

³ *Ibid.*, 669.

⁴ Julie Levy, email message to author, December 20, 2016.

⁵ Levy and Wilford, “Management of Stray and Feral Community Cats,” 669.

⁶ Roger Tabor, “General Biology of Feral Cats,” in Universities Federation for Animal Welfare, *The Ecology and Control of Feral Cats: Proceedings of a Symposium Held at Royal Holloway College, University of London, 23rd and 24th September 1980* (Hertfordshire, UK: Universities Federation for Animal Welfare, 1981), 5.

⁷ John Bradshaw, *Cat Sense: How the New Feline Science Can Make You a Better Friend to Your Pet* (2013; repr., New York: Basic Books, 2014), 77–78.

anxious around people.⁸ If socialization of a kitten is not begun by the time the kitten is 10 weeks of age, it may never be able to live as a typical pet.⁹ Many people who have cared for feral cats have reported, however, that some adult feral cats will become accepting of their caregivers over time. And there are anecdotal reports of adult cats who were not socialized as kittens but lived happily with humans as adults.

Feral cats may live singly, in groups of two or three, or in larger groups that are often called “colonies.”¹⁰ Many of the early studies of feral cats were done on colonies rather than on cats living singly or in small groups. Large colonies can form where food and shelter are abundant, and often consist of related females and their offspring.¹¹ The mother cats assist each other, including nursing and protecting each other’s kittens.¹² A colony of feral cats can contain more than one family if the food supply is plentiful enough, but families within a colony may compete, as well as cooperate.¹³

If a colony gets too big for its food sources, it may split, with the weaker faction forced out.¹⁴ Male kittens may leave their colonies starting as early as six months of age.¹⁵ Feral cat colonies sometimes include substantial numbers of non-feral cats who were raised in a home or were socialized to people when they were kittens and have since been abandoned or have strayed from home. Those individuals who are friendly toward people may be referred to as “stray” or “tame” rather than “feral.”

Cats can live in a variety of environments, but as a commensal species they thrive in or near human habitations.¹⁶ They are generally found in the greatest numbers in urban environments where shelter and concentrated food sources are available.¹⁷ Outdoor cats per unit of ground in urban areas outnumber outdoor cats in rural areas by more than 20 to 1.¹⁸ It may be that the great majority of outdoor cats depend in some fashion on resources supplied by humans.¹⁹

There have been no nationwide studies that have actually counted enough cats to permit a good estimate of the outdoor cat population in the United States, so estimates of the total number of outdoor or feral cats are perhaps more accurately characterized as educated guesses. One common guess is that the free roaming cat population may be as much as the owned cat population,²⁰ which in recent years has been estimated to be from 74 to 94 million.²¹ Other guesses of the number of unowned cats have ranged from

⁸ Ibid., 78, 87, 99.

⁹ Ibid., 100. Bradshaw describes anecdotes of adult feral cats who have become socialized to people after going through stressful experiences such as severe injury or a high fever and being nursed back to health. Ibid., 100–101.

¹⁰ Sharon Crowell-Davis, “Cat Behavior: Social Organization, Communication and Development,” in *The Welfare of Cats*, ed. Irene Rochlitz (Dort, NJ: Springer, 2005), 2; Dennis Turner, “Social Organization and Behavioral Ecology of Free-Ranging Domestic Cats,” chap. 5 in *The Domestic Cat: The Biology of Its Behavior*, 3rd ed., ed. Dennis Turner and Patrick Bateson (Cambridge, UK: Cambridge University Press, 2014), 66.

¹¹ Philip Baker, et al., “Domestic Cat (*Felis catus*) and Domestic Dog (*Canis familiaris*),” chap. 12 in *Urban Carnivores: Ecology, Conflict, and Conservation*, ed. Stanley Gehrt, Seth Riley, and Brian Cypher (Baltimore: Johns Hopkins University Press, 2010), 161, 163; Bradshaw, *Cat Sense*, 161.

¹² Crowell-Davis, “Cat Behavior,” 3.

¹³ Bradshaw, *Cat Sense*, 161–162; John Bradshaw, Rachel Casey, and Sarah Brown, *The Behavior of the Domestic Cat*, 2nd ed. (Wallingford, UK: CAB International, 2012), 144.

¹⁴ Bradshaw, *Cat Sense*, 174.

¹⁵ Ibid.; Turner, “Social Organization,” 66–67.

¹⁶ Terry O’Connor, *Animals as Neighbors: The Past and Present of Commensal Animals* (East Lansing: Michigan State University Press, 2013), 57–66.

¹⁷ Baker, et al., “Domestic Cat (*Felis catus*),” 161; Bradshaw, Casey, and Brown, *Behavior of the Domestic Cat*, 140.

¹⁸ Bradshaw, Casey, and Brown, *Behavior of the Domestic Cat*, 140.

¹⁹ Gary Patronek, “Special Report: Free-Roaming and Feral Cats—Their Impact on Wildlife and Human Beings,” *Journal of the American Veterinary Medical Association* 212, no. 2 (January 15, 1998): 218.

²⁰ Julie Levy, David Gale, and Leslie Gale, “Evaluation of the Effect of a Long-Term Trap-Neuter-Return and Adoption Program on a Free-Roaming Cat Population,” *Journal of the American Veterinary Medical Association* 222, No. 1 (January 1, 2003): 42, doi:10.2460/javma.2003.222.42.

²¹ “Pets by the Numbers: Data and Statistics on Pet Ownership, Community Cat, and Shelter Population in the United States,” *Humane Society of the United States*, accessed May 25, 2018, <https://www.animalsheltering.org/page/pets-by-the-numbers>.

10 to 120 million.²² Andrew Rowan, an expert on cat and dog populations, believes that it is highly unlikely that the current population of unowned cats in the United States is more than 30 to 40 million.²³

The capacity of feral cats to increase their population through reproduction is often exaggerated, sometimes wildly so, given that mortality of feral kittens is as high as 75%.²⁴ Because of this high mortality, at least some outdoor cat populations may require regular replenishment by stray and abandoned cats to maintain their numbers.²⁵ In the last 20 years, the percentage of people who keep their pet cats indoors is estimated to have increased from 25% to 65%,²⁶ which might be affecting populations of outdoor cats in some areas.

Animal control operations traditionally dealt with complaints about feral cats by capturing the cats and killing them, or making traps available for people to catch cats and bring them to the shelter to be killed. Cat advocates sought a better way to control outdoor cat populations, which led to the development of a non-lethal method of control known as Trap-Neuter-Return (TNR). As the TNR procedure evolved, it was called by a variety of names, including “trap-sterilize-release,”²⁷ “trap and release,”²⁸ and “trap, neuter, vaccinate, return.”²⁹ “TNR” became the most widely accepted acronym for the procedure by the 2000s.³⁰ Although the words “release” and “return” have both been used as part of “TNR” over the years, there is an important distinction. The preferred method is to return cats to their colony, when possible, not simply release them.³¹

There is vigorous debate about whether TNR reduces outdoor cat populations. Rowan points out that shelter intake of cats is estimated to have declined by 75% since 1970.³² Shelter intake policies on impoundment of cats are not uniform, and can change over time, but such a large drop in cat intake could indicate that some factor or set of factors is causing the number of free-roaming cats to decline. Julie Levy, a veterinarian who is an expert on cat population dynamics, believes that it is difficult to characterize the effect of sterilization efforts on the outdoor cat population to date due to the many variables involved.³³ The practice of TNR has gained wide acceptance as a humane population management measure, though, even if it has not been definitively proven to reduce the number of outdoor cats.

²² Six articles that were cited in a 2013 meta-analysis addressed the issue of the unowned cat population in the United States, with proposed estimates ranging from 10 to 120 million. Scott Loss, Tom Will, and Peter Marra, “The Impact of Free-Ranging Domestic Cats on Wildlife of the United States,” *Nature Communications* 4 (January 29, 2013): Supplementary Information, discussion and table S2, doi:10.1038/ncomms2380.

²³ Andrew Rowan, email message to author, November 17, 2016; “Pets by the Numbers.”

²⁴ Baker, et al., “Domestic Cat (*Felis catus*),” 164; Felicia Nutter, Jay Levine, and Michael Stoskopf, “Reproductive Capacity of Free-Roaming Domestic Cats and Kitten Survival Rate” *Journal of the American Veterinary Medical Association* 225, no. 9 (November 1, 2004): 1400, doi:10.2460/javma.2004.225.1399.

²⁵ Patronek, “Special Report: Free-Roaming and Feral Cats,” 223.

²⁶ Andrew Rowan, interview by author, April 29, 2014.

²⁷ Tufts University School of Veterinary Medicine, “Beyond the Hearth: Helping the Homeless Cat,” *Catnip, A Newsletter for Caring Cat Owners*, March 1994, 4–5.

²⁸ Louise Holton, “Feral Cats Find Friends in Alley Cat Allies,” *Latham Letter*, Spring 1993, 12.

²⁹ Tufts University School of Veterinary Medicine, “Cat Colonies,” *Catnip*, June 1998, 1.

³⁰ See, e.g., “1st Annual National Feral Cat Day Proclaimed,” *Alley Cat Action*, Fall 2001, 1. The most elaborate monikers for the TNR procedure were TTVAR for Trap-Test-Vaccinate-Alter-Release (or Return), and TTVAR-M, which adds Manage (or Monitor or Maintain). Ellen Perry Berkeley, *TNR Past Present and Future: A History of the Trap-Neuter-Return Movement* (Washington, DC: Alley Cat Allies, 2004), 1.

³¹ Berkeley has pointed out that opponents of TNR have used the term “release” to argue that TNR constitutes abandonment. Berkeley, *TNR Past Present and Future*, 13, 25, 27.

³² Rowan, email message.

³³ Julie Levy, email messages to author, December 20, 2016 and March 6, 2016.

The basic concept of TNR is straightforward—individuals, usually volunteers, capture unowned cats, take them to a clinic for sterilization and vaccination against rabies, and return them to their territory. Tame adults and kittens who are young enough to be socialized may be held for adoption. TNR is ideally combined with ongoing monitoring of the cats by caregivers who can provide food, get medical care for cats who need it, identify new cats who move into the area and get them sterilized, and find adopters for kittens. TNR is a unique solution for the unique blend of wild and domestic in the feral cat. It recognizes their preference to live without close human contact but does not leave them entirely on their own.



Figure 45:
This cat is pictured while recovering after TNR, and was released where it was captured.
Photograph by Feline Avenger, licensed by CC BY-SA 3.0.

Many different people in several countries appear to have independently developed the idea to start sterilizing feral cats in their neighborhood or community. A few people in England were known to have done TNR as early as the 1950s.³⁴ One of the earliest efforts to document the effect of TNR was carried out in England by Celia Hammond, who was a well-known fashion model.³⁵ She began trapping and sterilizing feral cats in the 1960s and finding them homes.³⁶ In 1971, during a time when she was unable to find enough homes, she began putting the cats back where she found them as a temporary measure.³⁷ This worked so well that she began to use it as a regular practice, and grew to regard finding homes for adult feral cats as a “hopelessly inefficient way to deal with the problem.”³⁸ Before long, Hammond had documented hundreds of colonies in both urban and rural locations.³⁹

English biologist, Roger Tabor, researched feral cat ecology in the 1970s and 1980s, and identified a “vacuum effect” that occurred when all members of a cat colony in an area that offered food and shelter were removed.⁴⁰ Instead of the area remaining free of cats, other cats moved in to take advantage of the conditions that supported the original group of cats. He argued that sterilizing the members of a cat colony and allowing them to remain in their territory gradually reduced colony numbers without triggering the vacuum effect.⁴¹

³⁴ Jenny Remfry, *Ruth Plant: A Pioneer in Animal Welfare* (Barnet, UK: Falkland Press, 2001), 49.

³⁵ “About Celia,” *Celia Hammond Animal Trust*, accessed April 23, 2017, <http://www.celiahammond.org/index.php/about-us/about-celia>.

³⁶ Berkeley, *TNR Past Present and Future*, 2.

³⁷ Remfry, *Ruth Plant*, 49–50.

³⁸ Celia Hammond, “Long Term Management of Feral Cat Colonies,” in Universities Federation for Animal Welfare, *Ecology and Control of Feral Cats*, 89.

³⁹ *Ibid.*

⁴⁰ Tabor, “General Biology of Feral Cats,” 9.

⁴¹ Roger Tabor, *The Wild Life of the Domestic Cat* (1983; repr., London: Arrow Books, 1984), 185.

The various strands of research in support of sterilization and maintenance programs for feral cats in England were brought together by the Universities Federation for Animal Welfare (UFAW).⁴² UFAW was so important in promoting TNR in the early years that neuter-and-return programs were sometimes referred to as “the UFAW method.”⁴³ In September of 1980, UFAW held a symposium in London called “Ecology and Control of Feral Cats.”⁴⁴ Jane Dards, a researcher who studied feral cats at a dockyard in England for four years, presented a paper reporting that the cats she studied were generally in good condition, thus challenging the idea that feral cats inevitably led lives of starvation and suffering.⁴⁵ (The conclusion that many feral cats have sufficient food and shelter was echoed by ecological studies done on free roaming cats in Baltimore and Brooklyn in the 1980s, as discussed in chapter 8.) Another important contributor to the symposium was Jenny Remfry, a veterinarian who was central to UFAW’s feral cat programs. She spoke about “trapping, neutering, and returning to site,”⁴⁶ which was one of the earliest iterations of the words that were later abbreviated as “TNR.”



Figure 46:
The tip of a cat’s ear is removed during TNR so that in the future, the cat does not have to be captured and examined to see if it has been sterilized. “Feral Cat ‘Buster’” by Professor Batty is licensed under CC BY-2.0.

Hammond spoke at the 1980 symposium, observing that sterilization had stabilized the colonies she studied “without any detrimental effect whatsoever.”⁴⁷ She reported that the nuisance behaviors of spraying and fighting were eliminated after the cats were sterilized.⁴⁸ The cats became more docile, which made it easier for their caregivers to trap them when they needed medical attention.⁴⁹ It was common in her experience for colonies to grow to 20 to 30 cats.⁵⁰

Tom Kristensen of Denmark, who was a speaker at the 1980 symposium, described the Danish method of removing the tip of one ear to identify a cat who has been sterilized and returned to its territory.⁵¹ At first, there was resistance to ear tipping from people who felt that it was mutilation. Other methods, such as tattooing, were tried, but did not allow sterilized cats to be identified at a distance. Eventually, virtually everyone agreed that the slight detriment of the clipped ear was preferable to putting an already sterilized feral

⁴² Remfry, *Ruth Plant*, 60–67; “A History of Improving Animal Welfare,” UFAW, accessed April 23, 2017, <https://www.ufaw.org.uk/about-ufaw/history-of-ufaw>.

⁴³ Ellen Perry Berkeley, “Feral Cats,” *Cat Fancy* 33, no. 7 (July 1990), 20.

⁴⁴ Universities Federation for Animal Welfare, *Ecology and Control of Feral Cats*.

⁴⁵ Jane Dards, “Habitat Utilization by Feral Cats in Portsmouth Dockyard,” in Universities Federation for Animal Welfare, *Ecology and Control of Feral Cats*, 43.

⁴⁶ Jenny Remfry, “Strategies for Control,” in Universities Federation for Animal Welfare, *Ecology and Control of Feral Cats*, 79.

⁴⁷ Hammond, “Long Term Management of Feral Cat Colonies,” 89.

⁴⁸ *Ibid.*, 90.

⁴⁹ *Ibid.*

⁵⁰ *Ibid.*, 91.

⁵¹ Tom Kristensen, “Feral Cat Control in Denmark,” in Universities Federation for Animal Welfare, *Ecology and Control of Feral Cats*, 70.

cat through the trapping process again and possibly subjecting it to unnecessary surgery. A clearly visible ear tip can also protect a cat from being picked up by animal control in communities where TNR is an accepted method of cat management. The clipped ear is now the universal sign of the unowned cat who has been sterilized.

TNR increased in popularity in England in the 1980s as techniques and materials for sterilization surgeries on unsocialized cats were perfected.⁵² UFAW published a guide to feral cat control in 1982 that became the agency's best seller. It was reprinted in 1984, revised in 1985, published as a second edition in 1989, and reprinted in an expanded version in 1995.⁵³ One of the tools described by the UFAW guide was the squeeze cage, which has a moveable panel that allows a cat to be given a sedative before the cat is removed from the cage.⁵⁴

UFAW's educational materials in the 1980s put forward an argument in favor of TNR that proponents would use many times in the years ahead. The argument was that there are only three options for dealing with feral cats: leave them alone (which allows them to continue to multiply), try to kill them all (which is ineffective and strongly resisted by cat caregivers), or TNR (which controls their numbers and reduces nuisance behaviors).⁵⁵ The dissemination by UFAW of scientific and ecological studies on nonlethal control programs gave credibility to the budding movement to sterilize feral cats and return them to their territories rather than kill them.

Meanwhile, the earliest TNR programs were developing in the United States. Jessie Manuel founded Animal Birth Control (ABC) in Ocean County, New Jersey, in 1969, and incorporated it in March of 1970.⁵⁶ ABC's primary purpose was to help make low-cost sterilization available for owned pets, but occasionally the organization would get requests for help with feral cats.⁵⁷ Manuel learned how to trap feral cats from Rita Surdi, who by the mid-1970s had started trapping feral cats in Toms River and taking them to a veterinarian for sterilization. Joan Lugo, another member of ABC, began doing TNR in Tuckerton, New Jersey, in the 1970s. They apparently devised their TNR method on their own as a common-sense approach to help feral cats in their communities.

Many of the members of ABC were people who had volunteered at shelters in the area and had seen the problem of dog and cat overpopulation first-hand. Virginia Merry, who joined ABC in 1977, recalled that when she moved to a town in Ocean County in 1963, it "was just full of cats."⁵⁸ In the early years, they had difficulty finding veterinarians who would work with feral cats. When ABC received a call for help with feral cats, it was usually from a person who had feral cats on their property and wanted to help them. ABC put advertisements in the local newspaper to assist people in placing kittens born on their property.

Another early group that helped feral cats in the United States was Forgotten Felines of Valhalla, New York.⁵⁹ They were trapping, sterilizing, and releasing feral cats by 1982,⁶⁰ but did not incorporate until

⁵² Remfry, *Ruth Plant*, 72.

⁵³ *Ibid.*, 63; Universities Federation for Animal Welfare, *Feral Cats: Suggestions for Control*, 2nd ed. (Hertfordshire, UK: Universities Federation for Animal Welfare, 1989).

⁵⁴ Universities Federation for Animal Welfare, *Feral Cats: Suggestions for Control*, 10–11.

⁵⁵ Universities Federation for Animal Welfare, videotape, transcribed in *Overpopulation of Cats and Dogs: Causes, Effects, and Prevention*, ed. Marjorie Anchel (New York: Fordham University Press, 1990), 58–59.

⁵⁶ Virginia Merry, interviews by author, April 3, 2014, and September 2015; State of New Jersey, Business Records Service.

⁵⁷ Merry, interviews.

⁵⁸ *Ibid.*

⁵⁹ Olga Klimek, interview by author, August 18, 2015.

⁶⁰ *Ibid.*

October of 1986.⁶¹ The group had a network of veterinarians who provided discounted sterilizations and gave rabies shots.⁶² They adopted out kittens and friendly adult cats, and they returned cats who were too unsocialized for adoption to their territories or found safe locations for them with colony caregivers. Males were released the day after surgery and females were held for three or four days. Carol Davis, the president of Forgotten Felines, provided the use of her home for holding the cats. Both ABC and Forgotten Felines still exist today.

A 1982 TNR project started by two staff members at the Fernald State School in Waltham, Massachusetts, sterilized feral cats on its grounds.⁶³ As of 1990, the Fernald school had 12 colony caregivers, the cats were doing well, and the school regarded them as an asset rather than a nuisance.

Ellen Perry Berkeley, a writer and editor from Vermont, wrote influential books and articles starting in the 1980s that played a major role in bringing attention to feral cats in the United States. Her book *Maverick Cats*, published in 1982, had descriptions of the feral cats on her rural property juxtaposed with what researchers had to say about feral cats.⁶⁴ In 1984, Berkeley wrote a lead article for *Cat Fancy* magazine discussing TNR in England.⁶⁵ One UFAW project that Berkeley described showed that costs for TNR at an urban housing project, with volunteer labor and reduced veterinary fees, was much less than a pest control company would charge to catch and kill cats. The cost savings were even greater when looked at on a 10-year scale, since colony caregivers provided free ongoing management whereas a pest control company would have to be paid every two years to repeat a catch-and-kill program. This article provided people who wanted to try TNR with both inspiration and persuasive evidence that it was better than the alternatives.



Figure 47:
Author Ellen Perry Berkeley.

The annual conference of the World Society for the Protection of Animals was held in Boston in 1984, and Peter Neville of UFAW spoke about feral cat programs in England.⁶⁶ AnnaBell Washburn, the founder of a rescue organization on Martha's Vineyard, attended the conference and heard Neville speak. She was intrigued, and soon afterwards made a trip to England to learn more.⁶⁷ She met with Remfry, who gave her a squeeze cage. When Washburn returned to Martha's Vineyard, she and a group of volunteers started trapping and sterilizing cats, and in four years they sterilized almost 200 feral cats.⁶⁸

⁶¹ NYS Department of State, Division of Corporations Entity Information.

⁶² Klimek, interview.

⁶³ Berkeley, "Feral Cats," 25–26.

⁶⁴ Ellen Perry Berkeley, *Maverick Cats: Encounters with Feral Cats* (New York: Walker & Company, 1982). An expanded and updated edition of this classic was published in 2001. Berkeley, *Maverick Cats: Encounters with Feral Cats*, 2nd. ed. (Shelburne, VT: New England Press, 2001).

⁶⁵ Ellen Perry Berkeley, "Controlling Feral Cats," *Cat Fancy* 27, no. 9, September 1984, 16–19.

⁶⁶ AnnaBell Washburn, "Control of Feral Cats," in *Overpopulation of Cats and Dogs*, 62.

⁶⁷ *Ibid.*, 63.

⁶⁸ Berkeley, "Feral Cats," 22.

Washburn soon found another island that needed feral cat control when she visited Virgin Gorda in the British Virgin Islands.⁶⁹ As was the case on many islands, humans had brought in cats in an effort to control rats, only to have the cat population grow and become a nuisance. Washburn worked with the Tufts University School of Veterinary Medicine to set up internships on Virgin Gorda for senior veterinary students to do TNR under supervision by professors.⁷⁰ Over the four years of the program, they sterilized 361 cats.⁷¹

By the mid-to-late 1980s, there were many people doing TNR in the United States. A TNR program was started by the Feline Medicine Club at the University of California at Davis in 1986.⁷² The Animal Umbrella group was at work in Boston by 1987 to provide support to colony caregivers throughout the Boston area.⁷³ In 1989, the Stanford Cat Network was founded at Stanford University in California by a group of volunteers led by Carole Miller and Carole Hyde.⁷⁴ The original population of cats at Stanford, estimated variously as 500 to 1,500, was reduced to 85 by 2004.⁷⁵

Two important events in the United States in 1990 kicked off a decade of rapid progress in TNR. The first was the appearance of a lead article by Berkeley in *Cat Fancy* describing the work of Washburn and others.⁷⁶ The article included information on how to do TNR and where to get help.⁷⁷ It described the use of dissolvable surgical stitches, a relatively new technology that obviated the need for trapping cats a second time to remove stitches.⁷⁸ Berkeley mentioned several TNR projects that were underway at the time, including ones in Nevada, Pennsylvania, Idaho, Colorado, Utah, and Arizona.⁷⁹ This article attracted even more attention than Berkeley's 1984 article on the UFAW neuter-and-release projects in England.

The second major event in 1990 was the formation of an organization, Alley Cat Allies, that would become the dominant voice for feral cats in the United States. One evening in July of 1990, Becky Robinson, an animal welfare activist in Washington, DC, was walking to a restaurant in the Adams Morgan neighborhood to meet a friend when she came across a colony of beautiful, healthy, tuxedo feral cats.⁸⁰ By coincidence, the person Robinson was meeting for dinner that night was Louise Holton. Holton, who was from South Africa, was familiar with TNR procedures because she had done TNR in Johannesburg in the 1970s.⁸¹ She had contacted UFAW back then for information.⁸²

The Adams Morgan cats had caretakers, but the caretakers did not know how to get the cats sterilized. Robinson and Holton talked the situation over and decided to set up a TNR program for the cats. The process of helping the Adams Morgan cats taught Robinson and Holton first-hand about the difficulties

⁶⁹ Washburn, "Control of Feral Cats," 64.

⁷⁰ *Ibid.*, 66.

⁷¹ Berkeley, "Feral Cats," 25.

⁷² Berkeley, TNR Past Present and Future, 44–45.

⁷³ Berkeley, "Feral Cats," 26.

⁷⁴ Elizabeth Bacon, "Stanford Cat Network Celebrates Fifth Anniversary," Stanford University News Service, January 5, 1994, accessed March 18, 2017, <http://news.stanford.edu/pr/94/940105Arc4519.html>. The Stanford Cat Network has been renamed the Feline Friends Network, and still exists today. "About Us," Feline Friends Network, accessed April 24, 2017, <http://felinefriendsnetwork.org/about-us/>.

⁷⁵ Margaret Slater and Stephanie Shain, "Feral Cats: An Overview," in *The State of the Animals III*: 2005, ed. Deborah Salem and Andrew Rowan (Washington, DC: Humane Society Press, 2005), 44; "About Us," Feline Friends Network.

⁷⁶ Berkeley, "Feral Cats," 20–27.

⁷⁷ *Ibid.*, 22, 24.

⁷⁸ *Ibid.*, 24.

⁷⁹ *Ibid.*, 26.

⁸⁰ "Becky Robinson," *Best Friends Magazine*, November–December 2011, 22; "The Journey to Now," *Alley Cat Action*, Fall 2001, 4; Betsy Siino, "Helping Hands: Alley Cat Allies," *Cat Fancy*, August 1994; Becky Robinson, interview by author, March 28, 2014.

⁸¹ Louise Holton, email message to author, September 9, 2015.

⁸² *Ibid.*

involved and the lack of resources for help.⁸³ In the absence of resources from humane organizations in the United States, they modeled their procedures on the UFAW method. At that time, most veterinarians had no training in handling feral cats, and it took Robinson and Holton many telephone calls to locate a veterinarian who would sterilize the cats.

Word quickly got around among feral cat caregivers about what Robinson and Holton were doing, and they began to receive dozens of phone calls from people who were desperate for help.⁸⁴ Colony caregivers were frequently reluctant to ask for help from authorities for fear that animal control would force them to stop caring for cats, or even round up the cats and kill them. Robinson's experience in community organizing for animal welfare and Holton's experience with TNR meant that they were well positioned to fill the information gap. They formally incorporated Alley Cat Allies in 1991,⁸⁵ and Berkeley and Washburn joined the board of advisors.⁸⁶ Donna Wilcox, who joined Alley Cat Allies soon after it was formed, became an important part of the organization.

By early 1991, Robinson and Holton were traveling around the country giving TNR workshops.⁸⁷ They started a newsletter in June 1991, *Alley Cat Action*, that is still published today.⁸⁸ Holton contacted Remfry, then went to London where she met with Tabor.⁸⁹ She invited Remfry and Tabor to visit the United States to help spread the word about TNR. One of the most important early endeavors of Alley Cat Allies was the Feral Friends Network. The network was created in 1993 as a way of formalizing the important function of connecting people who wanted to do TNR with experienced caretakers and veterinarians.⁹⁰

Alley Cat Allies has been very active in working with local advocates who are trying to create a climate favorable to TNR in their cities and towns.⁹¹ Laws affecting feral cats vary from one state to another, treating the cats as everything from strays to colony residents to wildlife.⁹² In many jurisdictions, the legal status of feral cats is unspecified.⁹³ Special ordinances that govern TNR may require registration of caregivers, or may impose guidelines or restrictions.⁹⁴ Throughout the 1990s, TNR was questioned or opposed by many in the humane community. Alley Cat Allies continued to provide information on TNR, hold conferences, help people network, promote TNR with policymakers, and fight anti-TNR proposals.⁹⁵

Other organizations were also working on feral cat issues. The Feral Cat Coalition, located in San Diego County, California, developed a high-volume TNR clinic in 1992.⁹⁶ Sally Mackler realized the need for such a clinic when she was working a telephone help line for spay-neuter services and received

⁸³ Robinson, interview.

⁸⁴ Ibid.

⁸⁵ "The Journey to Now," 4. Holton formed another organization, Alley Cat Rescue, in 1997, and she left Alley Cat Allies in 2001. "Farewell to a Founder," *Alley Cat Action*, Summer 2001, 2; Holton, email message.

⁸⁶ "TNR Week: A Brief History of TNR—Q & A with Ellen Perry Berkeley," *Modern Cat*, September 14, 2010, <http://www.moderncat.net/2010/09/14/tnr-week-a-brief-history-of-tnr-qa-with-ellen-perry-berkeley/>; "AnnaBell Washburn, The Guiding Spirit of TNR," *Alley Cat Action*, Fall 2001, 3.

⁸⁷ "The Journey to Now," 4.

⁸⁸ "ACA's Feral Friends Network: Helping People Help Feral Cats," *Alley Cat Action*, Spring 2003, 1.

⁸⁹ Holton, email message.

⁹⁰ "The Journey to Now," 4; "ACA's Feral Friends Network," 1.

⁹¹ "What is Alley Cat Allies? What Has It Done?," *Alley Cat Action*, Fall 2001, 1, 8; Becky Robinson, *The Evolution of the Cat Revolution: Celebrating 25 Years of Saving Cats* (Bethesda, MD: Alley Cat Allies, 2015), 15.

⁹² Susan Hunter and Richard Brisbin, Jr., *Pet Politics: The Political and Legal Lives of Cats, Dogs, and Horses in Canada and the United States* (West Lafayette, IN: Purdue University Press, 2016), 10, 285–304.

⁹³ Ibid., 287.

⁹⁴ Ibid., 298–300.

⁹⁵ "The Journey to Now," 4.

⁹⁶ Slater and Shain, "Feral Cats: An Overview," 44.

many calls from people who wanted to sterilize feral cats.⁹⁷ She teamed up with a veterinarian, Rochelle Brinton, to create the clinic.⁹⁸ With volunteer help, the clinic could handle up to 200 cats per day.⁹⁹ San Diego County reported an almost 50% drop in the number of cats killed at the animal shelter within five years after the TNR clinic started.¹⁰⁰ This program became a source of information for many other organizations. For example, Julie Levy visited the Feral Cat Coalition circa 1994 and used some of its techniques to increase the volume of surgeries at “Operation Catnip” clinics in Raleigh, North Carolina, and Gainesville, Florida.¹⁰¹

Another important event in 1992 was the formation of the Merrimack River Feline Rescue Society (MRFRS), in Newburyport, Massachusetts, by a group of people concerned about a colony of feral cats living along the Merrimack River.¹⁰² They created a suite of services to help cats, including a shelter where socialized cats could be housed while awaiting adoption. The last member of the original colony died in 2009, and today the MRFRS shelter is able to take in and place kittens from other communities.¹⁰³

TNR was very much a grassroots phenomenon in the 1990s, and it spread from one community to another. An example of this process was the program developed by the Neponset Valley Humane Society (NVHS) based on information from Alley Cat Allies.¹⁰⁴ The NVHS, a private No Kill shelter, was founded in 1993 by Bonney Brown in a town outside of Boston.¹⁰⁵ In the fall of 1994, an animal control officer from nearby Norwood, Massachusetts, contacted NVHS for advice about feral cats.¹⁰⁶ Animal control in Norwood had been capturing feral cats and killing them, but public criticism had led officials in Norwood to seek a non-lethal alternative.¹⁰⁷ NVHS called a meeting for people interested in forming a TNR group and 40 people responded, including a veterinarian, an attorney, and a CPA.¹⁰⁸ The Cat Action Team of Norwood began trapping and sterilizing cats in January 1995.¹⁰⁹ Eleven veterinarians were involved with the program, all of whom provided services free or at low cost.¹¹⁰ In addition to being sterilized, the cats received rabies vaccinations.¹¹¹

A few months later, NVHS helped people in the neighboring town of Sharon form a Cat Action Team and start their own TNR program.¹¹² NVHS provided training, equipment, and referrals to veterinarians.¹¹³ Brown heard that another local town, Foxboro, was considering what to do about its feral cats, and on December 2, 1995, she sent their Board of Selectmen a letter outlining the establishment of the Cat Action

⁹⁷ “Friend of Ferals,” *Maddie’s Fund*, accessed April 24, 2017, <http://www.maddiesfund.org/friend-of-ferals.htm?p=topic37>.

⁹⁸ *Ibid.*

⁹⁹ Slater and Shain, “Feral Cats: An Overview,” 44. In addition to labor, many of the supplies were donated. As of 1996 the Feral Cat Coalition was spending only about \$3.50 per sterilization. Ray Savage, “Position Paper,” in *Scientific Workshop: A Critical Evaluation of Free-Roaming/Unowned/Feral Cats in the United States*, American Humane Association/Cat Fanciers Association, August 1996, 52.

¹⁰⁰ Margaret Slater, *Community Approaches to Feral Cats: Problems, Alternatives, and Recommendations* (Washington, DC: Humane Society Press, 2002), 39; Kim Sturla, “Fixing the Feline,” *Animal’s Agenda*, September-October 1997, 35–36; “Cutting Euthanasias Without Conflict” *Animal People*, March 1996, 8.

¹⁰¹ Slater and Shain, “Feral Cats: An Overview,” 44; Levy, e-mail messages.

¹⁰² “About MRFRS,” *Merrimack River Feline Rescue Society*, accessed March 19, 2017, <http://mfrfs.org/about-mfrfs/>.

¹⁰³ *Ibid.*

¹⁰⁴ Marie O’Neil, “Controlling the Feral Cat Explosion,” *South Look/Mariner Newspapers*, March 8–9, 1995.

¹⁰⁵ Neponset Valley Humane Society, Commonwealth of Massachusetts Articles of Organization, filed February 22, 1993.

¹⁰⁶ “Citizen’s Committee Forms to Deal with Feral Cats,” *Daily Transcript*, November 23, 1994.

¹⁰⁷ O’Neil, “Controlling the Feral Cat Explosion.”

¹⁰⁸ *Ibid.*

¹⁰⁹ “Cat Action Team Meets Tonight,” *Daily Transcript*, January 10, 1995.

¹¹⁰ O’Neil, “Controlling the Feral Cat Explosion.”

¹¹¹ *Ibid.*

¹¹² Susan Misicka, “Program to Manage Stray, Feral Cats,” *Patriot Ledger*, April 25, 1995.

¹¹³ Aaron Nicodemus, “Animal Lovers Aim to Neuter Feral Cats,” *Sharon Advocate*, March 17, 1995.

Teams of Norwood and Sharon. She provided telephone contacts, an offer of financial support, and an offer to make a presentation about TNR to the Board, and attached 152 pages of documentation on TNR. At a meeting on December 12, 1995, which was attended by TNR advocates from several groups, the Foxboro Board of Selectmen agreed to support a Cat Action Team to be run by volunteers at no cost to taxpayers.¹¹⁴

In a presentation to the Massachusetts Veterinary Medical Association in February 1997, Brown reported that NVHS had sterilized over 3,000 feral cats and 1,000 companion cats. There was so much interest in TNR that she developed a package to use in speaking to city officials, veterinarians, and other animal welfare advocates. She stressed that the benefits of TNR included preventing the breeding of cats, preventing rabies by vaccinating the cats, reducing in-migration of new cats, and eliminating nuisance behaviors like yowling, fighting, and spraying. She noted that trap-and-kill methods could kill pet cats, a danger that was avoided with TNR.

Brown pointed out in her presentations that there were many people who were ready to volunteer and donate money for TNR programs, but those same people would strongly oppose trap-and-kill programs. Resistance to trap-and-kill would almost guarantee the failure of such programs, as people who cared for feral cats would do everything they could to hide the cats from authorities. By contrast, feral cat caregivers have a motivation to step forward and identify their colonies when they know that community officials support TNR as the default choice for feral cats. TNR, therefore, may have a better chance of reaching all the feral cats in a community than trap-and-kill. The necessity of protecting humans and non-target animals from whatever method is chosen to kill cats is another obstacle for catch-and-kill programs.

One contentious issue with TNR in the 1990s was whether to test feral cats for Feline Immunodeficiency Virus (FIV) and Feline Leukemia Virus (FeLV), and euthanize the ones who tested positive. Feral cats are infected with the viruses in about the same proportion as the general cat population (around 4%), and cats who are infected with the viruses can potentially infect other cats.¹¹⁵ The decision is complicated, and recommendations about how to handle this issue have changed over time. Screening tests may give false positives, and feral cats who are infected can often live relatively normal lives, especially if they have a caregiver. In the 1990s, many people recommended euthanizing cats who tested positive for FeLV or FIV.¹¹⁶ Today, most large-scale TNR programs do not test for FeLV or FIV due to the cost and impracticality of testing, as well as the fact that the behaviors that can transmit the diseases are less frequent in sterilized cats.¹¹⁷

Conferences in the 1990s were important in developing TNR as a veterinary procedure and a policy alternative. In 1992, the Tufts University School of Veterinary Medicine hosted a one-day workshop on feral cats.¹¹⁸ On July 8, 1994, Alley Cat Allies presented Focus on Ferals, a national conference on feral cat issues in Washington, DC.¹¹⁹ Speakers included Tabor, Remfry, and Washburn. The Doris Day Animal League coordinated with Alley Cat Allies to hold a roundtable in connection with the conference where different views about feral cats were presented.¹²⁰ That same year, the Summit for the Animals passed a conference resolution proposed by Alley Cat Allies endorsing nonlethal feral cat control.¹²¹

¹¹⁴ Jeff Peterson, "Feline Fanciers Find Foxboro Fantastic," *Foxboro Reporter*, December 14, 1995.

¹¹⁵ Levy and Wilford, "Management of Stray and Feral Community Cats," 673.

¹¹⁶ See, e.g., Tufts University School of Veterinary Medicine, "Beyond the Hearth," 5.

¹¹⁷ Levy and Wilford, "Management of Stray and Feral Community Cats," 674.

¹¹⁸ Slater and Shain, "Feral Cats: An Overview," 45; Berkeley, *TNR Past Present and Future*, 11.

¹¹⁹ "The Journey to Now," 4; Robinson, *Evolution of the Cat Revolution*, 5, 14.

¹²⁰ Berkeley, *TNR Past Present and Future*, 11.

¹²¹ Louise Holton, "Position Paper," in *Scientific Workshop*, 10.

In August of 1996, the American Humane Association and the Cat Fanciers Association held a three-day scientific workshop in Denver on feral cats called “A Critical Evaluation of Free Roaming/Unowned/Feral Cats in the U.S.”¹²² Representatives from 47 humane organizations attended, as well as 10 scientists.¹²³ Many prominent feral cat advocates presented papers, including Holton and Brown. The seminar addressed the state of knowledge on feral cats and the question of whether TNR was superior to the trap-and-kill method for managing free roaming cats. Out of 41 papers presented by the humane organizations, 40 argued for TNR.¹²⁴ At a 1997 seminar sponsored by SpayUSA, Esther Mechler noted that there was growing agreement that TNR was the best strategy for recruiting volunteers and reducing the number of feral cats to a manageable level.¹²⁵

Notwithstanding the steady increase in acceptance of TNR in the 1990s, it faced (and still faces) determined opposition from some wildlife conservationists who argue that free roaming cats harm populations of native fauna, especially birds.¹²⁶ Other scientists point out that cats are specialized predators of small mammals.¹²⁷ In the continental United States, ground dwelling rodents are common prey for cats.¹²⁸ Bird conservationists often argue for a combination of confinement and catch-and-kill methods to reduce the number of outdoor cats. TNR proponents respond that the general public does not support catch-and-kill methods and that TNR offers the most effective method to reduce outdoor cat populations and reduce predation. Nevertheless, in many cities and counties opposition by bird conservationists has stymied TNR programs.

The traditional shelter industry was generally opposed to TNR in the 1990s. Many shelter workers believed that feral cats lived short, miserable lives and that a painless death in the shelter was a kindness for them. They believed that cats, like dogs, needed to live in homes with people in order to have an acceptable quality of life.¹²⁹ A 2006 study that looked at reports of over 103,000 sterilizations of feral cats in clinics found, however, that only 0.4% of the incoming cats had to be euthanized for debilitating conditions.¹³⁰

Attitudes about TNR were not the only barrier to animal shelters instituting TNR programs. Even when shelter managers were supportive of the theory of TNR, there were practical reasons why TNR for impounded feral cats could be difficult. Returning cats to the environment was antithetical to the animal control mission of a traditional shelter and was seen as abandonment. In some cases, ordinances or shelter policies prohibited such “abandonment.” Feral cats who were in a shelter were often there because they had been trapped and brought in by property owners who considered them a nuisance, and the cats had no safe place to go. Money was also a concern, since doing TNR in a shelter required sterilization and vaccinations that would have to be paid for by the shelter. And handling terrified feral cats safely and humanely required special procedures. These problems all had solutions that did not require killing the cats, but shelters had few resources for finding and implementing the solutions in the 1990s. As a result, relatively few public shelters did TNR in the 1990s.

¹²² “The Question of Feral Cats,” American Humane Association Advocate, 1996, 7; Scientific Workshop.

¹²³ “The Question of Feral Cats,” 7–8.

¹²⁴ *Ibid.*, 8.

¹²⁵ Esther Mechler, “Successful Strategies for Reducing Cat Overpopulation,” opening remarks, Public/Private Strategies for Cat Population Control Conference, Denver, CO, June 20–21, 1997.

¹²⁶ See, e.g., Peter Marra and Chris Santella, *Cat Wars: The Devastating Consequences of a Cuddly Killer* (Princeton: Princeton University Press, 2016); Loss, Will, and Marra, “The Impact of Free-Ranging Domestic Cats,” 2.

¹²⁷ Bradshaw, Casey, and Brown, *Behavior of the Domestic Cat*, 137–139; Patronek, “Special Report: Free-Roaming and Feral Cats,” 222.

¹²⁸ Bradshaw, Casey, and Brown, *Behavior of the Domestic Cat*, 137.

¹²⁹ See chapter 18.

¹³⁰ Jennifer Wallace and Julie Levy, “Population Characteristics of Feral Cats Admitted to Seven Trap-Neuter-Return Programs in the United States,” *Journal of Feline Medicine and Surgery* 8 (2006): 280, 282, doi:10.1016/j.jfms.2006.02.004.

In recent years, new management techniques based on the “community cat” concept have emerged that can be applied community-wide, including at the public shelter.¹³¹ This method defines unowned cats in a community, whether feral or tame, as “community cats.”¹³² Although community cats may not have owners in the traditional sense, they are part of the community and may be cared for by one or more individuals. Community cats can live healthy and happy lives even though they do not have traditional homes.

The community cat management approach includes a technique called “Return to Field” (RTF).¹³³ In an RTF program, a shelter sterilizes healthy, unidentified cats found outdoors and returns them to the location where they were found. If a cat is brought to the shelter as an owner surrender, or if it has identification such as a collar or microchip that allows the shelter to locate an owner, it is not generally a candidate for RTF. Instead of doing RTF in the shelter itself, some shelters divert RTF candidates to local organizations that do TNR. Because RTF reduces the average length of stay for healthy cats, it allows shelters to commit more resources to helping sick and injured cats.

In addition to being a good way to help community cats, RTF may also help lost and strayed cats who do not have identification. Reclaim rates for unidentified cats are quite low, with single digit reclaim rates typical for cats even at shelters that have good return-to-owner programs. This may be because many people allow their cats to roam outdoors and do not become alarmed if the cat disappears for a few days. By the time an owner decides to look for a strayed cat at the shelter, the cat may already have been adopted to another home or killed.¹³⁴ Although more studies would be useful, evidence so far indicates that owned cats who have strayed from home are far more likely to find their way home on their own than they are to be reclaimed if they are picked up by animal control and held at a shelter.¹³⁵ An RTF program, by returning cats to the locations where they were found, may give lost cats their best chance at being reunited with their families. And if a healthy outdoor cat has no owner, returning it to where it was found returns it to its sources of food and shelter.

The RTF concept works well as a shelter-management tool for community cats. It is supported by most of the animal-protection agencies that take an interest in free-roaming cats, and is rapidly being adopted by both traditional and No Kill shelters. It appears very possible that RTF will soon become the standard shelter protocol for healthy, unidentified cats found outdoors.

¹³¹ The Million Cat Challenge is a program that assists animal shelters in implementing community-cat management programs. “About the Million Cat Challenge,” *Million Cat Challenge*, accessed April 25, 2017, <http://millioncatchallenge.org/about/overview>.

¹³² Levy, email messages.

¹³³ These programs are sometimes called Shelter-Neuter-Return (SNR).

¹³⁴ Linda Lord et al., “Search and Identification Methods That Owners Use to Find a Lost Cat,” *Journal of the American Veterinary Medical Association* 230, no. 2 (January 15, 2007): 219, doi:10.2460/javma.230.2.217.

¹³⁵ *Ibid.*; Emily Weiss, Margaret Slater, and Linda Lord, “Frequency of Lost Dogs and Cats in the United States and the Methods Used to Locate Them,” *Animals* 2, no. 2 (June 13, 2012): 301–315, doi:10.3390/ani2020301.

Part V: No Kill Cities

Chapter 15: San Francisco: No Kill Programs

The San Francisco SPCA (SF/SPCA), a private organization founded in 1868, is one of the oldest SPCAs in the country.¹ Soon after it was founded, it began to receive calls to do something about cruelty at the city dog pound.² The pound drowned dogs in a tank,³ the same method used by the New York City pound during most of the latter half of the 19th century. John Partridge, an SF/SPCA member, led an effort in the 1880s to put the SF/SPCA in charge of animal control and sheltering for the city.⁴ In 1890, a petition from citizens persuaded the city to enlist the SF/SPCA's help in improving conditions at the city pound,⁵ and the SF/SPCA built a shelter that it called the "Animals Home" at 16th and Alabama streets.⁶

By 1905, the city of San Francisco and the SF/SPCA had formalized an arrangement that gave the SF/SPCA full responsibility for animal control in the city, an arrangement that would last for most of the 20th century.⁷ The SF/SPCA is still located on the 16th Street property where it built its first shelter, although it has bought adjoining property and greatly expanded its facilities over the years.



Figure 48:
Richard Avanzino with his dog, Bri. Courtesy of Maddie's Fund®.

The SF/SPCA operated as a traditional animal shelter until 1976, when the board hired Richard Avanzino as the organization's new president.⁸ Avanzino was an unusual choice to run an SPCA. He had a law degree and a doctorate in pharmacy, and in the years before he was hired by the SF/SPCA he had worked as a pharmacist, a lobbyist, and the associate director and legal counsel for a health planning group.⁹ He had no experience in animal control or sheltering.

One of the questions Avanzino was asked in the interview process at the SF/SPCA was how he felt about euthanasia. He was so unfamiliar with the procedures of animal sheltering that he thought they were asking him about "youth in Asia."¹⁰ The SF/SPCA was having problems at that time with financing and with persistent criticism from some animal activists, and perhaps the board of

¹ William Swallow, *Quality of Mercy: History of the Humane Movement in the United States* (Boston: Mary Mitchell Humane Fund, 1963), 22.

² *Ibid.*, 23.

³ "A Brutal Scene," *Oakland Daily Tribune*, July 27, 1874.

⁴ Sydney Coleman, *Humane Society Leaders in America* (Albany, NY: American Humane Association, 1924), 155–156. Partridge was elected president of the SF/SPCA in 1903.

⁵ Swallow, *Quality of Mercy*, 23.

⁶ "History," San Francisco SPCA, accessed March 20, 2017, <https://www.sfspca.org/who-we-are/history>.

⁷ *Ibid.*

⁸ Richard Avanzino, interviews by author, January 17, 2014, July 23, 2014, August 15, 2014, September 5, 2014, March 3, 2015, April 30, 2015, and February 4, 2016.

⁹ Avanzino, email messages to author, October 15, 2014, and February 11, 2016.

¹⁰ Avanzino, interviews.

directors wanted a person who could address those problems from a new perspective. Avanzino accepted the offer because he had always been a believer in animal welfare and he saw the job as an opportunity to do something meaningful on the issue.

Avanzino estimates that when he took over the SF/SPCA in 1976, it was saving only about 10% of the animals who came into the shelter, a typical save rate in those days for a shelter with responsibility for animal care and control. He made many changes in the first six months of his tenure to try to improve conditions and raise the number of animals released alive. The shelter was open from 11:00 a.m. to 4:00 p.m. four days a week before Avanzino took over, and he extended the hours to seven days a week.¹¹ He had the shelter painted to make it more welcoming to the public, and began to advertise.¹² He ordered the shutdown of the “decompression chamber” where animals were killed.¹³ Killing would be done by painless injection, the same method used by private veterinarians. He stopped the practice of killing female cats and dogs as a population control measure.¹⁴

Avanzino ordered all animals vaccinated on intake, which is routine today, but was not standard practice in 1976. He instituted a policy of refusing to kill an animal merely because an owner requested it. He added an infirmary to treat animals in the shelter, and created the city’s first low-cost spay-neuter clinic.¹⁵ The clinic would do more than 100,000 sterilization surgeries by the time Avanzino left the SF/SPCA.¹⁶ One of the most important innovations in 1976 was a volunteer program.¹⁷ The volunteers served as adoption counselors and ran a lost-and-found program.¹⁸ In 1978, Avanzino created the Hearing Dog Program, which recruited its dogs from Northern California shelters.¹⁹

A court case that started in 1979 transformed Avanzino’s thinking about sheltering and led him to adopt a new philosophy for the SF/SPCA. On December 21, 1979, the SF/SPCA received a call from the San Francisco police department to come get a dog whose owner had just died.²⁰ An animal control officer picked up the dog, whose name was Sido, and took her to the SF/SPCA shelter. As with all dogs where ownership could be at issue, Sido was placed in protective custody by the SF/SPCA.²¹

¹¹ Avanzino, email messages. The SF/SPCA also had evening hours. Avanzino’s recollection is that in the summer of 1976 they extended their hours until 7:00 p.m. on two weekdays. In 1977, they stayed open until 7:00 p.m. on four weekdays.

¹² Avanzino, interviews.

¹³ Avanzino, interviews; Mary Ippoliti-Smith, *The San Francisco Society for the Prevention of Cruelty to Animals: Historical Highlights Since 1976* (unpublished manuscript, 1998), 34.

¹⁴ Avanzino, interviews.

¹⁵ *Ibid.*; Ippoliti-Smith, *San Francisco Society for the Prevention of Cruelty to Animals*, 33.

¹⁶ Ippoliti-Smith, *San Francisco Society for the Prevention of Cruelty to Animals*, 2.

¹⁷ *Ibid.*, 33; Avanzino, interviews.

¹⁸ Ippoliti-Smith, *San Francisco Society for the Prevention of Cruelty to Animals*, 33.

¹⁹ *Ibid.*, 32.

²⁰ *In Re Estate of Mary Murphy*, Probate No. 225698, Superior Court of the State of California, City and County of San Francisco, Declaration of Richard Avanzino in Support of Instructions Preserving Sido’s Life, June 11, 1980, 1.

²¹ “The Will of the People,” *Our Animals*, Fall 1980, 4.

Sido was a Sheltie mix with an engaging personality. Her exact age was unknown, but she appeared to be about 10 years old. A dog of that age would not have been a likely candidate for adoption at most public shelters in those days. Shelters often had an age cutoff, typically around five years.²² If a dog was under the age cutoff and otherwise adoptable and the shelter had room, the dog could go up for adoption. If not, it was killed. The SF/SPCA, however, had a policy in 1979 to give every adoptable animal a chance to find a home.²³



Figure 49:
Sido, relaxing at home. Photograph courtesy of Richard Avanzino and the San Francisco SPCA.

Avanzino estimates that by 1979, the SF/SPCA was saving about 60% of dogs and that its save rate for dogs and cats combined was 40% to 50%.²⁴ The SF/SPCA did not kill animals solely because they were old, or female, or of a less popular size or breed. Nevertheless, many healthy and adoptable animals were killed because they did not find a home in their time on the adoption floor. Sido was a very appealing dog, though, so Avanzino and the SF/SPCA's shelter director, Carl Friedman, thought she had an excellent chance to be adopted despite her age.

On December 23rd, their plans for Sido went off the rails when the SF/SPCA received a call from the attorney handling the estate of Sido's owner. Sido's owner, fearing that harm would come to the dog after her death, had ordered in her will that Sido should be euthanized by her veterinarian. The attorney arrived at the SF/SPCA on December 28th to take Sido to be euthanized, but by that time Avanzino had decided, with the acquiescence of the SF/SPCA board, to fight the will. He refused to release Sido to the attorney and continued to hold her in protective custody.

For the next six months, Avanzino and the SF/SPCA were engaged in a fight to overturn the will's provision ordering Sido's death. The battle received international publicity. The final court hearing on June 17, 1980, was dramatic, with tension not only over how the judge would rule, but also over whether the California governor would sign a special bill that the legislature had passed to save Sido. The courtroom in San Francisco's historic City Hall was packed with reporters, and the hallway outside was full of photographers and television cameras.²⁵ In a media-pleasing denouement, both the governor and the judge decided in Sido's favor.²⁶ Avanzino had been fostering Sido, and he adopted her once the case was over.

During Sido's legal proceeding, the SF/SPCA received some 3,000 messages of support for her and hundreds of offers to adopt her.²⁷ Sido's team had carted many of the messages to the court for the final hearing on her case, as evidence for their argument that the provision of the will ordering Sido killed was

²² Avanzino, interviews.

²³ Ibid.; "The Will of the People," 4; Dexter Waugh, "SPCA Has the Will to Save Dog," *San Francisco Examiner*, January 17, 1980; Harriet Stix, "SPCA Battles to Save Life of Sido," *Los Angeles Times*, January 1980.

²⁴ Avanzino, interviews.

²⁵ "The Will of the People," 17.

²⁶ In Re Estate of Mary Murphy, Transcript of Proceedings, June 17, 1980; Carol Pogash, "Condemned Dog Set Free," *San Francisco Examiner*, June 17, 1980.

²⁷ William Carlsen, "The Dogfight Over a Will," *San Francisco Chronicle*, May 17, 1980; Associated Press, "A Plea for State to Spare Pet Dog," *San Francisco Examiner*, May 22, 1980; Carol Kroot, "Sido Gets New Leash on Life," *San Francisco Progress*, June 11, 1980.

invalid because it was against public policy. The judge agreed, concluding that the volume of messages was proof that “the public look[ed] with disfavor” on such testamentary provisions.²⁸



Figure 50:
Avanzino and Sido shaking hands, circa 1980. Photograph courtesy of
Richard Avanzino and the San Francisco SPCA.

Avanzino described the Sido victory as a sea-changing moment for him.²⁹ He realized that the public, far from having to be convinced to save shelter animals, was willing to take a lead role in lifesaving if shelters would make that possible. It was easy for animal shelter workers to develop a view of the public as a relentless wave that was constantly pounding them with neglected, abandoned, and unwanted animals.³⁰ The Sido case convinced Avanzino that although there were irresponsible people who abandoned or neglected their pets, there were far more people who were loving and responsible pet owners, and those people were willing to help shelters solve the problem of pet homelessness.

Avanzino’s epiphany resulted in his restructuring the SF/SPCA’s operations around the concept of trusting and reaching out to the public. He believed that people’s attitudes toward pets had evolved from a concept in the 1800s that pets were merely possessions to the idea of pets as best friends, and finally to the view of pets as family members.³¹ This led him to develop an approach that was more welcoming than that of the traditional animal shelter. His motto for the SF/SPCA was to do a good job, tell everyone about it, and ask for their help.³²

Avanzino gathered people around him who were open to this vision of how to run a shelter.³³ One of his most important hires was Lynn Spivak, whom he met while publicizing an early SF/SPCA program. In 1979, the SF/SPCA established a program called “Old Friendships” (later called “Pets and Older People”) that was designed to allow older people to acquire and keep pets.³⁴ It offered free adoptions to anyone over age 65, free temporary care if an older person had to be hospitalized, and free veterinary care for pets of low-income seniors.³⁵ In 1982, Avanzino appeared on a program on the local PBS station where he talked about the Pets and Older People program. Spivak, who was one of the program’s producers, was impressed with what Avanzino was doing at the shelter, and the following year she accepted the job of public information director for the SF/SPCA.³⁶ Like Avanzino, Spivak had no experience working for an animal shelter before coming to the SF/SPCA.

Avanzino gathered people around him who were open to this vision of how to run a shelter.³³ One of his most important hires was Lynn Spivak, whom he met while publicizing an early SF/SPCA program. In 1979, the SF/SPCA established a program called “Old Friendships” (later called “Pets and Older People”) that was designed to allow older people to acquire and keep pets.³⁴ It offered free adoptions to anyone over age 65, free temporary care if an older person had to be hospitalized, and free veterinary care for pets of low-income seniors.³⁵ In 1982, Avanzino appeared on a program on the local PBS station where he talked about the Pets and Older People program. Spivak, who was one of the program’s producers, was impressed with what Avanzino was doing at the shelter, and the following year she accepted the job of public information director for the SF/SPCA.³⁶ Like Avanzino, Spivak had no experience working for an animal shelter before coming to the SF/SPCA.

²⁸ In Re Estate of Mary Murphy, Transcript of Proceedings.

²⁹ Avanzino, interviews.

³⁰ Francis Battista, interview by author, September 22, 2014.

³¹ Avanzino, interviews.

³² Lynn Spivak, interview by author, February 4, 2014.

³³ Several people Avanzino hired went on to have leadership positions at other organizations. Mary Ippoliti-Smith, interview by author, January 20, 2016.

³⁴ Avanzino, interviews; Ippoliti-Smith, *San Francisco Society for the Prevention of Cruelty to Animals*, 32.

³⁵ Avanzino, interviews. The free-veterinary-care aspect of the program was initiated in 1977. Ippoliti-Smith, *San Francisco Society for the Prevention of Cruelty to Animals*, 33.

³⁶ Spivak, interview; Avanzino, interviews.

Traditional animal sheltering in the 1980s operated on the philosophy that killing a high percentage of the animals who came into shelters was acceptable because killing was a necessity, and a kindness for the animals.³⁷ This philosophy stemmed from the perception in the traditional shelter industry that there were not enough homes for the number of homeless pets, and that people were irresponsible and many of them would neglect their pets. As discussed in chapter 10, much progress had been made by the 1980s in reducing pet overpopulation, but intake numbers at most shelters in those years were still high. The result was that, as Spivak put it, “everything was really dire and serious” in the messaging from traditional shelters.³⁸

A common view in the traditional shelter industry in the 1980s was that if a shelter reached out to the public at all, it should emphasize pet overpopulation. Some shelters publicized the fact that the great majority of animals taken in at public shelters were killed. Spivak and Avanzino were in agreement that “we were not going to talk about . . . barrels of dead animals. All of our messaging was going to be positive and upbeat and get people excited about joining our cause and saving lives.”³⁹ Spivak pioneered the use of humor as a marketing strategy for an animal shelter. They did fun and sometimes even silly promotions.⁴⁰

One example of a fun event that received enthusiastic media attention was the SF/SPCA’s 1985 “Adopt-A-Stray” parade of homeless dogs down Market Street.⁴¹ Volunteers worked for days to prepare the animals. The parade featured a ragtime band and cartoon characters, and the city’s Chief of Protocol rode in the lead car. The idea was to find homes for some of the dogs who were getting overlooked by adopters. Of the 60 dogs in the parade, 20 were adopted before the day was over. The parade was so popular that it became an annual event.⁴²

Alex Lewyt of North Shore Animal League reached out to Avanzino after the Sido case and took an interest in the SF/SPCA’s operations. Avanzino visited North Shore twice and met Mike Arms, North Shore’s master of marketing.⁴³ Avanzino did not draw directly from the North Shore approach to adoptions, but its creativity and use of positive marketing messages impressed him and reinforced his ideas about reaching out to the public.

The SF/SPCA’s new approach of communicating with the public in a positive way was effective. As Avanzino said:

“When I left the San Francisco SPCA [at the end of 1998], we were getting 11 media stories a day, 365 days out of the year. I wrote myself for five newspapers and had my own radio talk show with KCBS, and we were on three TV stations every week, and then we had the news stories that came out in addition to all that stuff. So, we got a lot of coverage, and Lynn deserves the credit for getting the word out and telling the story and letting people know what the SF/SPCA was all about.”⁴⁴

Telling the public about the positive changes the SF/SPCA was making resulted in increased donations and more volunteers, which gave Avanzino the means for expanding programs at the shelter. Avanzino describes the process of program development as collaborative. Someone—Spivak or the shelter director

³⁷ See chapter 18.

³⁸ Spivak, interview.

³⁹ Ibid.

⁴⁰ Lynn Spivak, email message to author, February 17, 2016.

⁴¹ Gary Swan, “Dogs Hit the Road in Hopes of a Home,” *San Francisco Chronicle*, October 2, 1985.

⁴² Avanzino, interviews.

⁴³ Ibid. Avanzino is not sure of the dates of these visits but believes the first was in the late 1970s and the second in the early 1990s, after a new North Shore shelter building was opened in July of 1991.

⁴⁴ Ibid.

or an employee or a volunteer—would have an idea. Avanzino would ask the person to implement it, and the best ideas would then change and develop over time until they became full-fledged programs.

Volunteers were encouraged to participate in a wide range of functions.⁴⁵ They became a central part of SF/SPCA operations:

“[W]e benefitted not only from them caring for the animals, but they would go to work, or they would go back to their families, or they would be at their church and they would talk about the animals that they had been caring for over the previous week, and they became our salesmen, and they became our fundraisers, they became the heart and soul of the organization. . . . We had a very talented staff and a wonderful board of directors, but the volunteers are the ones I would give all the credit to for being so successful.”⁴⁶

The volunteer program was unstructured at first, and it had its problems. As Avanzino recalled:

“We started in a very unsophisticated, very organic, very creative environment. And as we got more knowledgeable and got lessons learned from our mistakes, we made improvements. But it never started out perfect. Nothing that we did ever started out being ideal. Everything had its setbacks, and its modifications, and had to be retooled, reinvented, rethought, and re-energized to make it successful.”⁴⁷

The SF/SPCA foster program, which started in 1980, grew out of the efforts of volunteers. At that time, the SF/SPCA did not have 24-hour animal care at the shelter. The foster program began with volunteers taking home infant animals who needed overnight feedings, animals who were stressed at the shelter, and animals who were sick or injured and were going to have to be housed for a substantial period of time.⁴⁸ Sometimes fosters adopted the animals they were fostering, or found homes for them.⁴⁹ They helped the program grow by recruiting additional fosters.

Offsite adoption was another early program that was powered by volunteers. The program started small, with volunteers taking animals out at lunchtime to their offices so that their coworkers could see them and hopefully be moved to adopt. From that beginning, it developed into a booth in front of an office building. By 1980, the SF/SPCA had a mobile adoption program.⁵⁰ This program, like the foster initiative, may have been the first such program in the nation.

Mobile adoptions were so successful that the SF/SPCA eventually ran a fleet of vans that could set up several adoption sites in the city in the morning, resupply them with animals during the day, and take down the equipment at night⁵¹. The program, called Adoption Outreach, was especially effective at finding homes for older and special needs cats.⁵² Offsite and mobile adoption programs are popular in the shelter industry today, but in the 1980s and 1990s, many shelter traditionalists rejected the idea because they saw it as equivalent to handing out pets on a street corner.⁵³

⁴⁵ *If You Love Animals . . . Volunteer* (San Francisco: San Francisco SPCA, n.d.).

⁴⁶ Avanzino, interviews.

⁴⁷ *Ibid.*

⁴⁸ *Ibid.*; Ippoliti-Smith, San Francisco Society for the Prevention of Cruelty to Animals, 32.

⁴⁹ Avanzino, interviews.

⁵⁰ *Ibid.*; Ippoliti-Smith, San Francisco Society for the Prevention of Cruelty to Animals, 31.

⁵¹ Avanzino, interviews.

⁵² Mike Rowell, “The Adoption Policies of the San Francisco SPCA,” *Latham Letter*, Winter 1991/1992, 21.

⁵³ Edwin Sayres, interview by author, March 7, 2014. Sayres noted that critics of mobile adoption ignored the fact that a shelter could use the same criteria for adoption at an offsite venue that it used at the shelter, and animals could be seen by more people at offsite locations.

The SF/SPCA developed an adoption matching procedure based on its experience with the Hearing Dog Program.⁵⁴ The process was designed to match the personality and needs of the pet with the personality and lifestyle of the owner.⁵⁵ A volunteer adoption counselor would talk with a person who was looking for a pet and help the person make a decision among the available pets.⁵⁶ The prospective adopter filled out a questionnaire, and an adoption counselor would speak in more depth to the adopter using the information from the questionnaire. The process was designed to be comprehensive and to make sure the adopter could provide a good home, but not to be intimidating. Each adopter was told that they could return the pet to the SF/SPCA at any time, but as of the early 1990s, only 4% of animals adopted from the SF/SPCA were returned.

SF/SPCA board members were enlisted in the creative effort to get animals adopted. One board member came up with the idea of featuring SF/SPCA animals in the holiday window displays at Gump's department store, a high-end retailer in San Francisco.⁵⁷ In 1987, the store dedicated prime display windows to SF/SPCA dogs and cats for the holidays.⁵⁸ Volunteers were in attendance to care for the animals, and a veterinarian and behaviorist were standing by.⁵⁹ The windows were so popular that people lined up to walk by and view them.⁶⁰

Gump's made the window displays an annual event, with a different theme each year. It expanded the holiday promotion to its stores in three other cities and helped 20 other department stores throughout the country that wanted to do similar promotions in 1988.⁶¹ The Gump's displays in San Francisco were responsible for about 250 adoptions per year.⁶² Various stores in San Francisco have hosted SF/SPCA animals over the years since then, and the holiday windows have become a tradition.

Another innovation was offering advice for pet owners about behavior problems. The SF/SPCA enlisted well-known animal behaviorist Ian Dunbar to develop a pet behavior program in 1983.⁶³ The program added a hotline in 1984, staffed by volunteers, called the Animal Behavior Advice Line.⁶⁴ The Advice Line received hundreds of calls per month, some from people who were considering giving up their pets due to behavior problems.⁶⁵ Behavior analysis and counseling became part of the SF/SPCA's comprehensive adoption package, launched in 1989, that also included preventive medical care.⁶⁶ This package was advertised on billboards throughout San Francisco and a brochure about it was mailed to every household in the city.⁶⁷

The behavior program evolved into a group of initiatives designed to reduce the number of owner surrenders by helping pet owners keep their pets. One of these initiatives was the 1991 Open Door

⁵⁴ Rowell, "Adoption Policies of the San Francisco SPCA," 21.

⁵⁵ *Ibid.*; *Adoption Pact 1995* (San Francisco: San Francisco SPCA, 1995), 7.

⁵⁶ Rowell, "Adoption Policies of the San Francisco SPCA," 21.

⁵⁷ Avanzino, interviews.

⁵⁸ Pat Steger, "Gump's Windows Are the Cat's Meow," *San Francisco Chronicle*, November 28, 1987; "History," *San Francisco SPCA*.

⁵⁹ Steger, "Gump's Windows Are the Cat's Meow."

⁶⁰ Avanzino, interviews.

⁶¹ Pat Steger, "Little Darlings, Again," *San Francisco Chronicle*, October 20, 1988.

⁶² Steve Rubenstein, "Cute Animals Gather at Gump's Again," *San Francisco Chronicle*, November 23, 1993.

⁶³ Avanzino, interviews; Ippoliti-Smith, "The San Francisco Society for the Prevention of Cruelty to Animals," 29. In 1997 the SF/SPCA created a Dog Behavior division, which oversaw the SF/SPCA's Canine Behavior Academy and Doggie Daycare Center. Ippoliti-Smith, *San Francisco Society for the Prevention of Cruelty to Animals*, 3.

⁶⁴ Ippoliti-Smith, *San Francisco Society for the Prevention of Cruelty to Animals*, 28; Avanzino, interviews; *If You Love Animals . . . Volunteer*, Sylvia Rubin, "Love and Death at the Pound," *San Francisco Chronicle*, February 4, 1988.

⁶⁵ "Advice Line is Behavior Program's Centerpiece," *Animal Sheltering*, November 1992. This item was reprinted in *Animal Sheltering* in the January-February 2004 issue.

⁶⁶ Ippoliti-Smith, *San Francisco Society for the Prevention of Cruelty to Animals*, 23.

⁶⁷ *Ibid.*, 22-23.

Campaign.⁶⁸ This program was aimed at helping people with pets find and keep rental housing, which was a major problem for pet owners in San Francisco.⁶⁹ The SF/SPCA provided brochures for landlords with suggested pet policies, and included statements from landlords who had successfully rented to people with pets.⁷⁰ They also provided a brochure for tenants with suggestions such as preparing a “pet resume.”⁷¹

Another program innovation was the institution of a waivable fee for owner surrenders.⁷² Avanzino was criticized for this because most people in animal sheltering at the time thought that putting any barriers in the way of people surrendering animals, even a small fee, would lead to people abandoning the animals in the street. And if animals were abandoned, rather than surrendered, it would be more expensive for the shelter, because free roaming animals picked up by animal control had to be held for a few days to allow their owners a chance to reclaim them. The number of animal control impounds did not increase after the surrender fee was adopted, however.

Low-cost and free spay-neuter programs were an important priority for Avanzino from the time he took over as president of the SF/SPCA. The SF/SPCA had an animal hospital that was built in 1924,⁷³ but there was no low-cost spay-neuter clinic until Avanzino opened one in late 1976.⁷⁴ The SF/SPCA could ill afford another project at that time, but Avanzino felt that the organization had to begin to offer the community more services before it could expect to increase its donations.⁷⁵ The spay-neuter clinic made it possible for the SF/SPCA to sterilize some animals before adoption, but it would not be until 1989 that the SF/SPCA was able to spay and neuter every animal before it left the shelter.⁷⁶

The SF/SPCA was an early adopter of pediatric spay-neuter, where puppies and kittens are sterilized at eight weeks of age, rather than the traditional minimum age of six months.⁷⁷ This was an important innovation, because even when people were required to pay the full price of a future spay or neuter surgery before adopting a puppy or kitten, they often failed to bring the animal back for the surgery. Sterilizing puppies and kittens before they left the shelter was an essential part of reducing breeding and thereby reducing future shelter intake.

The SF/SPCA was also an early adopter of feral cat programs. Shortly after Avanzino took over as president, he stopped the practice of providing traps to people to catch feral cats and bring them to the SF/SPCA to be killed.⁷⁸ The next step was to refuse to take in feral cats that people had trapped on their own. Animal control officers would respond to calls about nuisance feral cats, but since animal control officers did not do trapping, they were not very successful at catching feral cats. These early steps to stop the killing of feral cats were a big part of the decline in shelter killing that Avanzino was able to achieve in his first six months at the SF/SPCA.

The SF/SPCA worked with feral cat caregivers in 1992 to successfully oppose a city catch-and-kill proposal.⁷⁹ In 1993, the SF/SPCA began to take a much more active role for feral cats by implementing its

⁶⁸ Ibid., 19–20.

⁶⁹ Emerald Yeh and Christine McMurry, “A Tough Town for Renters with Pets,” *San Francisco Chronicle*, October 6, 1996.

⁷⁰ *A Property Owner’s Guide* (San Francisco: San Francisco SPCA, 1993).

⁷¹ *A Tenant’s Guide* (San Francisco: San Francisco SPCA, 1993); Yeh and McMurry, “A Tough Town for Renters with Pets.”

⁷² Avanzino, interviews.

⁷³ Joseph Arburua, *Narrative of the Veterinary Profession in California* (San Francisco: Joseph Arburua, 1966), 239.

⁷⁴ “History,” *San Francisco SPCA*; Avanzino, interviews.

⁷⁵ Avanzino, interviews.

⁷⁶ Ibid.

⁷⁷ Ippoliti-Smith, *San Francisco Society for the Prevention of Cruelty to Animals*, 23; Avanzino, interviews.

⁷⁸ Avanzino, interviews.

⁷⁹ Ippoliti-Smith, *San Francisco Society for the Prevention of Cruelty to Animals*, 20.

Feral Fix trap-neuter-return (TNR) program.⁸⁰ Under the Feral Fix program, caregivers could trap cats and bring them in for free health screening, sterilization and vaccinations.⁸¹ The caregivers received a small cash bonus for each cat brought in.⁸² Friendly cats who were healthy could go directly into the SF/SPCA's adoption program,⁸³ and a foster program for feral kittens socialized them for adoption.⁸⁴ TNR was offered on a limited schedule at first, but by 1995, it was available daily with no appointment required.⁸⁵ San Francisco SPCA community organizer, Leslie Wilson, coordinated the program's outreach.⁸⁶

Feral Fix eventually developed into a full suite of services called the Feral Cat Assistance Program. The program included workshops for feral cat caregivers on medical problems, caring for neonatal kittens, and relocating cats.⁸⁷ Volunteer "Cat Assistance Teams" helped people with trapping and other feral cat issues.⁸⁸ By 1998, the program was sterilizing 1,100 feral cats per year.⁸⁹ In 2001, Wilson reported that the number of cats impounded in the city had dropped by 28% and cat euthanasia had dropped 73% "thanks in large part" to the Feral Cat Assistance Program.⁹⁰

The SF/SPCA developed many other programs and initiatives during Avanzino's tenure, most of which were not practiced by traditional shelters. Mary Ippoliti-Smith, who worked in development at the SF/SPCA, made a list of program and initiative highlights from 1976 to 1998. The list is 34 pages long and contains hundreds of items.⁹¹ The SF/SPCA's work was not limited to shelter animals. It challenged the cruel treatment of food animals at a city market, inspected laboratories for compliance with the Animal Welfare Act, lobbied for animal friendly legislation, and worked to protect wildlife.⁹²

The SF/SPCA programs that were created in the years from 1976 to 1998 were a crucial part of reducing shelter killing in San Francisco, but the programs were only the first phase in developing a comprehensive safety net for pets in the city. The next chapter discusses the second phase of development, reconfiguring how the city did animal care and control.

⁸⁰ John Black, "Feral Fix Works Wonders," *Our Animals*, Summer 1996, 7.

⁸¹ *Feral Cat Assistance Program* (San Francisco: San Francisco SPCA, n.d.); Avanzino, interviews; Ippoliti-Smith, *San Francisco Society for the Prevention of Cruelty to Animals*, 16. The SF/SPCA would also sterilize tame cats that people found outdoors and return them to the person who had brought them in. Avanzino, interviews.

⁸² *Feral Cat Assistance Program*; Avanzino, interviews. In 1995 the cash-reward program was extended to owners who brought in pet cats for free sterilization. *Adoption Pact 1995*, 4.

⁸³ Black, "Feral Fix Works Wonders," 10, 13.

⁸⁴ Glen Martin, "Solution to the Feline Explosion," *San Francisco Chronicle*, June 19, 1993.

⁸⁵ *Feral Cat Assistance Program*; Black, "Feral Fix Works Wonders," 8; *Building A No-Kill City* (San Francisco: San Francisco SPCA, 1996), 4.

⁸⁶ Black, "Feral Fix Works Wonders," 9.

⁸⁷ *Feral Cat Assistance Program*.

⁸⁸ *Ibid.*

⁸⁹ Glen Martin, "Penthouse for Pets," *San Francisco Chronicle*, April 14, 1998. Feral Fix treated 1055 cats in 1997. Ippoliti-Smith, *San Francisco Society for the Prevention of Cruelty to Animals*, 4.

⁹⁰ Leslie Wilson, "How to Start a Feral Cat Program," *Maddie's Fund*, last modified 2001, accessed March 20, 2017, <http://www.maddiesfund.org/how-to-start-a-feral-cat-program.htm?p=topic37>.

⁹¹ Ippoliti-Smith, *San Francisco Society for the Prevention of Cruelty to Animals*.

⁹² *Ibid.*

Chapter 16: San Francisco: No Kill Model

As described in the previous chapter, Richard Avanzino made extensive changes in the programs of the San Francisco SPCA (SF/SPCA) after he took over as president in 1976, with the goals of cutting intake and increasing live placements.¹ But by the mid-1980s, Avanzino realized that changes to SF/SPCA programs would not be enough. Creating a sustainable model of lifesaving for homeless pets in San Francisco would require a restructuring of the relationship between the SF/SPCA and the city.

At the time Avanzino was hired by the SF/SPCA board in 1976, the city government and many citizens were unhappy with the job the SF/SPCA was doing under its contract with the city for animal care and control. In fact, Avanzino faced a crisis in his first few days at work when the city threatened to cancel the contract.² Avanzino was able to improve the SF/SPCA's performance, but continued to struggle with a lack of adequate funding under the contract.³ Avanzino felt that the SF/SPCA was being forced to subsidize animal care and control with donations from the public, and this was preventing it from properly funding its own initiatives such as low-cost sterilization and veterinary care for treatable animals.⁴ The city, however, wanted the SF/SPCA to make animal control its priority.⁵

By 1984, when the city faced a particularly serious budget crisis, the situation had become untenable. During negotiations between the SF/SPCA and the city over the contract that year, the SF/SPCA asked the city to draw up a contingency plan for handling animal control and sheltering if, in the future, the SF/SPCA decided not to bid on the contract.⁶ The city took no immediate action to prepare such a plan.⁷ To make matters worse, a vocal private citizen went public in 1986 with allegations that the SF/SPCA was receiving a higher per capita rate of funding than public shelters in other cities.⁸

In addition to the funding issue, there was a clash between Avanzino's vision for the SF/SPCA and the functions of animal control.⁹ Avanzino felt that it was ethically wrong for an organization dedicated to animal welfare to be in the business of killing animals.¹⁰ He also believed that the SF/SPCA's role in shelter killing made it harder for the SF/SPCA to attract the trust and support it needed from the public. As he put it: "[I]f you asked the people of San Francisco in the 1980s, what is the first thing you think of when you think of the San Francisco SPCA, the feeling was, that's where the animals die, that's where they kill the animals."¹¹

All these issues came to a head in 1987, when the SF/SPCA asked the city for an 11% increase in funding for the fiscal year starting in 1988. Negotiations between the SF/SPCA and the city deadlocked, and two members of the city's Board of Supervisors requested an audit of the SF/SPCA.¹² A month later, the parties

¹ Richard Avanzino, interviews by author, January 17, 2014, July 23, 2014, August 15, 2014, September 5, 2014, March 3, 2015, April 30, 2015, and February 4, 2016.

² Ibid.

³ Richard Avanzino, "San Francisco: The Nation's First Adoption Guarantee City" (2000), *Maddie's Fund: Evolution of the No Kill Movement*, accessed March 20, 2017, <http://www.maddiesfund.org/san-francisco-the-nations-first-adoption-guarantee-city.htm?p=topic37>.

⁴ Ibid.; Avanzino, interviews.

⁵ Avanzino, interviews.

⁶ Avanzino, "San Francisco: The Nation's First Adoption Guarantee City"; Avanzino, interviews.

⁷ Avanzino, interviews.

⁸ Jack Viets, "SPCA Critic Says S. F. Paying Top Dollar for Animal Control," *San Francisco Chronicle*, August 5, 1986.

⁹ Avanzino, "San Francisco: The Nation's First Adoption Guarantee City."

¹⁰ Avanzino, interviews.

¹¹ Ibid.

¹² J. H. Doyle, "Historic SPCA Pact Periled," *San Francisco Chronicle*, March 18, 1987; J. H. Doyle, "S. F. Supervisors Request SPCA Audit," *San Francisco Chronicle*, March 26, 1987.

agreed on a plan to grant the SF/SPCA most of the increase it had requested.¹³ Then, in late 1987, bruised by the constant battles, the SF/SPCA notified the city that it would not bid on the contract for the fiscal year beginning in 1989.¹⁴

Even with the funding problems, giving up the contract was a wrenching change for members of the SF/SPCA board of directors.¹⁵ The SF/SPCA had been involved in animal control and sheltering in San Francisco for almost a century, and the board was hesitant to terminate that long relationship. They also worried that the city would not do a good job of protecting homeless animals.¹⁶ Ultimately, the board agreed to give up the contract, but three members resigned over the issue.¹⁷

As it turned out, the transition to a new system went very well.¹⁸ The city had no shelter or animal control program of its own, so it had to build a shelter and hire staff to run it.¹⁹ In 1988, the city selected Carl Friedman to be the director of the new city shelter and to manage the transition process.²⁰ Friedman had been involved with pet welfare in San Francisco since the early 1970s, when he rescued a puppy from the street and then realized there was no good system for reuniting lost pets with their owners.²¹ This experience led him and his wife to form a 24-hour lost-and-found switchboard. They operated the service independently for three years, receiving 50 to 60 calls per day. Friedman moved the lost-and-found service to the SF/SPCA after Avanzino became president in 1976, and continued to run the program as a volunteer.

Within a year, the SF/SPCA offered Friedman a paid position as assistant volunteer coordinator, and later promoted him to director of animal control and welfare for the SF/SPCA.²² He was the shelter director in 1979 at the time of the Sido case (see chapter 15), and he was the person who brought Sido's plight to Avanzino's attention. Friedman left the SF/SPCA after working closely with Avanzino for several years, but remained involved in animal welfare issues as a member of the city's Commission of Animal Control and Welfare.²³ Avanzino described Friedman as "hugely important to the San Francisco SPCA and to me in terms of developing lifesaving programs," and described himself as "thrilled" when he heard that Friedman had been selected as the head of the new city shelter.²⁴ He said the city "could not have made a better choice."²⁵

Friedman and other city officials, including representatives of the police and health departments, worked closely with the SF/SPCA to set up the new city agency and make sure it would be adequately funded.²⁶ The city budgeted \$2.7 million to renovate a warehouse across the street from the SF/SPCA to serve as the new shelter, and hired a workforce of about 30 people.²⁷ Many of them came from the SF/SPCA, with

¹³ "SPCA Still the Official Dogcatcher," *San Francisco Chronicle*, April 22, 1987.

¹⁴ Avanzino, interviews; Carl Friedman, "Farewell After 20 Years of Service to Animals and the Community," *Tails of the City: The Newsletter of the San Francisco Department of Animal Care and Control*, Fall-Winter 2009, 5.

¹⁵ Avanzino, interviews.

¹⁶ Avanzino, "San Francisco: The Nation's First Adoption Guarantee City."

¹⁷ Avanzino, interviews.

¹⁸ Avanzino, "San Francisco: The Nation's First Adoption Guarantee City."

¹⁹ Martha Armstrong, Susan Tomasello, and Christyna Hunter, "From Pets to Companion Animals," in *The State of the Animals: 2001*, ed. Deborah Salem and Andrew Rowan (Washington, DC: Humane Society Press, 2001), 77.

²⁰ Friedman, "Farewell," 5.

²¹ *Ibid.*, 4.

²² *Ibid.*; Avanzino, interviews.

²³ Friedman, "Farewell," 4–5; Avanzino, "San Francisco: The Nation's First Adoption Guarantee City."

²⁴ Avanzino, interviews.

²⁵ *Ibid.*

²⁶ *Ibid.*; Bert Troughton, "Reaching Your Dreams," *Best Friends Animal Society No More Homeless Pets Forum*, December 8, 2003, Internet Archive, <https://web.archive.org/web/20061206085049/http://www.bestfriends.org/archives/forums/dreams.html>.

²⁷ Jim Doyle, "SPCA Upset: S. F. to Run Shelter For Stray Dogs, Cats," *San Francisco Chronicle*, January 12, 1989.

Avanzino's blessing.²⁸ He felt it would help the new agency perform better and help the two organizations work together seamlessly if the staff of the city agency was well supplied with people who had been trained at the SF/SPCA.

The new agency was named the San Francisco Department of Animal Care and Control (SF/ACC), and it was a full-service shelter. Its first day of operations was July 1, 1989.²⁹ More than 200 animals came in that day.³⁰ With the opening of the SF/ACC facility, kennel space for shelter animals in the city was doubled and total staffing for animal control and sheltering was substantially increased.³¹ The SF/ACC was an independent agency within the city government, which meant that Friedman was a department head.³² In most cities, the animal shelter falls under the jurisdiction of the police or health department, but Friedman was able to make his case for funding and other resources directly to city leaders.³³



*Figure 51:
The SF/SPCA was a pioneer in giving orphaned kittens the same chance for adoption as kittens raised by their mothers. Photograph by Wouter Hagens, licensed under CC BY-SA 3.0.*

After the SF/ACC was up and running, Avanzino was able to reinvent the SF/SPCA's role in the community.³⁴ The SF/SPCA finally had the resources to treat all of its treatable animals and find homes for all of its healthy and treatable animals, including the ones it took from SF/ACC. The SF/SPCA made use of its freed-up resources to enlarge several of its existing programs, including Adoption Outreach and the foster and volunteer programs.³⁵ One item that was high on the SF/SPCA's new agenda was a major spay-neuter campaign designed to bring down the number of homeless animals in the city by providing more low-cost and free sterilizations.³⁶ Another project was expansion of medical and rehabilitation services.³⁷

Motherless kittens were an important category of treatable animals. In 1976, when Avanzino first started with the SF/SPCA, kittens who came in with their mothers were given a chance for adoption. But motherless kittens who were too young for adoption were killed on intake.³⁸ These "neonatal" motherless kittens, often just a few days old, needed around-the-clock care and housing away from other animals to survive. After the SF/SPCA gave up the city contract, it had the resources to set up a neonatal kitten program. The program was a major success, and in 1995, over 1,000 underage kittens were treated, held until they were

²⁸ Avanzino, interviews; Avanzino, "San Francisco: The Nation's First Adoption Guarantee City."

²⁹ Friedman, "Farewell," 5.

³⁰ Ibid.

³¹ "New SPCA Role," editorial, *San Francisco Chronicle*, July 3, 1989.

³² Troughton, "Reaching Your Dreams."

³³ Ibid.

³⁴ Avanzino, interviews.

³⁵ Avanzino, "San Francisco: The Nation's First Adoption Guarantee City."

³⁶ Troughton, "Reaching Your Dreams."

³⁷ Avanzino, "San Francisco: The Nation's First Adoption Guarantee City." In 1995 the SF/SPCA completed construction of the PeopleSoft Pet Recovery Center on an adjoining property, consolidating the SF/SPCA's medical and rehabilitation services in one location. Mary Ippoliti-Smith, *The San Francisco Society for the Prevention of Cruelty to Animals: Historical Highlights Since 1976* (unpublished manuscript, 1998), 11–12, 14.

³⁸ Avanzino, interviews.

old enough to be adopted, sterilized, and adopted into homes.³⁹ About 80% of the work to save these kittens was done by volunteers.⁴⁰

Meanwhile, as the SF/SPCA was improving its resources for helping treatable animals, Avanzino was developing a plan to guarantee every healthy animal in the city a home.⁴¹ He did not broach this idea for the first couple of years after the SF/ACC was created because he wanted to give the city time to stabilize the new department.⁴² But in 1992, with the SF/ACC functioning well and the SF/SPCA expanding its programs, the SF/SPCA Board of Directors formally adopted a goal of setting up a system to find homes for all adoptable animals in the city.⁴³

The SF/SPCA plan that emerged from this goal was very simple. Avanzino wanted the city to agree to a joint public announcement that the SF/ACC and the SF/SPCA, working together, would guarantee the adoption of every healthy dog and cat in the system who needed placement.⁴⁴ Avanzino believed that if people were confident that the SF/ACC and the SF/SPCA would find every healthy pet a new home, they would be less likely to abandon pets in the street where they might get hit by cars or produce more homeless pets.⁴⁵ He believed that healthy animals who were surrendered by their owners would be much easier to place than sick, injured, or frightened strays found outdoors.

City officials were less than enthusiastic, fearing that if every healthy animal was guaranteed a home, people would be more likely to surrender their pets to the SF/ACC for trivial reasons and intake would increase.⁴⁶ They also feared that an adoption guarantee would send a message to the public that pet overpopulation was no longer a problem, resulting in people being less likely to spay and neuter their pets. In September 1993, after the city failed to act on the SF/SPCA's request for an adoption guarantee agreement, Avanzino announced that the SF/SPCA would propose a city ordinance that would require the SF/ACC to transfer adoptable animals to the SF/SPCA when the SF/ACC could not find homes for them.⁴⁷ Avanzino called this proposed ordinance the Adoption Act. The SF/SPCA promised to spend \$1 million to house and adopt out transferred animals in 1994 if the ordinance was enacted.⁴⁸

Before the Adoption Act could go to the city's Board of Supervisors for consideration, Avanzino had to present it to the city's Commission of Animal Control and Welfare.⁴⁹ The SF/ACC, the California Animal Control Directors Association, and four large animal shelters in the Bay area were among those who opposed the measure. Avanzino told the Commission that he would seek a public referendum on the issue if a satisfactory agreement could not be reached.⁵⁰ The chairperson of the Commission then asked the SF/SPCA and the SF/ACC to try to work out an agreement for voluntary cooperation.⁵¹

³⁹ *Adoption Pact 1995* (San Francisco: San Francisco SPCA, 1995), 6.

⁴⁰ Avanzino, interviews.

⁴¹ *Ibid.*

⁴² *Ibid.* The city was also dealing with the effects of the 1989 Loma Prieta earthquake.

⁴³ *Building A No-Kill City* (San Francisco: San Francisco SPCA, 1996), 2; Avanzino, interviews.

⁴⁴ Avanzino, interviews.

⁴⁵ Avanzino, "San Francisco: The Nation's First Adoption Guarantee City"; "Bid to Save Strays from Destruction," *San Francisco Chronicle*, September 17, 1993.

⁴⁶ Avanzino, "San Francisco: The Nation's First Adoption Guarantee City."

⁴⁷ "Bid to Save Strays from Destruction." Around this time the SF/SPCA launched the "Animals Deserve Our Protection Today" initiative, called ADOPTION, to guarantee a home for all adoptable pets in the city. Ippoliti-Smith, *San Francisco Society for the Prevention of Cruelty to Animals*, 17.

⁴⁸ *Ibid.*

⁴⁹ Avanzino, "San Francisco: The Nation's First Adoption Guarantee City"; "Bid to Save Strays From Destruction."

⁵⁰ Avanzino, interviews.

⁵¹ Avanzino, "San Francisco: The Nation's First Adoption Guarantee City."



Figure 52:
SF/SPCA brochure describing the historic Adoption Pact. From the author's collection.

Avanzino and Friedman worked together with a facilitator for months to hammer out the agreement that became known as the Adoption Pact.⁵² As the details of the Pact were worked out, Avanzino and Pam Rockwell drafted its text.⁵³ Rockwell, a graduate of Yale Law School, was the director of the SF/SPCA's Ethical Studies department, and she drafted many of the SF/SPCA's important documents.⁵⁴ The Adoption Pact was finally signed by Avanzino and Friedman on April 1, 1994.⁵⁵ Either agency could revoke the entire agreement at any time by written notice,⁵⁶ but at the time of this writing, 22 years after its signing, the Adoption Pact is still in effect in San Francisco.⁵⁷

The Adoption Pact is a straightforward and relatively short document. It classifies animals coming into the SF/ACC into three categories: "adoptable," "treatable," and "non-rehabilitatable." The heart of the Pact is that the SF/ACC guarantees that it will not euthanize any adoptable dog or cat, and if it is not able to place an adoptable dog or cat through its own adoption program, it will transfer the animal to the SF/SPCA, which guarantees to take it and find a suitable adoptive home for it.⁵⁸

The SF/ACC was given the power to define "adoptable," "treatable," and "non-rehabilitatable" for purposes of the Pact.⁵⁹ Guidelines for the Pact state that "adoptable" is understood to mean an animal who has shown no sign of a health or temperament problem.⁶⁰ Notably, this definition of "adoptable" does not exclude animals based on age, breed, or appearance. Health and temperament are the only criteria for exclusion.

The Adoption Pact provides that, in addition to saving all adoptable animals, the SF/ACC and the SF/SPCA "shall work together towards ending the euthanasia of 'treatable' cats and dogs."⁶¹ The guidelines in the Pact state that the "treatable" category is understood to include cats and dogs who could become adoptable

⁵² Avanzino, interviews.

⁵³ *Ibid.*

⁵⁴ *Ibid.*

⁵⁵ Avanzino, "San Francisco: The Nation's First Adoption Guarantee City"; "Agreement Between the San Francisco Society for the Prevention of Cruelty to Animals and the San Francisco Department of Animal Care and Control," April 1, 1994.

⁵⁶ "Agreement," section 6.

⁵⁷ Jennifer Scarlett and Jason Walthall, interview by author, February 9, 2016.

⁵⁸ "Agreement," sections 1.1 and 1.2.

⁵⁹ *Ibid.*, section 3.2.

⁶⁰ *Ibid.*, section 3.2.1.

⁶¹ *Ibid.*, section 2.1.

“with reasonable efforts.”⁶² The SF/ACC is required to turn over to the SF/SPCA any treatable cat or dog that the SF/SPCA requests, but there is no requirement that the SF/SPCA take a “treatable” animal.

The Adoption Pact was an agreement between the city and the SF/SPCA, but Avanzino saw it in a broader sense as a promise made by the SF/SPCA to the community that all healthy and temperamentally sound cats and dogs who entered the animal control and sheltering system would be saved.⁶³ In addition to pushing the Adoption Pact through, the SF/SPCA put this idea of a trusting relationship with the community into effect by opposing mandatory policies as to impoundment, fines, spay-neuter, and cat licensing.⁶⁴ The SF/SPCA took the position that it should focus on “what we, as a shelter, can do to help—not punish—the community.”⁶⁵

The community responded positively to the new approach. The SF/SPCA had 27,000 contributors in 1988, before giving up the animal control contract.⁶⁶ That number grew to 57,760 in 1994, the year the Pact was signed, and to 70,991 the following year.⁶⁷ The number of contributors reached 90,000 by the end of the decade.⁶⁸ The number of volunteers grew from 601 in 1988 to over 2,300 people who donated over 80,000 hours per year by 1995.⁶⁹

In the first year after the Adoption Pact went into effect, the SF/ACC and SF/SPCA achieved the goal of ending the killing of adoptable cats and dogs.⁷⁰ And from the early days of the Pact, the SF/SPCA took in many treatable animals along with the adoptable ones. In the first year after the Pact was signed, the SF/SPCA reported that it had found homes for 5,054 cats and dogs, including 3,382 treatable animals.⁷¹ The SF/ACC killed 1,185 treatable animals during the first year of the Adoption Pact, down from 2,494 the year before.⁷² “Non-rehabilitatable” animals were defined in the Adoption Pact as those who were a danger to the public or for whom euthanasia was “the most humane alternative” due to disease or injury.⁷³ In the Adoption Pact’s first year, 74% of the animals killed at the SF/ACC were classified as non-rehabilitatable.⁷⁴

The term “No Kill” was very controversial in the 1990s, and that led the SF/SPCA to initially use the term “adoption guarantee” for the concept that no adoptable cat or dog should die for lack of a home. “Adoption guarantee” did not prove to be less inflammatory, though, so in the mid-1990s the SF/SPCA began to refer to itself as a “No Kill” organization.⁷⁵

⁶² *Ibid.*, section 3.2.2. A dispute arose over the SF/ACC’s classification of some dogs as “adoptable” that the SF/SPCA classified as “non-rehabilitatable” on the issue of whether the SF/ACC had documented that the dogs had temperaments suitable for adoption. These cases were footnoted in joint statistical reports.

⁶³ Adoption Pact 1995, 5.

⁶⁴ Avanzino, interviews.

⁶⁵ Adoption Pact 1995, 7.

⁶⁶ Avanzino, “San Francisco: The Nation’s First Adoption Guarantee City.” The SF/SPCA by-laws did not recognize a membership category, but the SF/SPCA designated its contributors as “members.” Avanzino, interviews.

⁶⁷ Adoption Pact 1995, 13.

⁶⁸ Avanzino, “San Francisco: The Nation’s First Adoption Guarantee City.”

⁶⁹ *Ibid.*; Adoption Pact 1995, 13.

⁷⁰ Adoption Pact 1995, 1; “San Francisco SPCA Celebrates Adoption Pact’s Successful First Year!,” *Latham Letter* 16, no. 4 (1995): 12.

⁷¹ Adoption Pact 1995, 1–2. Of the treatable animals placed by the SF/SPCA, 1,741 came from the SF/ACC, 1,242 were owner surrenders, and 399 came from other area shelters and rescue groups. Adoption Pact 1995, 6.

⁷² *Ibid.*, 8. The SF/ACC returned 1,388 animals to their owners in the first year after the Adoption Pact was signed, found adoptive homes for 2,138, and transferred 2,219 to the SF/SPCA. The SF/ACC euthanized 3,403 non-rehabilitatable animals and the SF/SPCA 157.

⁷³ “Agreement,” section 3.2.3.

⁷⁴ Adoption Pact 1995, 3.

⁷⁵ Avanzino, “San Francisco: The Nation’s First Adoption Guarantee City”; Avanzino, interviews.

By 1995, Avanzino was ready to take the concept of a No Kill city to the national stage. He spoke at the first national No Kill conference in 1995.⁷⁶ In 1996, he instituted a quarterly training seminar at the SF/SPCA called Mission Possible.⁷⁷ A 1996 pamphlet called “Building A No Kill City,” prepared for an American Humane Association (AHA) leadership forum, contained Avanzino’s most complete statement to date of how to create No Kill in a community.⁷⁸ The pamphlet set out the “building blocks” of San Francisco’s success as including, among other things, spay-neuter programs, the Feral Fix initiative, support for owners to keep animals in their homes, adoptions, foster care, and media outreach, with all of it aided by volunteers.⁷⁹ The pamphlet also said: “Most of all . . . it is a story about believing in the community and trusting in the power of compassion.”⁸⁰

In an article in the SF/SPCA’s magazine, Avanzino expounded on the concept that the entire United States could become No Kill: “Every community has the power to achieve what San Francisco has achieved. And, working together, we have the power to build an entire No Kill Nation. . . . Each community must decide for itself what steps it needs to take and how to build its path. By sharing our successes and failures, we can help each other learn, but no single philosophy or program can provide a substitute for the energy and excitement that comes from our own hometowns.”⁸¹

In 1998, as part of its ongoing effort to increase adoptions, the SF/SPCA built the Maddie’s Pet Adoption Center next to its original shelter.⁸² The adoption floor of this building featured individual spaces for cats and dogs set up like rooms in a home, without cages. A news feature on the grand opening of the Pet Adoption Center noted the upholstered furniture, beam ceilings, original artwork, skylights, and strolling violinist, and remarked that daycare facilities for children were not nearly as inviting.⁸³ Prospective adopters could wander down aisles with names like “Lassie Lane,” viewing the dogs and cats through large windows.⁸⁴ They could get to know a potential pet in the solarium, the rumpus room, the veranda, or the gymnasium.⁸⁵ Lemonade and cappuccino were served in the lobby.⁸⁶

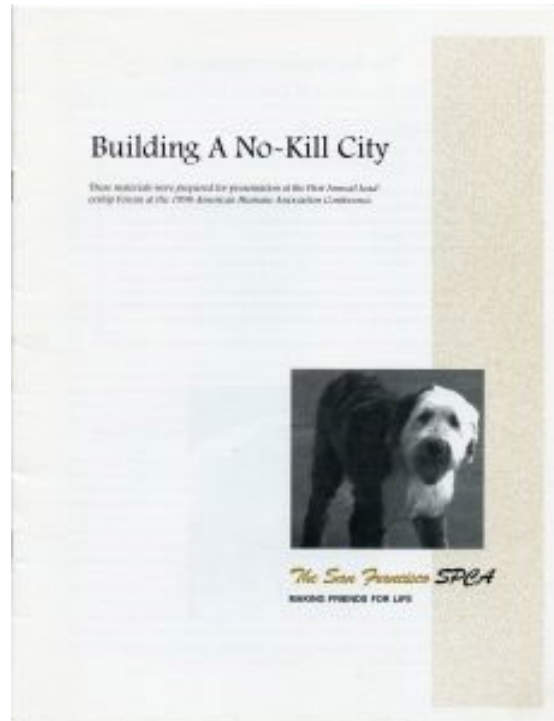

Figure 53:
Avanzino’s 1996 “Building A No Kill City” brochure was a landmark document in the origin of No Kill. From the author’s collection.

⁷⁶ Merritt Clifton, “What’s in a Name? No-Kills and the Heart of Darkness,” *Animal People*, April 1997, 15.

⁷⁷ Avanzino, interviews.

⁷⁸ Building A No-Kill City; Ippoliti-Smith, San Francisco Society for the Prevention of Cruelty to Animals, 6.

⁷⁹ Building A No-Kill City, 4–5.

⁸⁰ *Ibid.*, 1.

⁸¹ Richard Avanzino, “Building A No-Kill City,” *Our Animals*, Winter 1996–1997, 5.

⁸² Steve Rubenstein, “Living Large at Comfy S. F. SPCA,” *San Francisco Chronicle*, February 5, 1998; Avanzino, interviews.

⁸³ Rubenstein, “Living Large.”

⁸⁴ David Key, “Case Study, 21st Century Dog Apartments,” in *Kennel Design: The Essential Guide to Creating Your Perfect Kennels* (Oxfordshire, UK: David Key, 2008), 158–162.

⁸⁵ Rubenstein, “Living Large.”

⁸⁶ Glen Martin, “Penthouse for Pets,” *San Francisco Chronicle*, April 14, 1998.

The Maddie's Pet Adoption Center was designed to accustom animals to living in a home and to give potential adopters a better idea of how a particular animal would fit into their own home.⁸⁷ Although some people felt at the time that the Pet Adoption Center was excessive in the accommodations it made for animals, it foreshadowed a trend in shelter buildings today to make the adoption process as easy and appealing as possible and to create housing for animals that encourages positive behaviors and provides a good quality of life.

A shelter reform law enacted by the state of California in 1998, the Hayden Law, is worthy of note because it contained provisions that were designed to increase the number of animals released alive from shelters. Its effect has been hard to quantify. Taimie Bryant, a professor of law at the University of California, observed that it was difficult to measure the effect of the legislation because the No Kill movement (see chapter 20) was already in existence when the law was enacted.⁸⁸ Suspension of some provisions of the law, funding issues, and threats of repeal have caused further problems with measuring its effect.⁸⁹ If nothing else though, the Hayden Law put animal shelters in California on notice that their performance was a matter of legislative concern.

Avanzino left the SF/SPCA at the end of 1998 to become the president of Maddie's Fund.⁹⁰ He had been president of the SF/SPCA for 22 years, during which time its annual budget had grown from \$22,000.00 to \$11 million.⁹¹ The SF/SPCA campus had expanded to what the San Francisco Chronicle called a "vast Mission District complex," with 163 staff members and 2,345 volunteers.⁹² The SF/SPCA was, by any estimation, one of the most influential animal shelters in the country.

Avanzino's successor, Edwin Sayres, and Carl Friedman issued a joint compilation of statistics for the SF/SPCA and the SF/ACC for fiscal year 1998 to 1999.⁹³ This report showed an approximately 70% save rate for dogs and cats.⁹⁴ Although a 70% save rate is not noteworthy by today's standards, it was exceptional for a large city in the late 1990s. About 1,100 "treatable" dogs and cats, representing about 10% of combined intake, were killed during the fiscal year. The remaining 20% were classified as "non-rehabilitatable" and euthanized. Advances in veterinary medicine in general and shelter medicine in particular have made it possible to save many animals today who were not considered savable in the late 1990s. Today, many people consider the "non-rehabilitatable" portion of a typical shelter's intake to be in the low single digits.

Avanzino's tenure at the SF/SPCA was central to the development of No Kill. There were many No Kill shelters in existence when he became president of the SF/SPCA in 1976, but none of them had the responsibility to take in homeless animals for an entire city or county. As private shelters, they could avoid killing animals simply by refusing to take in more when they were full or refusing to take in animals who would be difficult to place. Avanzino's vision of the No Kill city, where the public and private sectors worked together to save all healthy and treatable shelter animals in the community, was a new concept. That

⁸⁷ Rubenstein, "Living Large"; Ippoliti-Smith, San Francisco Society for the Prevention of Cruelty to Animals, 2.

⁸⁸ Taimie Bryant, "Hayden Law Update" (2004), *Maddie's Fund: Animal Legislation*, accessed March 20, 2017, <http://www.maddiesfund.org/hayden-law-update.htm>.

⁸⁹ Laura Allen, "Legislature Rejects CA Gov. Brown Plan to Repeal Hayden Law," April 15, 2012, *Animal Law Coalition*, accessed March 20, 2017, <https://animallawcoalition.com/legislature-rejects-ca-gov-brown-plan-to-repeal-hayden-law/>; Taimie Bryant, "Hayden Law Update".

⁹⁰ Avanzino, interviews.

⁹¹ Martin, "Penthouse for Pets."

⁹² Ibid.

⁹³ *Partnerships for Life: Adoption Pact Fiscal Year Report July 1, 1998–June 30, 1999* (San Francisco: San Francisco SPCA and San Francisco Department of Animal Care and Control, 1999).

⁹⁴ The save rate would have been slightly higher if the 919 dogs and cats taken in by the SF/SPCA from outside the city had been counted in the statistical report. Subsequent reports showed that the combined percentage of dogs and cats saved remained roughly the same over the next three years, while combined intake gradually fell from almost 11,000 to about 7800.

concept, implemented through the programs developed by Avanzino and his staff, became the foundation of the No Kill movement.

Public-private partnerships in sheltering, where a private organization runs a public shelter by contract, have been around since 1870. The difference in San Francisco was that the city was a full partner with the private sector instead of simply handing over the reins. This model has great synergy. The city shelter typically handles animal control and at least some animal care and placement functions, while the private partner takes in at-risk animals, including animals who need rehabilitation or medical treatment to make them adoptable, and finds them new homes. The private partner, with its ability to effectively recruit donations and volunteers, is able to increase the overall resources available for the No Kill mission.

San Francisco was not quite alone in reaching a 70% community-wide live release rate by the end of the 1990s. In the next chapter, similar achievements in New Hampshire and the Denver metro area, as well as in several small towns, are described. But the shelter system that Avanzino and his staff built in San Francisco, with its twin pillars of lifesaving programs (described in chapter 15) and the shared public-private operational model described in this chapter, has proven to be a highly replicable system.

Chapter 17: Parallel No Kill Efforts

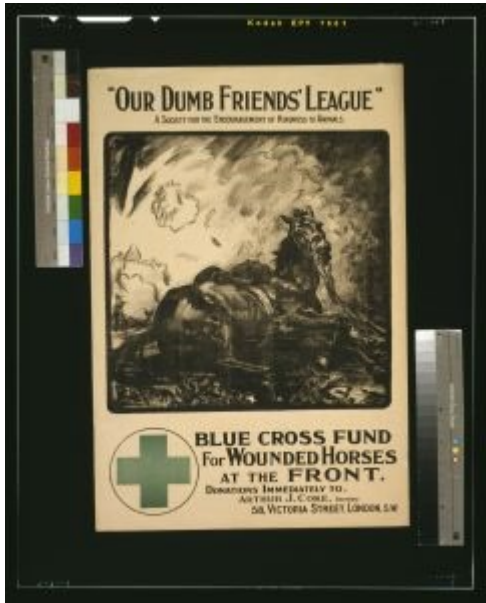

Figure 54:

The Denver Dumb Friends League was modeled after an English organization named Our Dumb Friends League. In the early 1900s, a primary meaning of the word “dumb” was “one who cannot speak.” Public domain.

San Francisco is often thought of as the first No Kill city, based on the 1994 Adoption Pact that was discussed in the last chapter. It was not quite alone in shelter lifesaving progress, however. By the end of the 1990s, the Denver metro area and the state of New Hampshire were saving around 70% to 80% of shelter intake, comparable to San Francisco. Those save rates were much better than the United States average. Estimates of the nationwide save rate in the late 1990s were generally around 35%, but it is possible that available statistics did not include a representative number of shelters from poorer performing areas.

The Denver Dumb Friends League (DFL), a private organization that was incorporated on September 20, 1910,¹ grew to play a dominant role in the Denver metro area. DFL operated out of a series of small buildings in its early years, then built a large shelter in 1948 that was a model for the time.² In 1974, DFL built a shelter on a 10-acre campus on Quebec Street which had adoption areas, glass-fronted adoption kennels, and an exercise yard.³ In the years since then DFL has continued to expand, including renovations on the Quebec Street campus.⁴ DFL opened a second full

service shelter called the Buddy Center in nearby Douglas County, Colorado, in April 2002.⁵

DFL’s long-time leader, Robert (“Bob”) Rohde, started work at the shelter as an animal care technician in 1973 and became executive director in 1977.⁶ DFL’s intake in 1973 was 44,000 animals, cared for by a staff of 17 people.⁷ The save rate was only 11%,⁸ which was typical for shelters at that time. By the year 2000, the number of animals taken in yearly by DFL had fallen to 24,000.⁹ This corresponded to the plunge in shelter intake seen across the United States from 1970 to 2000.¹⁰

Total intake in the Denver metro area in 1973 was considerably higher than the approximately 44,000 taken in by DFL that year. There were several other intake shelters in the area, including a public shelter run by

¹ Colorado Secretary of State, “The Denver Dumb Friends League.”

² *Dumb Friends League Board Manual* (Denver: Dumb Friends League, 2005), 1.

³ *Ibid.*; Robert Rohde, interviews by author, March 26, 2014 and April 13, 2016.

⁴ Robert Rohde, “History of the Dumb Friends League,” undated presentation.

⁵ *Dumb Friends League Board Manual*, 2.

⁶ “Robert D. Rohde, President and CEO,” *Dumb Friends League*, accessed March 21, 2017, <http://www.ddfl.org/about-us/our-leadership-team/robert-d-rohde-president-and-ceo/>.

⁷ Rohde, interviews; Rohde, “History of the Dumb Friends League.”

⁸ Rohde, interviews.

⁹ *Ibid.*; Colorado Revised Statutes, Title 35, Article 80: **Pet Animal Care And Facilities Act**, Sections 35–80–101 to 35–80–117, statistical report for the year 2000.

¹⁰ See chapter 10.

the city of Denver that dated back to the late 1800s and did animal control.¹¹ The Denver city shelter in 1973 had four “gang pens” for dogs.¹² All the dogs caught on a given day were put together in one pen, and each day the pen with the dogs who had been there the longest was emptied by killing the unclaimed dogs.

Rohde did not collaborate with Richard Avanzino, the head of the San Francisco SPCA from 1976 to 1998, but they independently developed many of the same programs. Rohde and Avanzino both report that, although they sometimes heard about what other people were doing, they made reforms based on what made sense for their individual shelters.¹³ In 1981, DFL implemented a volunteer program.¹⁴ In 1983, DFL began to treat cats with upper respiratory infections.¹⁵ DFL formalized its foster program in 1987.¹⁶ In 1989, DFL began early age spay-neuter on site.¹⁷ In 1991, the DFL Animal Behavior Program was founded,¹⁸ and in 1995, DFL started a telephone help service to counsel people on pet behavior issues.¹⁹ DFL also did mobile adoptions.²⁰

A Denver veterinarian named Rob Hilsenroth conducted a survey in the metro area in 1987 and estimated that roughly 75,000 animals were dying in metro area shelters each year. Hilsenroth had a television show and, as he said to his viewers, enough animals were dying in metro Denver shelters each year to fill every seat in the Mile High Stadium.²¹ Rohde and other shelter leaders in the area were very successful at reducing that number in the 1990s, and they believe their history of collaboration was key.²²



Figure 55:
In the 1980s, enough animals were dying in Denver metro area shelters each year to fill every seat in the Mile High Stadium. Public domain.

The first formal collaborative effort in the area was the Metro Animal Services Council, created in the 1970s by Rohde and others.²³ The purpose was to provide a centralized tracking system for lost pets. There were other collaborations over the years.

¹¹ David Gies et al., “Working Together Works: Building Strategic Collaborations to Reduce Pet Euthanasia,” paper presented at *Animal Care Expo*, April 4, 2003, 1.

¹² Rohde, interviews.

¹³ Ibid.; Richard Avanzino, interview by author, August 15, 2014.

¹⁴ Rohde, email message to author, April 14, 2016.

¹⁵ Rohde, “History of the Dumb Friends League.”

¹⁶ *Dumb Friends League Board Manual*, 1; Rohde, interviews.

¹⁷ *Dumb Friends League Board Manual*, 1.

¹⁸ Ibid.

¹⁹ Bill Theobald and Bonnie Harris, “Killing is Down in Other Cities,” *Indy Star*, October 16, 2001.

²⁰ Rohde, “History of the Dumb Friends League.”

²¹ Rohde, interviews.

²² Gies et al., “Working Together Works,” 2

²³ Ibid.

Since the year 2000, the major collaborative effort has been the Metro Denver Shelter Alliance.²⁴ The Alliance grew out of collaborations that had resulted from the passage of the Pet Animal Care Facilities Act (PACFA) by the Colorado state legislature in 1993. The necessity of developing regulations to implement the Act brought animal control agencies and rescue groups together in the 1990s to help draft the new rules. The Colorado Federation of Animal Welfare Agencies also served as a way for people in the metro area to get to know each other and work together.

The four largest shelters in the Denver metro area in the 1990s were DFL, the Denver city shelter (Denver Municipal Animal Shelter), Aurora Animal Shelter, and Table Mountain Animal Center (now Foothills Animal Shelter).²⁵ Those shelters served Arapahoe County, Denver County, and Jefferson County, and together they took in about 80% of the cats and dogs who came into shelters in those counties.²⁶ In the year 2000, those four shelters reported a combined save rate of 70% for dogs and cats (74% for dogs and 65% for cats).²⁷ The save rate was also 70% when two other large metro area shelters, the Humane Society of Boulder Valley (HSBV) and the Adams County shelter, were included.²⁸ This is very close to the combined save rate reported by the San Francisco SPCA and the San Francisco city shelter for fiscal year 1998 to 1999.²⁹

In addition to collaboration among the shelters and rescues in the Denver metro region, Rohde credits the nature of the Denver community for their success.³⁰ He believes that a shelter's success is dependent in large part on the resources it has available, both human and financial, and that although cooperation among agencies and good management can go a long way in raising the number of live releases, it is unfair to blame shelter management in cases where the real problem is a lack of resources.³¹ As he put it, if DFL were to be transferred to an economically distressed city, they could probably improve on the current performance of the city shelter, but they would not be able to bring it up to the level they have achieved in Denver because they would not have the community resources that they have in Denver.

HSBV was one of the most successful public shelters in the Denver metro region in the 1990s. In the early 1990s, HSBV was saving about 60% of its intake, but that number began to climb when director Kelly Rogers set a goal in 1993 to save all adoptable animals by 1996.³² Some of the programs Rogers added were mobile adoptions, subsidized spay-neuter, behavior consultations to reduce the number of animals surrendered, and efforts to increase return-to-owner rates. HSBV was at a 75% save rate by 1996, and the shelter continued to improve thereafter. Jan McHugh-Smith, who became director of HSBV in 1995, added expanded veterinary services and revamped how the shelter did adoptions. The Open Adoption program she pioneered at HSBV in 1997 had national influence.³³

McHugh-Smith was “definitely influenced” by the work that Richard Avanzino had done at the San Francisco SPCA.³⁴ She felt that his work in making San Francisco the “safest community in America”

²⁴ Ibid.

²⁵ Kevin Morris and David Gies, “Trends in Intake and Outcome Data for Animal Shelters in a Large U.S. Metropolitan Area, 1989 to 2010,” *Journal of Applied Animal Welfare Science* 17, no. 1 (2014): 60, doi:10.1080/10888705.2014.856250.

²⁶ Ibid.; Colorado Revised Statutes, Title 35, Article 80, statistical report for the year 2000.

²⁷ Colorado Revised Statutes, Title 35, Article 80, statistical report for the year 2000.

²⁸ Ibid.

²⁹ “Partnerships for Life: Adoption Pact Fiscal Year Report July 1, 1998–June 30, 1999, *San Francisco SPCA and San Francisco Department of Animal Care and Control*, 1999.

³⁰ Rohde, interviews.

³¹ Ibid.

³² Jan McHugh-Smith, e-mail message to author, July 26, 2016.

³³ See chapter 20.

³⁴ McHugh-Smith, interview.

helped change public perceptions so that people thought of adopting a shelter animal as “the right thing to do.” And she credits much of the success in raising save rates in Colorado to Rohde. She said that in his over 40 years of work in the Denver area he had been able to “pull people together and help people work together.”³⁵

As the Denver metro area was making progress by collaboration, New Hampshire was making progress with an innovative spay-neuter program. The northeast part of the United States generally, and New England in particular, has had a reputation since at least the 1990s for better shelter-lifesaving performance than most other areas of the country, and that has been attributed in part to higher rates of pet sterilization. New Hampshire made pet sterilization a state priority.

In 1994, a state-sponsored low-cost spay-neuter program went into effect in New Hampshire.³⁶ The program was a variation on low-cost sterilization in that, instead of simply offering a discount, New Hampshire made pet sterilization available to qualifying pet owners for only \$10.00 (later increased to \$25.00).³⁷ Participants had to be eligible for a low-income assistance program to qualify.³⁸ A companion provision allowed people who adopted unsterilized animals from shelters to have them sterilized for a copayment of \$25.00 (later increased to \$40.00), regardless of the owner’s income.³⁹

The New Hampshire Federation of Humane Organizations (NHFHO), which includes most of the state’s animal shelters, has collected statistics from its member organizations since 1983. The NHFHO estimates that its statistics include more than 95% of animals taken into shelters in New Hampshire.⁴⁰ From 1993, the year before the state spay-neuter program started, to 2000, the number of cats entering NHFHO shelters dropped from 14,302 to 9,085, and the number killed dropped from 9,829 to 1,941.⁴¹ The number of dogs taken in dropped from 5,079 to 3,715, and the number killed dropped from 1,665 to 634. A statistical analysis of the New Hampshire spay-neuter program concluded that the program correlated with a decline in intake and euthanasia for cats, but that a pre-existing downward trend in dog intake and euthanasia did not accelerate.⁴²

In addition to the state-sponsored spay-neuter initiative, shelters in New Hampshire, in the 1990s, were trying a variety of other methods to reduce shelter killing. As Bert Troughton, director of one of the New Hampshire shelters in the 1990s, said:

“We were throwing everything, including the kitchen sink at the problem. We were examining overly strict adoption criteria, updating our adoption contracts, improving customer service, working more closely with [Animal Control Officers] to do better/more [Return to Owner], start[ing] foster care (at our shelter, this actually started with adolescent dogs going home with staff to work out some of their exuberance—and then it really took off when we started recruiting folks to take litters of kittens home), and working more closely on a state-wide basis between our organizations to share everything we were trying to see what was working.”⁴³

³⁵ Ibid.

³⁶ See chapter 10 for a discussion of how this program developed in the context of the spay-neuter movement of the 1990s.

³⁷ Sara White, Ellen Jefferson, and Julie Levy, “Impact of Publicly Sponsored Neutering Programs on Animal Population Dynamics at Animal Shelters: The New Hampshire and Austin Experiences,” *Journal of Applied Animal Welfare Science* 13, no. 3 (2010): 193, doi10.1080/10888700903579903.

³⁸ Peter Marsh, email messages to author, March 2, 2014, and July 26, 2016.

³⁹ White, Jefferson, and Levy, “Impact of Publicly Sponsored Neutering Programs,” 193.

⁴⁰ Ibid., 194.

⁴¹ Marsh, email messages.

⁴² White, Jefferson, and Levy, “Impact of Publicly Sponsored Neutering Programs,” 204.

⁴³ Bert Troughton, email message to author, March 18, 2014.

By the year 2000, the New Hampshire shelters that were part of the NHFHO were reporting an aggregate save rate of 80% for cats and dogs. We cannot say with certainty that the 80% save rate applied to the state as a whole, because not all intake organizations were members of the NHFHO and we do not know whether any transfers within the state were double-counted as live releases. It appears, though, that New Hampshire save rates circa 2000 were comparable to if not better than San Francisco and Denver.

In addition to San Francisco, the Denver metro area, and the state of New Hampshire, which were reporting 70% to 80% of shelter animals saved by the year 2000, there were also small public shelters in several towns and counties that were reporting save rates of over 90% by 2000. As discussed in chapter 20, possibly the first such community was Kane County, Utah, which started saving all healthy and treatable animals in the mid-1980s when the Best Friends Animal Society took over the shelter.

Otsego County, Michigan, reportedly began to save all of its healthy and treatable animals in the late 1990s with the help of a group of citizens called Friends for Life.⁴⁴ The county adopted a resolution in 1999 stating: “ONLY those animals which are received in a condition of terminal illness or mortal injury that are beyond clinical redemption for any reasonable quality of life will still continue to be destroyed, as would such animals that are aggressive and/or dangerous and cannot be successfully rehabilitated with available resources.”⁴⁵ The Otsego shelter reportedly had a “reclaiming/adoption” rate of 99.5% in 1999 and 98.75% in 2000.⁴⁶

Colorado’s PACFA law requires that shelters report statistics to the state.⁴⁷ Several small municipal shelters in Colorado reported save rates of 90% or above for the year 2000, the first year of reporting. Those shelters included the Aspen Animal Shelter, Surface Creek Shelter, Eagle County Animal Services, Clear Creek/Gilpin County, Telluride Animal Shelter, Leadville/Lake County, Teller County Regional Animal Shelter, and Rifle Animal Shelter.⁴⁸



Figure 56:
This photograph of a frozen river in New Hampshire illustrates some of the challenges facing outdoor dogs and cats in the northern U.S. Photograph by Kieran Hunt, licensed under CC BY-SA 4.0.

Why were some small communities able to begin saving 90% or more of their shelter intake in the late 1990s, while even the best large cities and regions were able to get only to the 70% to 80% range? It might be because a small number of people can have a greater impact in a small community, as happened in Otsego County. Another factor may be that some small communities have high education levels and household income, with the result that fewer animals per person may enter the shelter, the animals who do enter the shelter may be healthier and more adoptable, and the community may provide the shelter with more resources. Other factors such as climate, terrain, the

⁴⁴ Melissa FitzGerald, “Case Study: Michigan’s 1st No Kill Community,” presentation at Michigan Pet Fund Alliance Conference (2013).

⁴⁵ Otsego County Resolution No. 1999–31, May 11, 1999, accessed April 30, 2017, <http://www.otsegocountymi.gov/wp-content/uploads/2015/12/OCR-1999-31-No-Kill-Policy.pdf>.

⁴⁶ “Summary,” *Friends for Life*, Internet Archive, <https://web.archive.org/web/20141229083712/http://www.otsego.org/ffinc/nokill.htm>.

⁴⁷ Colorado Revised Statutes, Title 35, Article 80.

⁴⁸ Colorado Revised Statutes, Title 35, Article 80, statistical report for the year 2000.

presence of a humane society in the community, and the availability of veterinary services may also have disproportionate impact in a small town.

By the year 2000, there were many examples of cities and towns in the United States that had greatly reduced shelter killing. Those communities had taken advantage of the precipitous decline in shelter intake from 1970 to 2000 and the development of more effective programs and models for shelter operations to go from killing most of their intake to saving a high percentage. The next Part looks at the emergence of a movement in the 1990s to bring No Kill to all shelters nationwide.

Part VI: The No Kill Movement

Chapter 18: The Human Toll of the Traditional Shelter

Chapters 19 and 20 discuss the grassroots No Kill movement that had its origins in the 1970s and 1980s and became an important force in animal sheltering in the 1990s. To understand the development of the No Kill movement, it is necessary to look at the psychological factors that influenced workers in traditional shelters. These psychological factors played a large role in the reaction of the traditional shelter establishment to No Kill.

Workers in traditional public shelters in the 1900s either directly killed or witnessed the killing of the great majority of animals who came in the door, most of whom were healthy and adoptable. An American Humane Association (AHA) official estimated in 1974 at the height of the pet population crisis¹ that, on average, shelters in the United States were killing 90% of their intake.² Things improved slightly in the 1980s, but kill rates were still high into the 1990s. The ASPCA, for example, killed over 75% of the cats and dogs it impounded in 1994 under its contract with New York City.³

Shelter workers saw high levels of killing as a necessity in those years because there were not enough homes for the number of animals coming into shelters, not to mention the number of homeless animals in the environment who never came into shelters. This view of the necessity of shelter killing was illustrated in a 1978 essay written by Phyllis Wright, the head of shelter issues for the Humane Society of the United States. The essay, titled “Why Must We Euthanize?” was widely read, and shelter workers could point to it when members of the public accused them of being uncaring.⁴

Wright argued that dogs and cats, as domesticated animals who had been selectively bred to be pets, needed a home and family to have a good quality of life. She identified companionship with humans as one of the most important factors in the lives of cats and dogs, and argued that the lack of human companionship in a home setting caused actual suffering to homeless pets. She believed that a dog or cat who did not have its own home and loving family would inevitably suffer to the point that humane killing was a preferable alternative to life in a kennel. Wright’s emphasis on preventing suffering echoed the outlook of the early SPCAs and humane societies in the late 1800s that worked to stop cruelty to animals.

Dr. Murry Cohen, a psychiatrist who fought for better treatment of animals used in laboratory experiments, noted at a 1987 conference that humans created dogs and cats and caused their excess numbers by providing conditions that protected them from the vicissitudes of nature.⁵ He argued that death could be an acceptable outcome for homeless dogs and cats when there were no satisfactory alternatives.⁶

Another major issue in the ethics of shelter killing in the latter half of the 20th century was pound seizure.⁷ Shelter animals who were seized by researchers could be used in experiments that were often prolonged

¹ See chapters 8 and 10.

² Rutherford Phillips, “Problems of Euthanasia and Adoption,” in *Proceedings of the National Conference on the Ecology of the Surplus Dog and Cat Problem, May 21–23, 1974* (Denver: American Humane Association, 1974), 52.

³ Stephen Zawistowski et al., “Population Dynamics, Overpopulation, and the Welfare of Companion Animals: New Insights on Old and New Data,” *Journal of Applied Animal Welfare Science* 1, no. 3 (1998): 202, table 4, doi:10.1207/s15327604jaws0103_1.

⁴ Phyllis Wright, “Why Must We Euthanize?” (1978), reprinted in *Shelter Sense*, October 1995, 7–8.

⁵ Murry Cohen, “Attitudes Toward Neutering and Euthanasia,” in *Overpopulation of Cats and Dogs: Causes, Effects, and Prevention*, ed. Marjorie Anchel (New York: Fordham University Press, 1990), 198–199.

⁶ *Ibid.*, 199.

⁷ See chapter 7.

and excruciatingly painful, with little or no anesthesia. An animal who was killed painlessly in a shelter was at least safe from torture in a laboratory.

Various terms have been used to describe the act of killing an animal in a shelter. The term “put to sleep” was in use by the late 1800s and early 1900s for killing animals in gas chambers.⁸ In its Annual Report for 1909, the Women’s Branch of the Pennsylvania SPCA (by then known as the Women’s Pennsylvania SPCA) used the phrase “humanely put to death” to describe the outcome for most of the dogs at its shelter.⁹ By the 1960s, “euthanasia” had become a common term for shelter killing, as well as for killing animals who had been used in research and product testing.¹⁰ In 1963, the first American Veterinary Medical Association (AVMA) “Panel on Euthanasia” was convened.¹¹ The term “euthanasia” for shelter killing appears to have been fairly well accepted by the general population and the news media, although one newspaper columnist expressed the view in 1963 that euthanasia for animals benefitted the people doing the euthanizing, not the animals being euthanized.¹²

The word “euthanasia” has been in use for hundreds of years in the context of a merciful death for a person who can no longer live a tolerable life due to illness or injury, but most animals who were killed in shelters in the 20th century were healthy. Tom Regan, a prominent animal rights philosopher, addressed the use of the term “euthanasia” to describe shelter killing in his 1983 book *The Case for Animal Rights*.¹³ He pointed out that the two Greek roots of the word mean “good death.” He defined the proper use of “euthanasia” of an animal to refer to a killing that is as painless as possible, is done in the objectively correct belief that death is in the interest of the animal being killed, and is in accord with the animal’s preferences.¹⁴ Thus, killing an animal who is in severe pain that cannot be relieved by treatment is euthanasia. Killing healthy animals in shelters should not be called “euthanasia,” in Regan’s view, because such killings are not in accord with the animals’ preferences and are not objectively in their interest.¹⁵ Healthy animals who are killed in shelters to make room for other animals are “killed,” not “euthanized.”¹⁶

Regan drew a distinction that is often overlooked in discussions about the term “euthanasia,” which is that although shelter killing of healthy animals is not “euthanasia” by definition, that does not entail that shelter killing cannot be a morally preferable alternative.¹⁷ He expounded on the morality of shelter killing in a short talk he gave at a 1987 conference, calling it a “terribly difficult problem.”¹⁸ He approached the problem by pointing out that the rights inherent in being human make it morally wrong for one human to treat another

⁸ See, e.g., “Dogs and Cats in Pound,” *New York Times*, September 14, 1895. The term “put to sleep” had been used for decades before this to refer to bringing on states of temporary insensibility in humans by anesthesia or hypnosis. Some people in the early 1900s used the term “put to sleep permanently” to clarify that an animal was being killed and not just anesthetized.

⁹ Women’s Pennsylvania Society for the Prevention of Cruelty to Animals, *Forty-First Annual Report* (1910), 24.

¹⁰ See, e.g., Truman Twill, “Purely Personal,” *Steubenville Herald-Star*, May 21, 1963.

¹¹ American Veterinary Medical Association, *AVMA Guidelines for the Euthanasia of Animals: 2013 Edition* (Schaumburg, IL: American Veterinary Medical Association, 2013), 5, <https://www.avma.org/kb/policies/documents/euthanasia.pdf>.

¹² Twill, “Purely Personal.”

¹³ Tom Regan, *The Case for Animal Rights* (1983; repr., Berkeley: University of California Press, 1985), 109.

¹⁴ *Ibid.*, 109–114.

¹⁵ *Ibid.*, 114–116.

¹⁶ *Ibid.*, 119.

¹⁷ *Ibid.*, 115–116.

¹⁸ Tom Regan, “Attitudes Toward Neutering and Euthanasia,” in *Overpopulation of Cats and Dogs*, 210–214.

human solely as a means to an end.¹⁹ He called this the principle of “respect,” and said that in the treatment of healthy shelter animals, any killing that is moral must show this type of respect for the animal.

Regan said that rationalizing shelter killing as necessary for the good of society failed to show respect to the individual animal because it addressed the good of others, not the good of that particular animal.²⁰ He concluded that the best solution he could offer was to show each animal respect by treating each one equally. He suggested that this might be accomplished by shelters making it a policy to give each animal a period of time to be available for adoption. In order to show all animals equal respect, both inside and outside the shelter, the amount of time given each animal would have to depend on the number of animals waiting to enter the shelter.²¹ The struggle of this philosopher who was devoted to the cause of animal rights with the issue of the morality of shelter killing illustrates how hard the problem was under the circumstances of pet overpopulation that existed in the 1970s and 1980s.



Figure 57:
Philosopher Tom Regan. Public domain.

Phyllis Wright’s argument that killing shelter animals was necessary to prevent their suffering might be seen as defining “euthanasia” more broadly than Regan did. Under this broader definition, killing a shelter animal is “euthanasia” when not enough homes are available, because a home is essential for a pet animal to have a good quality of life. If Wright had addressed Regan’s definition of “euthanasia” she might have said that when a home for a cat or dog could not be found, death was in the best interest of the animal and in accord with its preferences because dogs and cats actively suffered when they did not have a home.

The traditional shelter industry has tended to avoid the very difficult ethical issues associated with the term “euthanasia” by simply defining euthanasia for animals as a painless death. Rutherford Phillips, the executive director of the AHA, expressed this view at a 1974 conference when he stated: “Euthanasia means a humane death.”²² The AVMA, in the 2013 iteration of its guidelines for euthanasia, noted that euthanasia of an animal typically refers to “ending the life” of an animal by a method that “minimizes or eliminates pain and distress.”²³ The guidelines say: “A good death is tantamount to the humane termination of an animal’s life.”²⁴ The AVMA observed that although there is debate about the use of the term “euthanasia” for killing shelter animals, not all shelter animals are fit for adoption and not all are wanted.²⁵ The AVMA concluded that there is no clear formula for deciding whether euthanasia of a particular animal is appropriate, and its guidelines were designed to help veterinarians who are struggling with the issue.²⁶

¹⁹ *Ibid.*, 212.

²⁰ *Ibid.*, 213.

²¹ *Ibid.*, 213–214.

²² Phillips, “Problems of Euthanasia and Adoption,” 53.

²³ American Veterinary Medical Association, *AVMA Guidelines*, 6.

²⁴ *Ibid.* The formal definition of “euthanasia” in the guidelines refers to minimizing pain and fear and causing rapid unconsciousness followed by death. *Ibid.*, 98.

²⁵ *Ibid.*, 6

²⁶ *Ibid.*, 9.



Figure 58:

In recent years, the stress caused by caregiving has received more attention, as in this 2015 panel discussion. Public domain.

The idea that killing shelter animals was justified due to the lack of homes for them, which was the theme of Wright's 1978 essay, became enshrined in the maxim that for shelter animals "killing was a kindness" in and of itself. The justification that killing was a necessity and the rationalization that killing was a kindness did not make killing easy for shelter workers, however, even when they believed that death was the best of the available options for an animal. Shelter workers reported concentration and sleep problems, depression, family conflict, and drug and alcohol abuse, as well as burnout and job dissatisfaction.²⁷ A 1993 book aimed at shelter workers listed more than a dozen consultants who dealt with euthanasia stress.²⁸ A 2013 study found that over half of shelter workers reported sadness, crying,

anger, depression, irritability, grief, and rationalization.²⁹

Shelter workers are somewhat unusual in the caring professions in that they can experience three levels of stress. First, there is the typical stress (often called "compassion fatigue") that can be found in any caring profession. A manager at Bideawee, a shelter that does not kill animals who are healthy or treatable, said at a 1987 conference that even workers in "non-euthanasia" shelters can burn out from their inability to help all the animals who need help.³⁰ This first level of stress can be especially severe for animal-control officers and others who frequently deal with cruelty cases.

Another level of stress is felt by workers who kill shelter animals. A study published in 2005 found that workers who were "directly involved in euthanasia" had significantly higher levels of stress-related symptoms and issues than those who were not.³¹ Finally, shelter workers experience a third layer of stress that comes from public censure of shelter killing. Unlike workers in most of the caring professions, who are praised for their work, shelter workers receive criticism and even condemnation from the public for the killing of adoptable animals. The isolation from the public that shelter workers experience over this issue sometimes extends even to friends and family.³²

Bernard Rollin, a professor of philosophy, concluded that jobs that require the killing of animals for reasons that do not directly benefit the animals themselves result in what he called "moral stress."³³ In Rollin's work with people whose primary job was killing shelter animals, he found that typical techniques recommended for stress relief were useless. At one "euthanasia" conference he attended, a psychologist's suggestion that

²⁷ Humane Society of the United States, *Euthanasia Reference Manual*, 2nd ed. (n.p.: Humane Society of the United States, 2013), 69.

²⁸ B. J. Ellis, *Paws for Thought: A Look at the Conflicts, Questions and Challenges of Animal Euthanasia* (Columbia, SC: Paw Print Press, 1993), 122–124.

²⁹ Keith Anderson et al., "Euthanasia in Animal Shelters: Management's Perspective on Staff Reactions and Support Programs," *Anthrozoös* 26, no. 4 (2013): 573, doi:10.2752/175303713X13795775536057.

³⁰ Kathleen Young, "Responsibilities of Shelters," panel discussion in *Overpopulation of Cats and Dogs*, 113.

³¹ Charlie Reeve et al., "The Caring-Killing Paradox: Euthanasia-Related Strain Among Animal-Shelter Workers," *Journal of Applied Social Psychology* 35, no. 1(2005): 135, doi:10.1111/j.1559-1816.2005.tb02096.x.

³² Rhonda Donald and Chris Powell, "A Piece of Us Dies Every Time," *Shelter Sense* 12, no. 10, (November 1989): 2.

³³ Bernard Rollin, "Animal Euthanasia and Moral Stress," in *Euthanasia of the Companion Animal: The Impact on Pet Owners, Veterinarians, and Society*, ed. William Kay et al (Philadelphia: Charles Press, 1988), 33.

shelter workers try visualizing pleasant scenes as a relaxation technique was met with hostility by the workers, who felt that the suggestion demonstrated a failure to understand what they were experiencing.³⁴ The only effective way to deal with this moral stress, in Rollin's view, was for workers to develop their own ethic for how shelters should function and then do everything they could to make that ethic a reality.³⁵

Arnold Arluke, professor emeritus at Northeastern University in Boston, used the term "caring-killing paradox" to describe what he found in a study of animal care workers at a shelter in a large city.³⁶ The "paradox" was the conflict between a job that people took because they wanted to help animals and the reality that they often had to kill those animals. Arluke described newly hired shelter workers as being unprepared for killing healthy shelter animals, noting that many times they became attached to particular animals and related to them as they would to their own pets.³⁷ There was a self-selection process for shelter workers, and the few who could not accept the justifications for killing quit their jobs.³⁸ Workers who did not quit sometimes had doubts or periods of regret or remorse when they questioned their participation in shelter killing.³⁹

New workers gradually became institutionalized to the culture of the shelter and developed strategies to reduce the tension between their idealistic wishes to care for animals and the reality of having to kill them. The strategies often included distancing themselves in some way. The workers might come to see their relationship to a shelter animal merely as caretaker while the animal was in the shelter, or they might focus on making sure the animal felt safe and comfortable as it was being killed.⁴⁰ Another coping mechanism was ritualizing the process of killing, making it a good thing, perhaps the only kindness the animal ever received. One shelter employee in Arluke's study said: "They get more love in the last few seconds than they ever did."⁴¹

In the shelter that Arluke studied, the workers had to select which animals to kill. In the case of old or sick animals, it was relatively easy to assign a reason for the animal's selection, and to believe that the killing was justified to prevent suffering.⁴² With healthy, friendly animals, a justification for killing was not so obvious. In those cases, workers tended to focus on the bleak future prospects of the animals, including the very real possibility that the animals would go crazy from stress if kept in the shelter too long, or the cruelty or neglect they might experience if they were adopted out to inappropriate homes.⁴³

There were two views about adoption in the animal shelter world. One was that shelters should not hold out for a perfect home, and the other, which was sometimes attributed to shelter workers seeing many cruelty cases, was that animals were better off dead than in a home that was less than perfect.⁴⁴ Many workers saw shelters as a safe haven from a cruel world.⁴⁵ Dennis Fetko, an animal behaviorist, expressed a view commonly held by shelter workers when he said in the early 1990s that death was not the worst

³⁴ Ibid., 35–36.

³⁵ Ibid., 36.

³⁶ Arnold Arluke, "Managing Emotions in an Animal Shelter," in *Animals and Human Society: Changing Perspectives*, ed. Aubrey Manning and James Serpell (1994; repr. New York: Routledge, 2011), 147.

³⁷ Ibid., 146–147.

³⁸ Ibid., 159–160.

³⁹ Ibid., 160–161.

⁴⁰ Ibid., 148–153.

⁴¹ Ibid., 151.

⁴² Ibid., 152.

⁴³ Ibid., 152–154.

⁴⁴ Patricia Curtis, *The Animal Shelter* (New York: E. P. Dutton/Lodestar Books, 1984), 137–139; American Humane Association, *1999 Adoption Forum* (Englewood, CO: American Humane Association, 1999), 2.

⁴⁵ Craig Brestrup, *Disposable Animals: Ending the Tragedy of Throwaway Pets* (Leander, TX: Camino Bay Books 1997), 26.

thing that could happen to an animal.⁴⁶ Craig Brestrup, a No Kill shelter director and author, called this the “fates worse than death” outlook, and described it as “catastrophization.” He noted that this outlook “assumes that each compassionately killed animal has been spared not simply a less than ideally desirable life but an unspeakable fate.”⁴⁷ As he put it: “Of ‘deaths worse than fate’ we hear nothing.”⁴⁸

Another coping mechanism for shelter workers was to assign responsibility for shelter killing to pet owners who allowed their pets to breed, or who gave their pets up to the shelter.⁴⁹ Shelter workers saw themselves, along with the animals, as victims of owner irresponsibility. They often said that they were doing the dirty work, or cleaning up the mess that others had made, or shouldering a burden that others had dropped.⁵⁰ This made it all the more galling when people failed to recognize the sacrifice they were making and instead said things like “I love animals too much to do your work.”⁵¹ As shelter workers saw the situation, criticism from the public was unjust because it was the public’s irresponsibility that made shelter killing necessary in the first place.⁵² Shelter workers would often discount criticism as coming from people who did not understand the situation.⁵³ When asked why they remained in a job that caused them so much distress, shelter workers might say that they stayed because there was no one else to care about the animals the way they did.⁵⁴

People who counseled shelter workers made use of fables and images to not only help the workers cope with what they faced, but to explain shelter killing to outsiders. Phyllis Wright often said in connection with her work to promote spaying and neutering that when you are up to your neck in alligators you have to drain the swamp.⁵⁵ Douglas Fakkema, who has for years provided workshops for shelter workers on compassion fatigue, made an analogy to a person standing on a riverbank who saw babies floating downstream with the current, far too many for the onlooker to save.⁵⁶ The initial impulse of a person in that situation would be to jump in and start saving as many babies as possible, but more babies will be saved by going upstream to find whoever is throwing the babies in the river and stop them. This parable supported the idea that spaying and neutering was the solution to the problem of shelter killing.

Fakkema identified four stages that shelter workers go through—a honeymoon where newly hired workers believe that they can change the world and make things better for animals, depression when they realize the magnitude of the task and the fact that there is no solution within their power, anger at a world that created such a problem, and finally the resilience that comes with regaining a balance in life and realizing that making a difference involves taking one small step at a time.⁵⁷ The key to dealing with the stress of the shelter worker’s job, in Fakkema’s view, was to have a larger goal. This echoed Rollin’s idea that the solution for the moral stress suffered by shelter workers was to work to change the circumstances that made killing necessary. Some of the shelter workers in Arluke’s study reacted to shelter killing by becoming

⁴⁶ Ellis, *Paws for Thought*, 49.

⁴⁷ Brestrup, *Disposable Animals*, 36.

⁴⁸ *Ibid.*

⁴⁹ Arluke, “Managing Emotions in an Animal Shelter,” 155–157.

⁵⁰ Charles Figley and Robert Roop, *Compassion Fatigue in the Animal-Care Community* (Washington, DC: Humane Society Press, 2006), 44; Reeve et al., “The Caring-Killing Paradox,” 139.

⁵¹ Figley and Roop, *Compassion Fatigue*, 45; Kathryn Smith, “Why We Do What We Do,” *NACA News*, May-June 2000, 34.

⁵² Donald and Powell, “A Piece of Us Dies Every Time,” 2.

⁵³ Arluke, “Managing Emotions in an Animal Shelter,” 159.

⁵⁴ Figley and Roop, *Compassion Fatigue*, 45; Smith, “Why We Do What We Do,” 34.

⁵⁵ Carter Luke, interview by author, April 28, 2014.

⁵⁶ This story has been used in other contexts, including public health. See, e.g., “The Story of the River Babies,” *FAS Arizona*, accessed March 22, 2017, <http://fasarizona.com/riverbabies.htm>; “River Story,” *Prevent Connect*, accessed March 22, 2017, <http://wiki.preventconnect.org/River+Story>.

⁵⁷ “Articles,” *Douglas Fakkema*, accessed March 22, 2017, <http://www.dougfakkema.com/articles.html>.

involved in efforts such as spay-neuter campaigns or working on promoting adoption or educating the public.⁵⁸

By the mid-1990s, the spay-neuter movement, and possibly other factors, had reduced shelter intake and the number of homeless animals in the environment to the point where in some parts of the country there was no longer a hopeless imbalance between the number of homeless pets and the number of people willing to adopt from a shelter.⁵⁹ In the San Francisco and Denver metro areas and the state of New Hampshire, shelter staff had taken advantage of this new era to work on substantially increasing the number of animals released from the shelter alive.⁶⁰

The sharp decline in the number of homeless pets in the years from 1970 to 2000, along with an increase in the number of potential homes for shelter animals as the human population grew, placed more and more strain on the system of justifications and rationalizations that surrounded shelter killing. The increasing status of companion animals, and the existence of shelters like Bideawee and North Shore Animal League that did not kill healthy or treatable animals, may have driven an increasing awareness of and distaste for shelter killing on the part of the public. Controversy over shelter killing came to a head in the late 1990s with the rapid growth of the No Kill movement into a national force. That movement directly challenged the idea that shelter killing was a kindness, and argued that another solution must be found.

The “killing is a kindness” mentality among traditional shelter workers was nevertheless resistant to change. As late as 2013, 46% of workers in traditional animal shelters in one study felt that they were benefiting shelter animals by performing “euthanasia.”⁶¹ Animal rights activist Edward Duvin, whose work is discussed in the next chapter and who knew hundreds of people in the shelter industry, said that in his experience “many traditional shelter workers continue to justify a ‘killing them kindly’ ethos because it enables them to sustain their rationale for killing animals under their care, as denial serves as a protective barrier to profound regret and guilt.”⁶²

The difficulties that shelter workers continued to face were not just psychological, however. Although average shelter intake nationwide had plummeted by the year 2000, conditions varied widely from one place to another, as did the level of resources available to shelters. These factors were often beyond the control of individual shelter workers. The mental and physical health of shelter workers is not often mentioned as a reason for animal shelter reform, but it would appear that efforts to increase positive outcomes for shelter animals can help both shelter animals and shelter workers.

⁵⁸ Arluke, “Managing Emotions in an Animal Shelter,” 157.

⁵⁹ See chapter 10.

⁶⁰ See chapters 15–17.

⁶¹ Anderson et al., “Euthanasia in Animal Shelters,” 573.

⁶² Edward Duvin, email message to author, June 9, 2016.

Chapter 19: In the Name of Mercy

The No Kill movement in the United States is often said to have started in 1989, due to two events that happened that year.¹ One was that the San Francisco SPCA terminated its contract to run animal control and sheltering for the city, with consequences that were discussed in chapter 16. The other was that Edward Duvin published an essay called *In the Name of Mercy*.

Duvin was a social-change activist and non-profit consultant who advocated for animal rights. Assertions of “animal rights” were made as far back as the 1700s and 1800s, but in most cases were merely calls for animals to be treated without cruelty and not killed for trivial reasons. For example, Herman Daggett’s 1791 speech *The Rights of Animals* presupposed that the right of humans to use animals for food and other purposes trumped any right that an animal had to its own life.² Although Daggett used the term “rights,” his position was not significantly different from the views of other 18th century anti-cruelty advocates.



Figure 59:
Ed Duvin, circa 1998. Courtesy of Maddie’s Fund®.

The few people in the 19th century who made more rigorous assertions of animal rights had little impact. Lewis Gompertz, one of the founders of the Royal SPCA in England, was a vegan who refused to ride in horse drawn conveyances. In 1824, he published a book in which he expressed a strong animal rights view.³ Another Englishman, Henry Salt, published the United States version of his book *Animals’ Rights Considered in Relation to Social Progress* in 1894. Salt, the founder of the Humanitarian League, said that rights “cannot be consistently awarded to men and denied to animals.” Salt and Gompertz attracted some attention to animal rights, but their works were largely forgotten by the mid-20th century.

The modern animal rights movement, as distinguished from the earlier animal welfare and anti-cruelty movements, started in the 1960s. It was ignited by novelist Brigid Brophy, who wrote an influential article called *The Rights of Animals* that was published in the *Sunday Times* in Great Britain in 1965. Although the title of Brophy’s article was the same as the title of Daggett’s 1791 speech, her thesis was very different. Brophy made an analogy to human slavery and argued that we do not have the right to use or kill animals for our own purposes. Her thesis was adopted and elaborated by a group of philosophers associated with the University of Oxford, who rediscovered the ideas expressed by 19th century animal rights advocates like Gompertz and Salt.

In 1975, Peter Singer’s book *Animal Liberation* provided an extensive philosophical analysis of the use of animals by humans, and attracted considerable attention.⁴ A few years later, in 1983, philosopher Tom Regan published a comprehensive and highly influential statement of animal rights in his book *The*

¹ See, e.g., Stephen Zawistowski, *Companion Animals in Society* (Clifton Park, NY: Thomson Delmar Learning, 2008), 88.

² Herman Daggett, “The Rights of Animals” (commencement address, Rhode Island College, September 7, 1791).

³ Lewis Gompertz, *Moral Inquiries on the Situation of Man and of Brutes* (1824).

⁴ Peter Singer, *Animal Liberation: A New Ethics for Our Treatment of Animals* (New York: Random House/New York Review, 1975).

*Case for Animal Rights.*⁵ Animal rights remained a fringe concept for years to come, however. Today a belief in animal rights is no longer seen as outlandish, although progress toward legal recognition of rights held by animals has been slow.

The animal rights movement in the latter decades of the 20th century concentrated on opposing the use of animals for food, clothing, and laboratory experiments, and paid little attention to the municipal animal shelters that occupied so much of the attention of humane organizations. Singer felt that humane organizations had gravitated to the care of stray dogs and protecting wild animals as “safe” subjects that would not threaten their status, while failing to take meaningful steps on the more controversial issues of the treatment of laboratory and farm animals.⁶ And although as many as 20 million dogs and cats were killed in shelters in 1970, the number of laboratory animals used that same year was over 50 million⁷ and the number of food animals killed in 1970 was estimated at 3.2 billion.⁸ Many cats and dogs suffered in animal shelters, but the suffering of a typical animal used in laboratory experiments or raised in close confinement on a factory farm and then shipped to slaughter was arguably far worse.

Another reason for the lack of attention paid by the late 20th century animal rights movement to shelter animals might have been the fact that the killing of animals in shelters lacked an obvious solution. Alternatives to laboratory tests on animals were starting to come into use in the 1980s.⁹ And we knew that humans did not require meat in their diet to be healthy. Thus, it was possible for animal rights advocates to make compelling arguments that we should simply stop using animals for laboratory experiments and food.

Pet overpopulation was still a reality in the 1980s, and people feared that without shelter “euthanasia” millions of cats and dogs would be left to suffer and die on the streets each year.¹⁰ Regan was one of the few animal rights advocates to grapple with the problem of shelter killing in the 1980s, but he was unable to suggest an immediate solution.¹¹ When animal rights advocates did think about companion animals, they sometimes concluded that the entire institution of ownership of companion animals was ethically wrong because it was exploitation of the animals.

Ed Duvin published a newsletter called *animalines* that he started in 1979. Most of his *animalines* essays dealt with the environmental movement and the use of animals by industry and agribusiness.¹² His essays were grounded in classical philosophy and ethics, but were very readable and appealed to a wide audience. He combined an uncompromising view of animal rights with a pragmatic understanding of the social and economic factors that kept people from facing the evils of society’s treatment of animals.

In 1985, the head of the Humane Society of the United States (HSUS), John Hoyt, offered Duvin the directorship of a new HSUS offshoot designed to build bridges from the animal protection community to the

⁵ Tom Regan, *The Case for Animal Rights* (1983; repr., Berkeley: University of California Press, 1985).

⁶ Singer, *Animal Liberation*, 241–245.

⁷ Andrew Rowan, *Of Mice, Models, and Men: A Critical Evaluation of Animal Research* (Albany: State University of New York Press, 1984), 65.

⁸ “Farm Animal Statistics: Slaughter Totals,” *Humane Society of the United States*, accessed April 28, 2017, http://www.humanesociety.org/news/resources/research/stats_slaughter_totals.html.

⁹ Martin Stephens, Alan Goldberg, and Andrew Rowan, “The First Forty Years of the Alternatives Approach: Refining, Reducing, and Replacing the Use of Laboratory Animals,” in *The State of the Animals: 2001*, ed. Deborah Salem and Andrew Rowan (Washington, DC: Humane Society Press, 2001), 127–134.

¹⁰ Some animal rights advocates supported spay-neuter campaigns, as shown by the fact that the International Society for Animal Rights was the sponsor of an important conference in Washington, DC, in September of 1991 on spay-neuter efforts. International Society for Animal Rights, *Special Report: Killing the Crisis, Not the Animals* (Clarks Summit, PA: International Society for Animal Rights, 1991). Spay-neuter campaigns did not become identified with animal rights, though, perhaps because they were focused on controlling the number of pets rather than on their right to have their lives respected.

¹¹ See chapter 18.

¹² Duvin also worked on civil rights, child abuse, and anti-poverty issues. His environmental work included overpopulation, world hunger, and biodiversity. In animal rights, as he put it, “there’s hardly an area I wasn’t involved in at one time or another over my 37 years.” He consulted with many non-profit organizations on management and conflict-resolution issues, and did presentations at conferences and symposiums.

animal rights and environmental communities.¹³ Duvin was hesitant at first, but agreed to the idea once he was assured that the institute would be independent, with its own board of directors and bylaws.¹⁴ The institute, which was named the Center for the Respect of Life and Environment, began work in 1986.¹⁵ As Duvin described it: “The Center’s focus was the morality of human interactions with animals, seeking the most effective methods of engendering a more compassionate ethos for our animal family and the environment.”¹⁶ Duvin continued to publish *animalines* while he directed the Center.

Duvin believed that the humane movement in the United States had lost its way and failed to keep pace with changing ideas about how humans should regard animals. In one of his *animalines* essays from the mid-1980s, *Hello Out There*, he pointed out that foundational humane leaders from the post-Civil War era such as Henry Bergh and George Angell used operative words like “mercy” and “humane treatment,” and they did not have “today’s vocabulary of ‘inherent rights’ and ‘equal consideration’ at their disposal.”¹⁷ And while Duvin found it understandable that the large humane organizations had in the past limited their concern for animals to preventing cruelty, he thought that in the 1980s, their “cautious posture” was a reflection of ossification. He urged the national humane organizations to be “willing to take creative risks and damn the organizational consequences.”

In December 1987, Duvin wrote an essay called *Status Quo Blues*, in which he applied his indictment of the national humane movement to animal shelters, arguing that SPCAs and humane societies throughout the country had “transformed complacency into an art form.”¹⁸ Referring to the “assembly line of slaughter” of dogs and cats in shelters, he ascribed it to “our own lack of innovation and boldness.” He argued that shelters must transform themselves into organizations that used “enlightened advocacy” and “creative risk-taking.”

In November 1988, Duvin set out a more specific critique of shelter killing in an essay called *Easy Come, Easy Go*. He observed that there was a “lamentable lack of exploration” of ways to change the situation of “18 million precious lives lost each year” in shelters.¹⁹ Instead of searching for ways to deal more effectively with pet overpopulation, shelters “smugly assert their primary responsibility is to prevent suffering rather than affirm the sanctity of every life—actually priding themselves on being ‘benign’ executioners.” Duvin argued that the shelter industry’s habit of using “euphemisms and subtle messages” about the reality and extent of shelter killing was preventing the public from “clearly understanding their role in producing the problem.”

¹³ Edward Duvin, email messages to author, March and April 2016; Bernard Unti, *Protecting All Animals: A Fifty-Year History of the Humane Society of the United States* (Washington, DC: Humane Society Press, 2004), 31.

¹⁴ Duvin, email messages.

¹⁵ *Ibid.* The Center was registered as a corporation in the District of Columbia in 1986.

¹⁶ Duvin, email messages.

¹⁷ Edward Duvin, “Hello Out There,” *animalines* 3, no. 1 (undated).

¹⁸ Edward Duvin, “Status Quo Blues,” *animalines* 4, no. 1 (December 1987).

¹⁹ Edward Duvin, “Easy Come, Easy Go,” *animalines* 4, no. 6 (November 1988).



Figure 60:
The *animalines* newsletter containing “In the Name of Mercy” was published in late 1989. From the author’s collection.

A year later, in late 1989, Duvin published *In the Name of Mercy*, by far his most influential essay.²⁰ He had interviewed many shelter directors and workers in the months before writing *Mercy* and had studied shelter operations, and was not impressed with what he had seen. He noted in *Mercy* that “in most communities across the country,” animal shelters “represent the sole voice for other beings, a voice that is often inaudible.”²¹ The shelter industry did not have accurate national statistics, which were “an indispensable element in developing, evaluating, and refining effective policies.” As a result: “It’s evident that the shelter community either doesn’t know enough or care enough to meet even the most marginal professional standards.”

Duvin elaborated in *Mercy* on a point he had made in *Easy Come, Easy Go* that the shelter establishment was wrong in believing that killing was a kindness. “Although euthanasia cannot be completely avoided at the present time, it borders on the obscene to describe the killing of many millions of innocent and healthy beings as a merciful act.” He noted that shelters justified the killing by arguing that they were merely

caretakers, and that “irresponsible pet owners” were to blame. He found those justifications “not only self-serving, but preposterous on the face of it” given the deficient management and operational practices of even the wealthiest shelters. Duvin acknowledged that “the public is not an innocent bystander,” but faulted shelters for their failure to reach out to the public and educate people about what was happening in shelters.

Drawing on his background as a non-profit consultant, Duvin made specific proposals for shelter reform in *Mercy*, including recruiting volunteers: “Were shelters to place a high priority in this area through attracting, training, and skillfully utilizing a volunteer outreach corps, they could begin the transition from a killing site to a community resource center.” He was not blind to the difficulties that shelter workers faced, stating that “shelter personnel work in the trenches and are often overwhelmed by the daily operational pressures of coping with overpopulation.” Shelters could only change, though, by “categorically rejecting the prevailing shelter value system” and beginning to “hold themselves accountable for meeting demanding performance standards that preserve life—not destroy it.” In words that could stand as a summary of the No Kill philosophy today, Duvin said: “A true shelter should be a place where life is affirmed, both in teaching and practice, not a building permeated with the odor of death.”

Although Duvin made specific suggestions for reform in *Mercy*, his main purpose in writing the essay was to start a movement to change the way shelters operated. The direction of that change would depend on how the movement developed. As he said: “My preeminent goal was to pen a sweeping ‘indictment’ of

²⁰ Edward Duvin, “In the Name of Mercy,” *animalines* 4, no. 11 (undated).

²¹ Duvin, “In the Name of Mercy.”

prevailing shelter practices—thereby creating a foundation for a new ethos for homeless animals. My conviction was if I could indelibly stigmatize ‘killing them kindly’ as an acceptable means of population control, an alternative movement would axiomatically follow. I predicated that assumption on the historical dynamics of social change, as before a new movement can take hold, the current cultural norm has to be exposed to scrutiny and found morally lacking.”²²

So many people requested copies of *Mercy* that two additional printings were required to meet the demand.²³ In addition, hundreds of people requested permission to reprint the essay. Duvin received thousands of responses to *Mercy* from people in the United States and foreign countries. Reaction to the essay was sharply divided. About 80% of the communications Duvin received were positive and 20% were negative, “often vitriolic in the extreme.” Rescuers, grassroots activists, and the general public reacted very positively to the essay, while shelter workers “who had been indoctrinated in the ‘killing-them-kindly’ mindset,” as Duvin put it, were appalled. One shelter worker wrote a 10-page letter accusing Duvin of caring more about his principles than about homeless animals starving in the streets.

Not everyone in the animal shelter establishment rejected *Mercy* outright. Two state humane associations, the Oregon Animal Welfare Alliance and the Virginia Federation of Humane Societies, distributed copies to each of their members.²⁴ Duvin spoke to many humane-society boards, and noticed that younger board members tended to favor the thesis of *Mercy* while older board members “saw me as the devil incarnate.” He received a telephone call from a shelter worker who told him, in tears, that he had killed over 50,000 animals in his career, and when he attended conferences, they had taught him only how to kill animals more humanely, not how to stop the killing.

In a follow-up essay called *Benign Neglect*, issued two months after the publication of *Mercy*, Duvin urged the animal-rights movement to become more involved in animal shelter issues, specifically by doing grassroots organizing to end pet overpopulation.²⁵ He characterized this as a relatively easy issue for animal rights advocates to address because there were “few powerful adversaries and over 100 million companion animals residing in homes.” For Duvin, who was accustomed to confronting the agribusiness, fur, and research industries, the opposition to shelter reform did not seem daunting. It was difficult to see how anyone could oppose shelter reforms that would save the lives of companion animals.

Duvin resigned from the Center for the Respect of Life and Environment early in 1990 because he wanted to work full-time on capturing the momentum of the positive reaction to *Mercy*.²⁶ As he said: “The quantity and content of the responses I received from here and abroad indicated this was a moment in history that had to be seized.” Duvin formed a new organization called Project Zero to work on reducing pet overpopulation. This organization was a loose network of about 500 people who were interested in actively furthering the vision of No Kill. For the next five years, Duvin continued to devote his time to advocating for No Kill.

One article he wrote during this period, called “*Speciesism: Alive and Well*,” appeared in 1992 in the *Animal’s Voice*, an animal rights magazine.²⁷ Duvin believed it was important to educate the public about what was going on in animal shelters, and the article was illustrated with photographs of barrels full of the

²² Duvin, email messages.

²³ Ibid.

²⁴ Edward Duvin, “Benign Neglect,” *animalines* 4, no. 12 (undated); Duvin, email messages.

²⁵ Duvin, “Benign Neglect.”

²⁶ Duvin, email messages. Duvin states that he resigned from HSUS “without any pressure whatsoever” and that “John [Hoyt] honored his commitment of total independence without any exceptions, including ‘Mercy.’”

²⁷ Edward Duvin, “Speciesism: Alive and Well,” *Animals’ Voice* 5, no. 4 (January/February/March 1992).

bodies of animals who had been killed in a shelter. Duvin argued in *Speciesism* that humane organizations should refuse to participate in killing healthy animals. He urged activists to: “Protest, petition, do whatever you can to pressure *status quo* humane societies and SPCAs to say, “Enough! We categorically reject the practice of loving our friends to death.” Only then, he thought, would communities be compelled to take whatever steps were necessary to stop the killing. In a panel discussion in 1997, Duvin emphasized the importance of humane organizations renouncing their animal control contracts, arguing that the unreimbursed costs and responsibilities associated with animal control were so overwhelming that it impeded humane societies and SPCAs from working on fundamental causes of pet overpopulation.²⁸

Speciesism once again addressed the theme Duvin had discussed in *Mercy*—that shelter personnel err when they maintain that killing is a kindness because it prevents suffering.²⁹ He elaborated that “the salient issue is not suffering, but a deadly form of human ignorance that presumes ‘killing them kindly’ is preferable to what we all face: a life fraught with uncertainties, grave risks, and anguish.” Duvin made an analogy to children living in substandard orphanages, and refugees living in overcrowded camps, and noted that what we seek to do in those cases is improve the conditions, not kill the victims. He pointed out that feral cats had also been caught up in the “killing is a kindness” mindset, and decried the arrogance of “presuming that certain death is a kinder fate for ferals than an uncertain life.”

One of Duvin’s greatest contributions, starting with *Hello Out There* and *Status Quo Blues* and continuing in *Mercy* and *Speciesism*, was his identification of animal welfare versus animal rights as the central philosophical difference between the traditional shelter industry and the new paradigm he envisioned. The non-profit sector of the traditional shelter industry was led in large part by “legacy” humane associations that had been in existence for decades, and in some cases for more than a hundred years. They operated on an animal-welfare philosophy—“for the prevention of cruelty” was enshrined in the very names of many of them. As Duvin noted, those organizations concentrated on humane treatment of shelter animals and did not generally concern themselves with whether it was ethical to kill them.

Duvin argued that the belief of the traditional shelter industry that “homeless equals suffering equals killing equals kindness” was an “animal welfarist” mentality that had become ingrained in the shelter industry in the days before the animal rights movement had “articulated the ‘rights’ of nonhumans.” Under an animal rights view, shelter animals had a right to live, not just a right to be free of suffering. This represented a profound break with the past. Since the first animal shelter was founded in 1870, humane organizations had accepted killing of “excess” animals as not only justified but humane.³⁰

The animal welfare movement in the period from 1866 to 1920 had focused on stopping cruelty to animals, which was common and largely unremarkable in those days. Humane societies and SPCAs saw their mission as preventing suffering rather than preserving animal life. When Henry Bergh was criticized in the 1870s for not working to stop the killing of dogs at the New York City pound, he reportedly responded: “It does not necessarily follow that there is cruelty in taking animal life; otherwise the butcher exposes himself to this charge, and all who eat flesh are to a certain extent, accomplices.”³¹ More than a century later, the city pounds and legacy humane associations that killed millions of cats and dogs in shelters every year were merely reflecting the historical view of animal welfare that to cause an animal to suffer needlessly was wrong, but to kill an animal was not wrong as long as the killing was painless and done for a nontrivial purpose.

²⁸ “The Role of Animal Shelters,” *Animals’ Agenda*, March-April 1997, 41–42.

²⁹ Duvin, “Speciesism.”

³⁰ Zawistowski, *Companion Animals in Society*, 88.

³¹ C. C. Buel, “Henry Bergh and His Work,” *Scribner’s Monthly* 17, no. 6 (April 1879): 880.

Some ethicists argued against the concept of an animal's right to live by asserting that future life had no value to an animal.³² They argued that animals could not conceive of the future and, therefore, would not experience any loss by being deprived of future life. Thus, there was no ethical requirement to do anything more for animals than meet their present needs. This welfarist approach was typified by a concept called the "five freedoms," which was originally designed to apply to farm animals but was adapted for animal care in many other contexts, including animal shelters.³³ The five freedoms are (1) freedom from hunger and thirst, (2) freedom from discomfort, (3) freedom from pain, injury or disease, (4) freedom to express normal behavior, and (5) freedom from fear and distress. Notably absent from this list is the freedom to live.

Duvin's refutation of the "killing is a kindness" rationale for shelter killing, his call for humane societies and SPCAs to get out of the business of killing, his argument that animal rights should replace animal welfare as the operating principle of humane organizations, and his view of the animal shelter of the future as a life-affirming community center became key components of the nascent No Kill movement. Duvin did not argue that it was possible in the 1980s or early 1990s to immediately stop shelter killing. His argument was that humane organizations and the animal-shelter industry, instead of rationalizing shelter killing as a kindness, must fully recognize shelter killing as a moral evil. The recognition of this moral evil, he believed, would spur people to make whatever changes were needed to bring an end to the killing.

Duvin's essays, particularly *Mercy*, crystallized an inchoate feeling that had been growing in many people who sensed that the current sheltering system in the United States was ethically flawed. His presentation of the philosophical arguments in a way that everyone could understand helped people break free of the animal welfare approach that had monolithically governed animal sheltering since 1870. The next chapter describes how a grassroots movement for a new type of sheltering grounded in a belief in the value of the life of each individual animal arose in the early 1990s.

³² This view was criticized by Regan. Regan, *The Case for Animal Rights*, 99–103.

³³ "Farm Animal Welfare Council: Five Freedoms," *The National Archives*, <http://webarchive.nationalarchives.gov.uk/20121007104210/http://www.fawc.org.uk/freedoms.htm>.

Chapter 20: Organizing the Grassroots

Edward Duvin's 1989 essay *In the Name of Mercy*, discussed in the last chapter, argued that humane organizations that were operating animal shelters and killing healthy animals were betraying the animals they purported to serve. By 1989, there were several private shelters and rescues that had dissociated themselves from killing healthy animals, and a few public shelters, described in Part V, were developing programs and models to raise the number of animals they released alive. This surge of interest in shelter lifesaving in the 1970s and 1980s and the wide readership that *Mercy* attracted showed that No Kill had considerable support by 1990 and was ripe to become a movement.

The Best Friends Animal Society was one of the first national organizations to become involved in the growth of a grassroots No Kill movement. Best Friends was originally registered as a non-profit corporation in Louisiana in 1968 under a different name. It went through a number of iterations of name and mission before its founders established a permanent home on a plot of about 3,300 acres in Kane County, Utah, in 1984.¹ Several of the founders had been involved in rescuing animals from shelters in Arizona in the 1970s and early 1980s, and their intention in relocating to Utah was to build a large sanctuary for homeless animals.² When they moved to Utah, they had about 200 dogs and cats.³ Best Friends now owns almost 3,700 acres and leases an additional 17,000 acres from the Bureau of Land Management.⁴



Figure 61:
Kane County, Utah lies along the border with Arizona. Photograph by Ken Lund, licensed under CC BY-SA 2.0.

The Utah property was undeveloped, and one of the first orders of business was to build housing for the humans and animals.⁵ The founders of Best Friends were familiar with the corridor-style housing used for dogs in most animal shelters at the time, where rows of individual runs opened onto walkways.⁶ Since some of the animals they would be taking in at their sanctuary would be long-term residents, they looked for an alternative style of housing that could provide a better quality of life.

¹ Francis Battista, interview by author, September 22, 2014, and e-mail message to author, February 26, 2017.

² Battista, interview; Gregory Castle, interview by author, March 6, 2015.

³ Battista, interview.

⁴ "Answers to Questions About Our Sanctuary, Programs, and Outreach Work," *Best Friends Animal Society*, accessed March 24, 2017, <http://bestfriends.org/about/faqs>; Battista, email message.

⁵ Gregory Castle, "Breaking Ground at Best Friends," *Best Friends Blog*, February 19, 2014, <http://blogs.bestfriends.org/index.php/2014/02/19/breaking-ground-at-best-friends/>.

⁶ Faith Maloney, interview by author, March 10, 2014.

Faith Maloney, one of the founders of Best Friends, had previous experience running a sanctuary and she was interested in using group housing.⁷ She had visited a sanctuary in California called Living Free that used large octagon shaped buildings to house dogs, and she adapted that style of building for the Best Friends sanctuary. She also developed congregate housing for cats. Not all dogs and cats were happy in group housing, and those animals were provided with individual rooms. For most animals, though, Maloney found that group housing kept them happy and healthy and avoided the stress often seen in dogs and cats kept in standard shelter housing.

The founders of Best Friends soon discovered that homeless animals in Kane County and its county seat, the town of Kanab, were not receiving good care from the municipal shelter.⁸ In fact, the “shelter” was just a tin roofed shed in a field. A veterinarian came once a week to kill any animals who had not been reclaimed. In the meantime, some animals died from lack of care. Francis Battista, one of the founders of Best Friends, got permission from the town’s mayor for the group to take over animal care and control for the town and county, and for several years Faith Maloney was the unofficial animal control officer. Best Friends also took in owner-surrendered dogs and cats from the area.

Most of the animal control calls they received about cats were complaints about feral or community cats creating a nuisance. They trapped the cats and took them to the sanctuary. To house feral cats, they created Wildcat Village, which had shelters within an outdoor enclosure. The Best Friends sanctuary was in a desert region, and feral cats there did not tend to form the type of colonies that are sometimes seen in areas with ample shelter and food sources. Predators were also an issue in the area, so returning the cats to their territory was usually not an option.

By the late 1980s, the Best Friends sanctuary had close to 1,500 animals, mostly from owner surrenders and animal control operations in Kane County and Kanab.⁹ The Best Friends founders had always done adoptions in connection with their shelter work, so they began to make trips to Las Vegas, Salt Lake City, and smaller communities in the region to adopt out animals. On one occasion, they sent 18 cats to the San Francisco SPCA (SF/SPCA) and in return received one large dog named Bryson who needed behavior rehabilitation.¹⁰ Demand for cats was high in San Francisco due to the numerous apartments in the city, whereas demand for large dogs was low because many landlords banned them. Best Friends could easily deal with Bryson, but it was hard for them to find homes for cats. So the arrangement suited everyone.

The Best Friends founders realized around 1991 that they needed to become more effective at fundraising if they were going to be able to survive and expand.¹¹ They decided to raise money by setting up tables in various cities, primarily in the southwest but also as far away as Seattle and Denver. They told people what they were doing and asked for donations. Battista began making trips to Los Angeles to table, and Gregory Castle, another of the founders, began tabling in Salt Lake City. The trips continued for several years.

The staff of Best Friends started tabling with the intent of raising money, but their visits to other communities gradually grew into an effort to help local rescuers save animals from their city shelters.¹² They met people in each city who worked at local shelters, volunteered, and did fostering. They learned where the biggest

⁷ Ibid.

⁸ Battista, interview.

⁹ Ibid.

¹⁰ Michael Mountain, interview by author, January 21, 2014.

¹¹ Battista, interview; Castle, interview.

¹² Castle, interview.

problem areas were and how people were dealing with situations in the various cities. They wanted to help where they could and so they began networking, using a fax machine to distribute lists of adoptable animals.

In 1992, Best Friends began doing seminars at the Utah sanctuary to teach people how to set up their own sanctuary.¹³ They also began to publish a magazine. The first few issues were rudimentary, but it quickly took on a more professional look. The magazine expressed Best Friends' underlying philosophy that homeless pets should be able to live their lives. Michael Mountain, the president of Best Friends for many years, was struck by the number of letters they received from people who said something like: "Dear Best Friends, I thought I was the only person who felt this way. Now I know I'm not."¹⁴

The Best Friends magazine was primarily focused on the positive message of what was happening at the Utah sanctuary. They turned animal residents of the sanctuary into characters who had their own storylines, such as Tomato the cat who was an investigative reporter and conspiracy theorist.¹⁵ The Best Friends founders believed that their outreach was effective because their message, in contrast to the messaging from many shelters in those years, was "unfailingly positive" about the animals the sanctuary had helped.¹⁶

By 1994, Best Friends was doing collaborative adoption events with small organizations in the various cities they visited.¹⁷ As they became accustomed to organizing these events, they developed a routine where they would arrange for a venue in a shopping mall or similar space, contact the media, and do the setup for the event. All the local organizations had to do was bring their animals. By the late 1990s, Best Friends was organizing weekend events with 400 to 500 animals and 25 to 50 participating rescues and shelters.



Figure 62:
Lynda Foro. From author's collection.

Another important influence on the nascent grassroots No Kill movement in the 1990s was the *Animal People* newsmagazine, established in 1992 by Kim Bartlett and Merritt Clifton. Bartlett and Clifton were early No Kill advocates, and *Animal People* reported in depth on the No Kill movement as it grew. *Animal People* provided a counterweight to the traditional shelter industry by featuring stories that showed the accomplishments of North Shore and the SF/SPCA. It was the major source of reporting on the No Kill movement in the 1990s.¹⁸

The No Kill movement was given structure in the mid-1990s through the work of Lynda Foro, an Arizona resident who had training in non-profit management. She decided that she wanted to promote No Kill after visiting the Best Friends sanctuary in 1992 and 1993.¹⁹ Foro learned on those visits about the growing number of people across the country who were operating private No Kill shelters and rescues.

At that time, existing No Kill shelters were geographically isolated from each other and often were not welcomed by their

¹³ Battista, interview.

¹⁴ Mountain, interview.

¹⁵ Ibid.

¹⁶ Battista, interview.

¹⁷ Castle, interview.

¹⁸ Bonney Brown, interview by author, March 9, 2016.

¹⁹ Lynda Foro, "The History of the No-Kill Movement" (2001), *Maddie's Fund*, accessed March 25, 2017, <http://www.maddiesfund.org/the-history-of-the-no-kill-movement.htm?p=topic37>.

neighboring traditional shelters.²⁰ Foro realized that No Kill was being held back because, as she said, “there was no communication device among practitioners of no kill,” even though “there was a crying need for information and resources to be shared to help the animals in their care.”²¹ In March of 1994, she founded an organization called Doing Things for Animals.²² The goal of Doing Things for Animals was to help No Kill advocates and organizations network so that they could transform the United States into a country where healthy and treatable homeless animals were not killed.²³

Foro’s first project was the creation of a No Kill Directory. She sent out almost 500 questionnaires to sanctuaries and rescues that she had identified from various sources, including telephone books, referrals, and an advertisement she placed in *Animal People*.²⁴ The questionnaire asked if a “non-euthanizing” policy was in effect, and those who replied in the affirmative were listed. The first No Kill Directory was published in 1994 and listed 111 organizations in 33 states, including Best Friends, the SF/SPCA, Operation Kindness, Farm Sanctuary, and Tree House Animal Foundation.²⁵ The directory sold out two printings within weeks.²⁶

The rapid growth of interest in No Kill was shown by the fact that most of the organizations that qualified for a listing in the 1994 directory had been established within the previous 12 years.²⁷ Merritt Clifton presciently noted in a 1994 article about the directory that the number of No Kill organizations might expand rapidly in the next decade as organizations took advantage of the fact that the spay-neuter movement had reduced shelter intake.²⁸

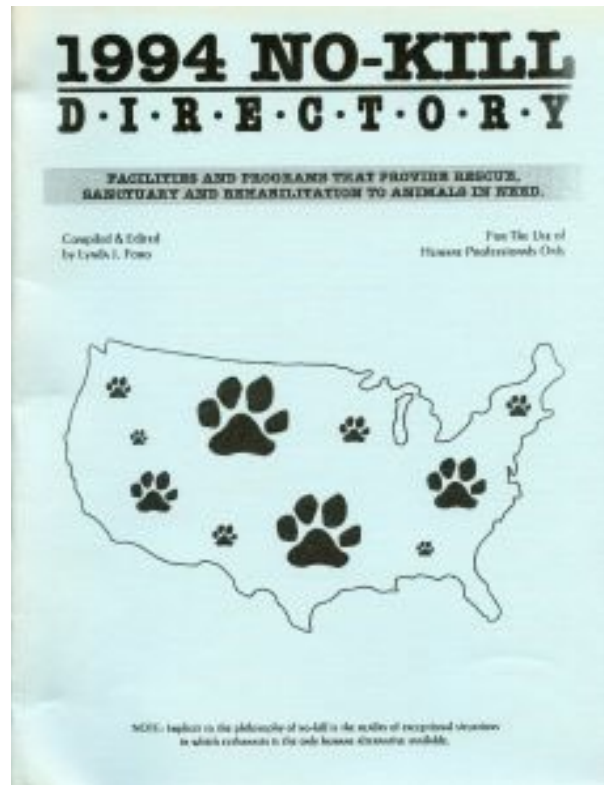

Figure 63:
Cover of Foro’s first No Kill Directory. From author’s collection.

Foro published four editions of the No Kill Directory, in 1994, 1995, 1996 to 1997, and 1998. The number of listings steadily increased, to 180 for the 1995 directory, 249 for the 1996 to 1997 directory, and 390 for the 1998 directory.²⁹ Organizations that had joined the list by 1998 included Alley Cat Allies, Berkeley-East Bay Humane Society, Ellen M. Gifford Sheltering Home, Fund for Animals Black Beauty Ranch, Helen Woodward Animal Center, North Shore Animal League, Northeast Animal Shelter, Progressive Animal Welfare Society, and Ryerss Farm for Aged

²⁰ Lynda Foro, “Know the Thrill of No Kill—Retreat, Hell!,” *Foro for Animals*, Internet Archive, <https://web.archive.org/web/20030209203509/http://foroforanimals.org/PAGES/articles/articles.html>.

²¹ Foro, “History of the No-Kill Movement.”

²² Doing Things for Animals was incorporated in Arizona on March 28, 1994.

²³ Ellen Perry Berkeley, “No-Kill Agenda,” *Cats*, February 1998, 22; Lynda Foro, interview by author, January 3, 2014.

²⁴ Lynda Foro, ed., *1994 No-Kill Directory* (Glendale, AZ: Doing Things for Animals, 1994), inside front cover.

²⁵ *Ibid.*

²⁶ Lynda Foro, ed., *1995 No-Kill Directory* (Glendale, AZ: Doing Things for Animals, 1995), inside front cover.

²⁷ Merritt Clifton, “Getting A Leash on No-Kills,” *Animal People*, April 1994.

²⁸ *Ibid.*

²⁹ Lynda Foro, “Doing Things for Animals, Chronology of Events,” undated.

Equines.³⁰ A few foreign organizations were listed. The majority of listings were small, grassroots rescues and shelters, but large humane societies were also represented.

The success of the 1994 directory convinced Foro that there was sufficient interest in No Kill to justify a national conference, and as she planned the 1995 directory, she also planned a conference.³¹ At that time, No Kill advocates had little or no opportunity to speak at conferences held by the traditional shelter establishment, where the reaction to them was often hostile.³² Foro's first conference, a one-day retreat called "No Kills in the 90's," was held in Phoenix in September 1995.³³ Foro issued an open invitation to humane organizations and animal caregivers, and she was pleased that both No Kill supporters and traditional shelter officials were present at the conference.³⁴ The conference was sponsored by North Shore Animal League and the Pet Savers Foundation, and 75 people attended.³⁵ Merritt Clifton of *Animal People* and SF/SPCA president Richard Avanzino were featured speakers.³⁶ Faith Maloney and Cyrus Mejia represented Best Friends.³⁷

The 1995 conference attracted the attention of Edwin Sayres, who was director of the Animal Protection Division of the American Humane Association (AHA) at the time. He arranged with Foro for the AHA to cohost the 1996 conference.³⁸ He felt that it would be valuable for AHA members, who were largely part of the traditional shelter establishment, to have the opportunity to learn more about the new No Kill movement.³⁹ The 1996 conference was held on September 7th and 8th in Denver, where the AHA headquarters was located.⁴⁰

The 1996 conference was designed as a "gathering of alternatives" where attendees would learn to "establish working relationships with every kind of animal service group in [the] community."⁴¹ Presenters included Foro, Clifton, Bartlett, Maloney, and Avanzino, as well as Michael Arms from North Shore Animal League and Bonney Brown, the founder and director of the Neponset Valley Humane Society (NVHS) in Massachusetts. Topics included transitioning shelters to No Kill, dealing with feral cats, how to increase adoptions, fundraising, how to run a volunteer program, shelter housing, and veterinary practices for long-term shelter care. About 125 people attended.⁴²

³⁰ Lynda Foro, ed., *1998 No-Kill Directory* (Sun City, AZ: Doing Things for Animals, 1998).

³¹ Foro, "Know the Thrill of No Kill."

³² Ibid.

³³ Foro, "History of the No-Kill Movement."

³⁴ Ibid.

³⁵ Foro, "Doing Things for Animals, Chronology of Events."

³⁶ Merritt Clifton, "No-Kill Success and Fiscal Reality Collide in Reno," editorial, *Animal People*, 2002; Merritt Clifton, "What's in a Name? No-Kills and the Heart of Darkness," *Animal People*, April 1997; Merritt Clifton, email message to author, January 28, 2014.

³⁷ Maloney, interview.

³⁸ Foro, "Know the Thrill of No Kill."

³⁹ Edwin Sayres, interviews by author, February 28, 2014, and August 3, 2014.

⁴⁰ American Humane Association and Doing Things for Animals, *No-Kills in '96: Promoting Unity in the Humane Community* (Denver, CO: American Humane Association, 1996).

⁴¹ Ibid.

⁴² Foro, "History of the No-Kill Movement."

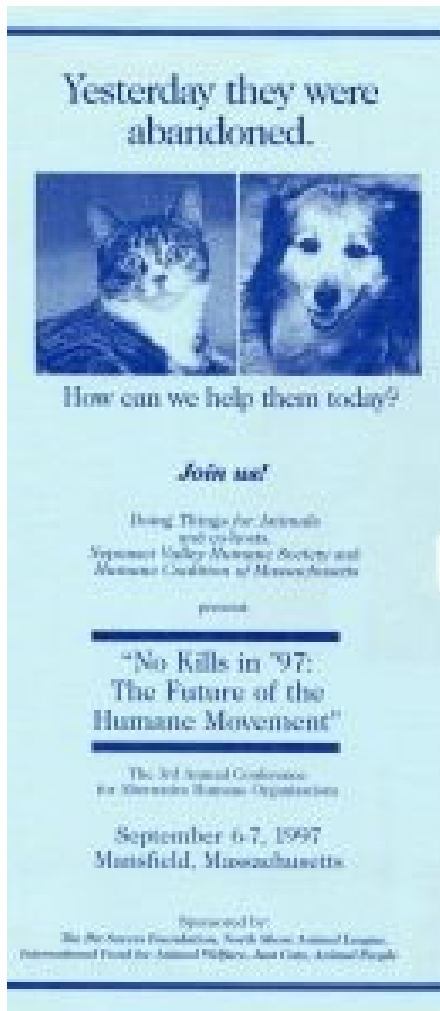

Figure 64:
Brochure for Foro's 1997 conference. From author's collection..

A recurring topic at Foro's early conferences was the meaning of "No Kill." People from the traditional shelter industry would frequently tell Foro that No Kill was impractical because there were situations where euthanasia was the only humane option, such as when an animal was suffering and could not be treated.⁴³ This issue came up in a workshop at the 1996 conference when someone asked if "no means no."⁴⁴ The answer was that the term "No Kill" was designed to emphasize the distinction between killing a healthy or treatable animal and euthanizing an animal who was suffering and could not be treated. No Kill did not mean no euthanasia, but No Kill shelters restricted the use of the term "euthanasia" to untreatable and vicious animals. Causing the death of a healthy or treatable animal was not "euthanasia," it was just killing. Foro received this question so many times that she put the following notice on the front cover of each of her directories: "Note: Implicit to the 'No Kill' philosophy is the reality of exceptional situations in which euthanasia is the most humane alternative available."

Bonney Brown became the vice-president of Doing Things for Animals in June 1997,⁴⁵ and she arranged for its 1997 conference to be cohosted by NVHS and the Humane Coalition of Massachusetts.⁴⁶ The conference, "No Kills in '97: The Future of the Humane Movement," was held in Mansfield, Massachusetts, on September 6th and 7th.⁴⁷ The Humane Coalition of Massachusetts presented Foro with its first Humane Achievement Award at the conference.⁴⁸ Foro's 1997 conference was the first No Kill conference held on the east coast. It had more than double the attendance of 1996, with 300 people signing up and more having to be turned away.⁴⁹ Its success signified that No Kill had become a national movement. Best Friends also had a significant national presence by 1997. It had about 100,000 active members (including volunteers and

contributors) from all over the United States.⁵⁰

People attended Foro's conferences for a variety of reasons. Board members of a New England shelter who attended the 1997 conference, for example, were looking for ways to reduce their kill rate, which was

⁴³ Sayres, interviews.

⁴⁴ Ibid.

⁴⁵ "Profile of the People Who Are Doing Things for Animals, Inc.," in *1998 No-Kill Directory*, ed. Lynda Foro (Sun City, AZ: Doing Things for Animals, 1998).

⁴⁶ Brown, interview; Doing Things for Animals, *No-Kills in '97: The Future of the Humane Movement* (Canton, MA: Neponset Valley Humane Society, 1997). Sponsors for the 1997 conference included Pet Savers Foundation, North Shore Animal League, International Fund for Animal Welfare, Just Cats, and *Animal People*.

⁴⁷ Doing Things for Animals, *No-Kills in '97*.

⁴⁸ Foro, "Doing Things for Animals, Chronology of Events."

⁴⁹ Foro, "History of the No-Kill Movement"; Berkeley, "No-Kill Agenda," 22.

⁵⁰ "Frequently Asked Questions," *Best Friends Animal Sanctuary*, Internet Archive, <https://web.archive.org/web/19970209135712/http://www.bestfriends.org/BFFacts.html>.

808 out of 1836 animals taken in during 1996.⁵¹ Another attendee in 1997 was the director of a city shelter who wanted to get out of traditional sheltering and start a No Kill organization.⁵² By this time, Foro had identified non-profit management skills as “the weakest link” for the typical small No Kill organization, and she designed the conferences to help teach management skills.⁵³

The 1997 conference was noteworthy for its emphasis on feral cat issues, which were a prominent concern in the northeast. Alley Cat Allies held a “Focus on Ferals” one-day seminar on Friday, September 5th, in conjunction with the Doing Things for Animals conference on Saturday and Sunday.⁵⁴ Presenters included Alley Cat Allies founders Becky Robinson and Louise Holton and trap-neuter-return (TNR) pioneer AnnaBell Washburn.⁵⁵ The seminar attracted 120 people.⁵⁶ Feral cat advocates had a natural affinity with the No Kill movement because TNR was a lifesaving alternative for shelters that were impounding and killing feral cats. Ellen Perry Berkeley, an author and prominent feral cat advocate, attended the conference and wrote about it afterward for *Cats* magazine.⁵⁷

The 1997 conference included three featured speakers, as well as roundtable discussion groups, a No Kill leadership forum, and 24 workshops.⁵⁸ Foro led off the conference with a speech characterizing the No Kill movement as “the fastest growing contingent of caregivers in animal welfare,” saying: “Make no mistake, we are on the brink of a fulfilling future and we have a humane century ahead of us.”⁵⁹

One of the speakers at the 1997 conference was Craig Brestrup, author of *Disposable Animals: Ending the Tragedy of Throwaway Pets*.⁶⁰ In 1994, Brestrup had become the director of the non-profit Progressive Animal Welfare Society (PAWS) in Lynnwood, Washington, just north of Seattle.⁶¹ Before he took the job at PAWS, he had been the director of a community mental health center in California. He had studied and written about animal rights while he was obtaining a doctorate degree in medical humanities, but had done no hands-on work in animal sheltering before becoming director of PAWS.

PAWS, in 1994, had contracts for animal sheltering with several local communities, and accepted owner surrenders.⁶² It took in thousands of animals a year and killed them when it ran out of time or space to care for them. It was a very progressive organization in many ways though, with wildlife rehabilitation and animal rights divisions. Brestrup saw a disconnect between those progressive missions and the killing of healthy pets, and he began to research the issue, including reading Duvin’s work. Less than a year after he took over as director of PAWS, he wrote an essay about stopping the killing, which he distributed to the board and staff. That started a period of discussion which resulted in the board deciding to transition to No Kill by giving up its municipal contracts.⁶³

Brestrup argued in *Disposable Animals* that the way traditional shelters operated was encouraging people to place a low value on their pets. For more than a century, animal shelters had prided themselves on being

⁵¹ Berkeley, “No-Kill Agenda,” 22.

⁵² Ibid.

⁵³ Foro, “Know the Thrill of No Kill.”

⁵⁴ Alley Cat Allies, *Focus on Ferals* (Mount Ranier, MD: Alley Cat Allies, 1997).

⁵⁵ Ibid.

⁵⁶ Berkeley, “No-Kill Agenda,” 22.

⁵⁷ Ibid.

⁵⁸ Doing Things for Animals, *No-Kills in '97*.

⁵⁹ Humane Coalition of Massachusetts, “Looking Back on the ‘No-Kills in ‘97’ Conference,” *Humane Coalition News*, Winter 1998, 8.

⁶⁰ Craig Brestrup, *Disposable Animals: Ending the Tragedy of Throwaway Pets* (Leander, TX: Camino Bay Books, 1997).

⁶¹ Ibid.; Craig Brestrup, interview by author, January 24, 2014.

⁶² Brestrup, interview.

⁶³ Ibid.; Jennifer Bjorhus, “PAWS Switching to ‘No-Kill’ Shelter—Two Employees Will Resign in Protest,” *Seattle Times*, January 26, 1995.

places where an owner could drop off a pet at any time. Many shelters even provided “drop boxes” where people could leave animals when the shelter was closed. At the same time that shelter officials decried the “irresponsible public,” they were making it as easy as possible for people to give up their animals with no questions asked. As Brestrup put it in *Disposable Animals*: “Does an irresponsible public attune to what animal authorities do rather than to what they say?”⁶⁴ In his speech at the 1997 Doing Things for Animals conference, Brestrup emphasized that the growing grassroots No Kill movement could counter the idea that animals were disposable by forcefully arguing for an ethics-based approach to animal sheltering.⁶⁵

In 1998, the Doing Things for Animals conference returned to the western United States. The conference, “No Kills in ‘98—Building Bridges to a Humane Century,” was held on September 10th to 13th in Concord, California, about 30 miles from San Francisco, and was cohosted by the SF/SPCA.⁶⁶ It drew over 300 people, with 15% from humane societies and animal control organizations and 85% from No Kill groups.⁶⁷ It was the first No Kill conference to extend to four days, and on the last day field trips were offered to venues including the SF/SPCA.⁶⁸

The close look at San Francisco’s shelter system offered by the 1998 conference was important because it underlined the difference between “No Kill” as it applied to individual private shelters and “No Kill” as it applied to an entire city or county, including the public animal-control shelter. By 1998, there were several hundred individual private No Kill shelters in the United States,⁶⁹ but the concept of an entire No Kill city was still very new. The 1998 conference allowed its participants to see how the partnership between the SF/SPCA and the city animal control department worked.

Featured speakers at the 1998 conference included Richard Avanzino, who was soon to leave the SF/SPCA to take over Maddie’s Fund, and Michael Mountain, whose speech at the 1997 No Kill conference had been very well received.⁷⁰ The list of presenters for the 1998 conference included Bonney Brown, Merritt Clifton, Francis Battista, Gregory Castle, Ellen Perry Berkeley and Louise Holton.⁷¹ Doing Things for Animals presented animal rights advocate Edward Duvin with a special award for, as Bonney Brown put it in presenting the award, “lighting the spark” of the grassroots No Kill movement.

In 1999, Foro affiliated with the Pet Savers Foundation, a subsidiary of North Shore Animal League.⁷² She stopped publishing the No Kill Directory but continued to run Doing Things for Animals and host the No Kill conferences. The 1999 conference was held in Chicago from September 30th to October 3rd.⁷³ Attendance doubled to 600 people. The growing influence of the No Kill movement was shown by the wide variety of presenters at the conference, including Paula Fasseas, founder of PAWS Chicago, Julie Levy from the University of Florida College of Veterinary Medicine, Carter Luke of the Massachusetts SPCA, Esther Mechler of Spay/USA, and Gary Patronek of the Tufts Center for Animals and Public Policy.⁷⁴ No Kill was also becoming increasingly known to the world at large. Ellen Perry Berkeley noted in a 1999 article

⁶⁴ Brestrup, *Disposable Animals*, 31.

⁶⁵ Humane Coalition of Massachusetts, “Looking Back on the ‘No-Kills in ‘97’ Conference,” 11–12.

⁶⁶ Doing Things for Animals, *No Kills in ‘98—Building Bridges to a Humane Century* (Concord, CA: San Francisco SPCA, 1998); “Anti-Pet Euthanasia Conference Scheduled,” *San Francisco Chronicle*, September 1, 1998.

⁶⁷ Ellen Perry Berkeley, “Doing Great Things for Animals,” *I Love Cats*, July/August 1999, 30; Foro, “Doing Things for Animals, Chronology of Events.”

⁶⁸ Doing Things for Animals, *No Kills in ‘98*.

⁶⁹ Foro, *1998 No-Kill Directory*; Julie Dowling and Cynthia Stitely, “Animal Shelters Debate the Role of Euthanasia,” *HSUS News* 43, no.1 (1998): 22.

⁷⁰ Doing Things for Animals, *No Kills in ‘98*.

⁷¹ *Ibid.*

⁷² Foro, “Doing Things for Animals, Chronology of Events.”

⁷³ Lynda Foro, “Talk About Success,” *No Kill News*, Autumn 1999, 1.

⁷⁴ Doing Things for Animals, *1999 No-Kill Conference* (Sun City, AZ: Doing Things for Animals, 1999).

that No Kill was receiving considerable attention from the media and attracting substantial financial support.⁷⁵

The 2000 No Kill conference was in Tucson, Arizona, and drew over 600 attendees.⁷⁶ By this time, Foro was providing a large space for exhibits, and the networking aspect now included offering an opportunity for people to meet with others from their states. The 2001 conference, which took place in Hartford, Connecticut on August 16th to 19th, had about 1,000 attendees.⁷⁷

Foro left Pet Savers Foundation in 2002 and started a consulting service for animal care non-profit organizations. Pet Savers Foundation continued to put on conferences under the name of CHAMP (Conference on Homeless Animal Management and Policy), reaching out to a wider audience than the No Kill grassroots.⁷⁸ Meanwhile, Bonney Brown, who went to work for Best Friends in 1999, launched the Best Friends No More Homeless Pets conferences in 2001.⁷⁹ The Best Friends conferences continue today under the name Best Friends National Conference.

Foro maintained the animal rights character of the grassroots No Kill movement throughout her work with Doing Things for Animals, with a focus on the value of the life of the individual animal. She was a vegetarian, and served vegetarian meals at all the No Kill conferences and vegan meals at the later conferences.⁸⁰ *Animal People* characterized Foro's seven No Kill conferences from 1995 to 2001 as "transform[ative]" events.⁸¹ In 1994, when Foro started her work to promote No Kill sheltering, there was no movement to speak of. By 2001, when she held her last conference, No Kill was a powerful voice in animal sheltering that was attracting the attention of everyone in the industry.

The very name by which the movement came to be known—"No Kill"—may have been due to Foro's choice to prominently call her directories and conferences "No Kill" from the first. She did not originate the term "No Kill," as it had been in frequent use since the 1970s to apply to private shelters that did not kill healthy or treatable animals, but it may have been her use of the term in the 1990s that reframed its meaning to include the emerging concept of No Kill communities.

As the No Kill movement grew in the 1990s, the traditional shelter industry increasingly felt under attack. The potential for strained relations was perhaps greatest in communities where a municipal public shelter coexisted with a private No Kill shelter. Workers at traditional shelters felt that the not very subtle implication of the "No Kill" term was to label them as killers.⁸² Arnold Arluke, who studied the psychology of animal shelter workers, pointed out that the No Kill movement upended the world view of traditional shelter workers who "euthanized" large numbers of healthy dogs and cats.⁸³ Those workers had seen themselves as helping animals, but now the killing of healthy pets was depicted as cruel. The public began to compare traditional shelters unfavorably with No Kill shelters.

⁷⁵ Berkeley, "Doing Great Things for Animals," 31.

⁷⁶ Foro, "Know the Thrill of No Kill."

⁷⁷ Ibid.

⁷⁸ "Now Hear This," *Doing Things for Animals*, Internet Archive, <https://web.archive.org/web/20020811064311/http://www.dtf.org/pages/conf.html>.

⁷⁹ Julie Castle, "Public/Private Partnership Leads Reno to 94% Save Rate," *Best Friends Blog*, July 15, 2011, <http://blogs.bestfriends.org/index.php/2011/07/15/publicprivate-partnership-leads-reno-to-94-percent-save-rate/>; "About the Best Friends National Conference," *Best Friends Events*, Internet Archive, <https://web.archive.org/web/20160413094319/http://bestfriends.org/events/best-friends-national-conference/about>.

⁸⁰ Foro, "Know the Thrill of No Kill."

⁸¹ Clifton, "No-Kill Success and Fiscal Reality Collide."

⁸² Julie Dowling and Cynthia Stitely, "Killing Ourselves Over the Euthanasia Debate," in "The Euthanasia Debate: Deciding the Fates of Unwanted Animals," feature section, *Animal Sheltering* 20, no. 5 (1997): 4–5.

⁸³ Arnold Arluke, *Just a Dog: Understanding Animal Cruelty and Ourselves* (Philadelphia: Temple University Press, 2006), 116–119, 146.

The tension between No Kill and the traditional shelter industry in the 1990s was often called the “white hat, black hat” problem. In the view of many people in the traditional shelter industry, No Kill private shelters were picking and choosing highly adoptable animals and leaving the public shelters in the community to deal with the sick, injured, older, and otherwise less adoptable animals. The increasingly widespread opinion that No Kill shelters were morally superior to “kill” shelters added insult to injury. Traditional shelter workers also questioned the marketing approach that some No Kill shelters used, feeling that the proper function of shelter staff was animal caretaking, not selling, and that adoption marketing turned homeless animals into commodities.

In addition to the rapid growth of the No Kill movement, several other events in the 1990s brought the white-hat, black-hat controversy to a head. In 1994, the ASPCA gave up the animal control and sheltering contract for New York City, which it had held for 100 years.⁸⁴ The move was in part for financial reasons, since the ASPCA was losing money on its contract with the city, but it was also because the ASPCA no longer wanted to be identified as an animal killer.⁸⁵ Two major No Kill events in 1996, Foro’s second Doing Things for Animals conference and Richard Avanzino’s “Building a No Kill City” presentation at an AHA Leadership Conference, occurred in the face of the traditional shelter industry in Denver, where the AHA had its headquarters. And a story in the USA Today newspaper in 1997 described how the Adoption Pact in San Francisco was saving all of the city’s healthy shelter animals and many of the treatable ones.⁸⁶

In the fall of 1997, the Humane Society of the United States (HSUS), which had a long history of working closely with traditional shelters to make them more humane, devoted a feature section of its *Animal Sheltering* magazine to the white-hat, black-hat controversy.⁸⁷ This “Euthanasia Debate” issue used the term “limited admission” to refer to No Kill shelters, a characterization that HSUS personnel had introduced several months earlier at the HSUS national conference.⁸⁸ “Limited admission” shelters were contrasted with “open admission” traditional shelters, which took in all animals who came to their doors.⁸⁹ The effort to identify No Kill with limited admission, although understandable at the time since almost all No Kill shelters did limit their admissions in 1997, would lead to much confusion in the years ahead as more and more entire communities, including their open-admission shelters, became No Kill.

In 1998, HSUS took a sharper tone in its criticism of No Kill. An article in the *HSUS News* referred to the “intense national media spotlight” on shelter euthanasia policies, arguing that the debate over euthanasia was damaging the ability of humane organizations to work together to arrive at solutions.⁹⁰ The article said it was “unethical” for limited admission shelters to fundraise without acknowledging that they did not accept all animals brought to them.⁹¹ The article dismissed the success of No Kill in San Francisco as resulting from atypical demographics and resources, and noted the large amount of work and planning that the city’s No Kill program had required.⁹² This criticism seemed to assume that the amount of planning and building of resources that No Kill required could not be duplicated in other places, an assumption that was already being challenged in the Denver metro area and the state of New Hampshire.

⁸⁴ Marion Lane and Stephen Zawistowski, *Heritage of Care: The American Society for the Prevention of Cruelty to Animals* (Westport, CT: Praeger, 2008), 45–47.

⁸⁵ Jonathan Hicks, “A.S.P.C.A. Plans to Stop Killing Strays,” *New York Times*, March 26, 1993.

⁸⁶ Haya El Nasser, “Animal Shelters Going ‘No-Kill,’” *USA Today*, September 8, 1997.

⁸⁷ “The Euthanasia Debate.”

⁸⁸ Clifton, “What’s in a Name?”

⁸⁹ Dowling and Stitely, “Killing Ourselves Over the Euthanasia Debate,” 4–15.

⁹⁰ Dowling and Stitely, “Animal Shelters Debate the Role of Euthanasia,” 22.

⁹¹ *Ibid.*, 26.

⁹² *Ibid.*, 28.

Tensions between the traditional shelter establishment and No Kill continued for years, but began to abate as No Kill success stories increased. Arnold Arluke predicted the eventual reconciliation of No Kill and the traditional shelter establishment in an influential article he wrote in 2003.⁹³ This reconciliation was aided in the 2000s by traditional shelters having more time and resources per animal due to the plunge in intake numbers that occurred from 1970 to 2000. Merritt Clifton and others identified the phenomenon of falling shelter intake and publicized it. This change in circumstances meant that pet overpopulation was steadily becoming less of a barrier to finding a home for every healthy and treatable pet, thus countering the main argument against the practicality of No Kill.

In addition to growth in the number of No Kill shelters, the 1990s saw growth in the number of rescues. Rescue organizations existed before the 1990s, but they were often limited to a specific breed of dog. A directory of dog rescues published in 1989 listed hundreds of organizations dedicated to single breeds.⁹⁴ The people who ran breed-specific rescues were often hobby breeders who were motivated by a wish to keep their breed out of the hands of backyard breeders and puppy mill operators. Because hobby breeders already had a position in the market for their breed, they were able to place rescued purebreds as pets after sterilizing them to make sure they would not be used for breeding.

“All-breed” rescues, which took in mixed breeds, as well as purebreds, did not have the type of ready-made market that hobby breeders had. And before the 1990s, mixed breed dogs and cats could be hard for a small organization to place, since a person who was willing to adopt a homeless animal could probably find one on the street or in an alley near their home. As the pet overpopulation crisis abated and there were far fewer litters being born, it opened a niche for all breed rescues. The same conditions of fewer free roaming animals in the environment and falling shelter intake that allowed the idea of No Kill to flourish in the 1990s also allowed all-breed rescues to begin to find homes for substantial numbers of animals. Some all-breed rescues had brick-and-mortar shelters, but many were small, non-profit organizations staffed by volunteers who fostered animals for adoption.⁹⁵ They received homeless animals from many sources, but they often took in animals who were at risk of being killed in traditional shelters.

Petfinder, a computer database of adoptable pets launched in the mid-1990s by Betsy and Jared Saul, gave shelters and rescues a cutting-edge marketing tool.⁹⁶ The Petfinder database started with 13 shelters in New Jersey that participated by listing their adoptable animals.⁹⁷ It grew rapidly, and by the mid-2000s, Petfinder was instrumental in about 1.5 million adoptions every year.⁹⁸ Petfinder was popular because it combined wide market reach with ease of use for shelters. It was free, and the Petfinder designers made the listing and updating process as easy as possible. Adoption venues offered by PetSmart and Petco stores were another marketing opportunity for rescues and traditional shelters.⁹⁹ Their charitable offshoots, PetSmart Charities and Petco Foundation, were founded in 1994 and 1999 respectively.¹⁰⁰

⁹³ Arnold Arluke, “The No-Kill Controversy: Manifest and Latent Sources of Tension,” in *The State of the Animals II: 2003*, ed. Deborah Salem and Andrew Rowan (Washington, DC: Humane Society Press, 2003), 82.

⁹⁴ Project BREED Directory: A Nationwide Source Book for Rescue and Adoption of All Breeds of Dogs (Germantown, MD: Network for Ani-males & Females, 1989).

⁹⁵ Stephen Aronson, *Animal Control Management: A New Look at a Public Responsibility* (West Lafayette, IN: Purdue University Press, 2010), 198.

⁹⁶ Ryan Rice, “Betsy Banks-Saul,” *Life + Dog*, accessed March 27, 2017, <http://www.lifeanddog.com/betsy-banks-saul/>; Betsy Banks Saul, interview by author, April 21, 2015.

⁹⁷ Rice, “Betsy Banks-Saul.”

⁹⁸ Alex GoldFayn, “Petfinder Provides a Simpler Selection,” *Chicago Tribune*, November 19, 2005.

⁹⁹ “Pet Adoptions,” *Petco*, Internet Archive, <https://web.archive.org/web/19990417042240/http://www.petco.com/pages/adoptions.html>; “Charities, Luv A Pet,” *PetSmart*, Internet Archive, <https://web.archive.org/web/19970217024510/http://www.petsmart.com/petsmart/luvapet.htm>.

¹⁰⁰ “Leader in Pet Adoptions, Largest Funder of Animal Welfare,” *PetSmart Charities*, accessed April 30, 2017, <https://www.petsmartcharities.org/about-us>; “About Us,” *Petco Foundation*, Internet Archive, https://web.archive.org/web/20010629024803/http://www.petco.com/corpinfo_foundation.asp?.

A notable lifesaving innovation in the late 1990s was the Open Adoption concept. In January of 1999, the AHA held a forum to analyze how shelters were screening potential adopters and whether that process could be improved.¹⁰¹ The 20 participants in the forum included shelter officials and representatives of animal welfare non-profits.¹⁰² The participants looked at evidence from surveys and studies done in the 1990s on factors that caused the human-animal bond to break, resulting in relinquishment to shelters.¹⁰³ The studies showed that some factors that had been thought important in adoption screening were irrelevant—for example, pets given as gifts were not more likely to be relinquished than pets acquired by other means.¹⁰⁴ The forum participants made a list of adoption restrictions that were in common use in shelters throughout the United States. They were surprised to realize that they themselves might not qualify to adopt an animal under some of the restrictions, even though they were prominent leaders in the animal welfare profession.¹⁰⁵

One of the participants in the 1999 forum was Jan McHugh-Smith, who at that time was the executive director of the Humane Society of Boulder Valley, a large, open-admission shelter in the Denver metro area.¹⁰⁶ Her shelter started an Open Adoption program in 1997, and in 1998, adoptions increased by over 30%.¹⁰⁷ The success of this program caught the attention of national leaders and was an important factor in the decision to hold the 1999 Open Adoption forum.¹⁰⁸

The Open Adoption concept was noteworthy, not only because of the difference it made in adoption rates, but also because it was an example of the traditional shelter industry embracing a major change to its old ways of operating. The concept of Open Adoption spread rapidly among traditional shelters, a success that may have been due at least in part to the fact that it was promoted by people and institutions that had the trust of the traditional industry.

The No Kill movement received a boost in 1999 when David Duffield created Maddie's Fund from the Duffield Family Foundation.¹⁰⁹ Maddie's Fund was named after the Duffield's beloved pet Schnauzer, who had died in 1997. The fund was an early supporter of shelter medicine, which has become very important in No Kill.¹¹⁰ Maddie's Fund has also invested in model programs, collaboration among community animal welfare agencies, and promotion of transparency and accountability. Duffield endowed Maddie's Fund with \$300 million,¹¹¹ which was enough to get the attention of everyone in animal sheltering. Richard Avanzino was selected to lead the organization.

By the end of the 1990s, several communities and shelters had made No Kill resolutions. Those communities included Bozeman, Montana (1995); Austin and Travis County, Texas (1997); Otsego County,

¹⁰¹ *1999 Adoption Forum* (Englewood, CO: American Humane Association, 1999), 1, 23. The forum was sponsored by PetSmart Charities.

¹⁰² *Ibid.*, 23–24.

¹⁰³ *Ibid.*, 21.

¹⁰⁴ *Ibid.*, 3.

¹⁰⁵ *Ibid.*, 6.

¹⁰⁶ *Ibid.*, 24.

¹⁰⁷ ASPCA and PetSmart Charities, *Humane Society of Boulder Valley: Pioneers in Open Adoptions* (2007), 2.

¹⁰⁸ *Ibid.*, 3.

¹⁰⁹ "A Schnauzer's Legacy," *All Animals*, May-June 2014.

¹¹⁰ Richard Avanzino, interview by author, April 30, 2015.

¹¹¹ "A Schnauzer's Legacy," *All Animals*.

Michigan (1999); Hailey, Idaho (1999); and Tompkins County, New York (1999).¹¹² In the late 1990s, Los Angeles, Las Vegas, and San Diego County all set No Kill goals.¹¹³

The year 2000 marked the end of an era for animal sheltering. The period from 1970 to 2000 had been a time of immense change in fundamental trends affecting the animal shelter industry. Sterilization rates for owned cats and dogs soared, shelter intake plunged, public attitudes toward pets improved, TNR for feral cats became popular, the animal rights movement gained attention, progressive shelters developed new operating procedures and models, and the grassroots No Kill movement matured. By the year 2000, the stage was set for rapid change in the traditional shelter industry. The progress of the No Kill movement after 2000 deserves its own book, but the Epilogue takes a brief look at nationwide lifesaving trends from 2000 to 2018.

¹¹² Austin and Travis County No Kill Resolutions, accessed March 27, 2017, <http://nokillnow.com/nokillresolutions.htm#Austin>; Otsego County Resolution No. 1999–31, May 11, 1999, accessed April 30, 2017, <http://www.otsegocountymi.gov/wp-content/uploads/2015/12/OCR-1999-31-No-Kill-Policy.pdf>; “The First No-Kill Shelter In Idaho,” *Animal Shelter of the Wood River Valley*, accessed March 27, 2017, <http://animalshelterwrv.org/about/>; “History of the SPCA,” *SPCA of Tompkins County*, accessed October 22, 2014, <http://spcaonline.com/index.php/about-us/history>; Bonney Brown, private collection.

¹¹³ Bonney Brown, private collection.

Epilogue: No Kill in the 21st Century

This book tells the story of how animal sheltering in the United States developed up to the year 2000, including the origin of the No Kill movement. I said in the Introduction that the No Kill era of animal sheltering began around the year 2000. This epilogue outlines the basis for that conclusion.

Annual shelter intake in the United States in the year 2000 is thought to have been about seven million, down from perhaps as many as 22 million in 1970. As shelter intake was plunging in the years from 1970 to 2000, the human population was growing. The sharply reduced level of shelter intake and the increase in the number of available homes for pets meant that by the year 2000 No Kill was no longer a crazy idea. What had seemed visionary or impossible in the 20th century—finding a home for every homeless cat or dog—suddenly seemed much more practical. In the early 2000s, organizations were formed in Atlanta, New York City, Jacksonville, and many other cities and counties to spearhead change in their municipal shelters. As this Epilogue is being written in 2018, the Best Friends Animal Society has announced a goal for the entire United States to be No Kill by 2025.

Although many of the basic programs and models that underpin No Kill were developed in the years from 1970 to 2000, No Kill has continued to create new programs since then and expand on old programs. In recent years, these initiatives have streamlined the process of getting to No Kill and have allowed shelters to reach very high live release rates.

One of the most influential of the new programs is “managed admission.” Managed admission means asking people who want to surrender a pet to the shelter in a non-emergency situation to make an appointment. In a traditional shelter, an animal could be dropped off at any time, with no notice. It was difficult to plan for staffing needs under those circumstances because the operations manager could not predict how many animals were going to be surrendered on any given day. That resulted in inefficiency and worker stress. One benefit of managed admission is to change peaks and valleys in intake to a more predictable flow by having a set number of appointments each day.

Another benefit of managed admission is that during the appointment, a shelter worker or volunteer can talk with the owner to determine whether surrender can be avoided. If a behavior issue, veterinary expenses, or a problem finding pet-friendly housing is the reason for surrender, the shelter may be able to keep the pet in the home by providing help to fix the problem. If not, intake counselors may still be able to keep the pet out of the shelter by asking people if they are willing to “foster” their pet while working with the shelter to place it directly with a rescue or a new adoptive home. This is less stressful for the pet than being taken into the shelter.

Another recent No Kill initiative that can sharply reduce shelter intake is the “community cat” approach to outdoor cats. Studies have indicated that lost cats are far more likely to return home if they are left where they are than if they are taken into a shelter.¹ And healthy unowned cats generally have territories where they have shelter and food sources. In a community-cat program, cats with no identification who are found outdoors are given a health check and the healthy ones are vaccinated, sterilized, and returned to the place where they were found. Shelters that use this “return to field” process have more time and resources to take care of owner-surrendered, sick, and injured cats. The community-cat approach has garnered wide support and appears well on its way to becoming the dominant paradigm in cat management.

Shelter medicine has played an important part in increasing the number of live releases in recent years. Shelter medicine was recognized as a specialty by the American Veterinary Medical Association in 2014, just 15 years after the first formal class in shelter medicine was held. In that short time, shelter medicine has influenced every aspect of sheltering, from design of a new generation of shelter buildings to improving

¹ See chapter 14.

shelter flow-through to controlling communicable disease to sterilizing all animals before adoption to implementing community-cat programs.

Other important programs have been developed in recent years to address specific problems. One example is Dogs Playing for Life, which uses dog playgroups at shelters to help ward off kennel stress. Another example is a program called Pets for Life that was developed by the Humane Society of the United States to help underserved neighborhoods.

Some older programs have branched off in new directions. Fostering is one example, as it is increasingly being used as a first-line program for high energy dogs and neonatal kittens. Transport has grown dramatically, and today tens of thousands of animals are moved each year, in most cases going from high-intake southern shelters to shelters and rescues in the north. Mega adoption events have been around since the 1990s, but in recent years, they have increasingly become regional and even national events that are designed to make shelter participation easy. The importance of No Kill consulting, mentoring, and apprenticeships has grown, as the movement has increasingly realized that a personal connection may be the fastest way to jump-start a No Kill effort.

An interesting historical question is whether shelters nationwide in the years before 2000 could have used No Kill techniques to save all their healthy and treatable animals. We know that shelter intake per thousand people was several times higher in the early 1970s than it is today.² The number of homeless animals in the environment, including litters of puppies and kittens born to the large number of unsterilized, owned animals, was also high before the spay-neuter campaigns of the period from 1970 to 2000 took effect. Even if we focus just on the number of animals killed in shelters in 1970, and ignore the many homeless animals in the environment who did not come into shelters, it seems unlikely that No Kill could have been possible in most communities at that time.

The number of owned pets in 1970 is estimated to have been about 60 million.³ The number of cats and dogs killed in shelters that year is unknown, but is thought to have been in the ballpark of 20 million, with shelter intake at roughly 22 million. In 2018, by contrast, the estimate of owned pets is roughly 175 million, with an estimated six to eight million cats and dogs entering shelters each year. The number euthanized in 2017 may have been as low as 1.5 million according to estimates.

Even with much lower intake, the excellent public shelters of today must work hard to achieve their very high live release rates. If they had three times as many animals and only one-third as many potential homes (typical 1970 conditions), it is difficult to imagine that they could save all their healthy and treatable animals. Some people have promoted the idea that shelters could have just refused to take in animals who could not be placed in new homes. As discussed in chapter 8, however, this might not have been an approach that the public would have tolerated in the 20th century due to public health and nuisance concerns. It may be that the No Kill era of animal sheltering started when it did, around the year 2000, because conditions would not have allowed it to start earlier.

Perhaps the biggest single difference between shelters in the current No Kill era and shelters in the 20th century is in their attitude toward the public. One job of a No Kill shelter is to brand the animal shelter as the place to go to get a pet. In the No Kill era, shelters hold crowd-pleasing events like First Nights and Yoga with Cats that include an opportunity to adopt a pet. When communities today build new shelters with

² See chapter 10.

³ Paul Irwin, "Overview: The State of Animals in 2001," in *The State of the Animals: 2001*, ed. Deborah Salem and Andrew Rowan (Washington, DC: Humane Society Press, 2001), 2.

No Kill in mind, they locate the buildings in areas with a lot of foot traffic. Animal shelters in the 20th century, by contrast, were often lowly concrete block buildings located in an out-of-the-way spot near the landfill.

The animal care and control system are increasingly becoming an important factor in how people evaluate whether a city is a good place to live. Today, with pets commonly seen as family members, citizens are demanding that cities and counties offer a comprehensive safety net for pets. This concept of shelter services as a lifesaving safety net for all pets, owned or unowned, is one of the things that distinguishes the No Kill era of sheltering from previous eras.

A question for the future is whether we will soon be facing a shelter pet shortage. In recent years, volunteers have transported large numbers of dogs and a smaller number of cats from areas of low demand to areas of high demand within the United States. If current trends continue, we may come to a time in the not-too-distant future when interstate transports will not be able to provide shelters in high demand areas with enough animals to meet adoption demand. Some shelters and rescues in the United States have imported homeless animals from other countries for humanitarian reasons. Such imports require oversight to make sure that diseases like rabies are not imported along with the animals, but hundreds of thousands of pets (mostly dogs) are already successfully and safely imported into the United States each year, many of them for commercial sale. It might be that an expansion of humanitarian imports of homeless animals from other countries could help avert a future shortage of shelter pets in the United States. If shelters are not able to supply the pet market in the future it could lead to a resurgence in commercial breeding, with all the animal welfare concerns that would entail.

In 1987, Edward Duvin, the first philosopher of No Kill, wrote that “we must transform dreary shelters from death camps into vibrant community resource centers—where the public can observe that shelters are not stagnant buildings whose primary function is to kill, but dynamic learning centers where individual suffering is compassionately addressed within a larger context of reverence for all life.”⁴ Many people thought Duvin’s vision would never be realized, but today it has been achieved in a rapidly growing number of communities. It appears to be only a matter of time before it is achieved nationwide.

⁴ Edward Duvin, “Status Quo Blues,” *animalines* 4, no. 1 (December 1987).